

860 Tapping Machine

Tapping Sizes: 4- to 20-inches

Model 860C



T.D. Williamson

Bulletin No: **1000.008.10**

Version: 02.2025

Supersedes: 1000.008.09 (08.2022)



Description

Tapping machines are used for making connections to pipelines, tanks, and plant piping without shutdown and to make hot taps in preparation for plugging machine application.

The 860 Tapping Machine is hydraulically operated and is used for making pipe and tank taps from 4- to 20-inch (DN80 to DN500). It includes an electric start, diesel power unit. Its maximum working pressure is 1,480 psi (100 bar) at 100° F (38° C). Its operating temperature is -20° F (-9° C) to 700° F (371° C) at 700 psi (48 bar) for intermittent service. Its maximum continuous rating is 350° F (177° C) at 1,025 psi (70 bar).

This model features a split frame for lower maintenance costs and ease of packing replacement. The tapping machine power unit is compliant with EPA Tier 4 emission standards, has an emergency air shut-off valve and a four point lift system.

Features

The basic machine includes:

- "Lower-in" crank
- Measuring rod
- Retainer rod pusher
- Ring gasket
- Bleeder valve and nipple
- Motor adapter
- Set of bolts and nuts
- LOCK-O-RING® bypass gauge
- Convenient storage on dedicated skid
- Speed control without changing power unit RPM
- Pendant Control System (50 ft.)

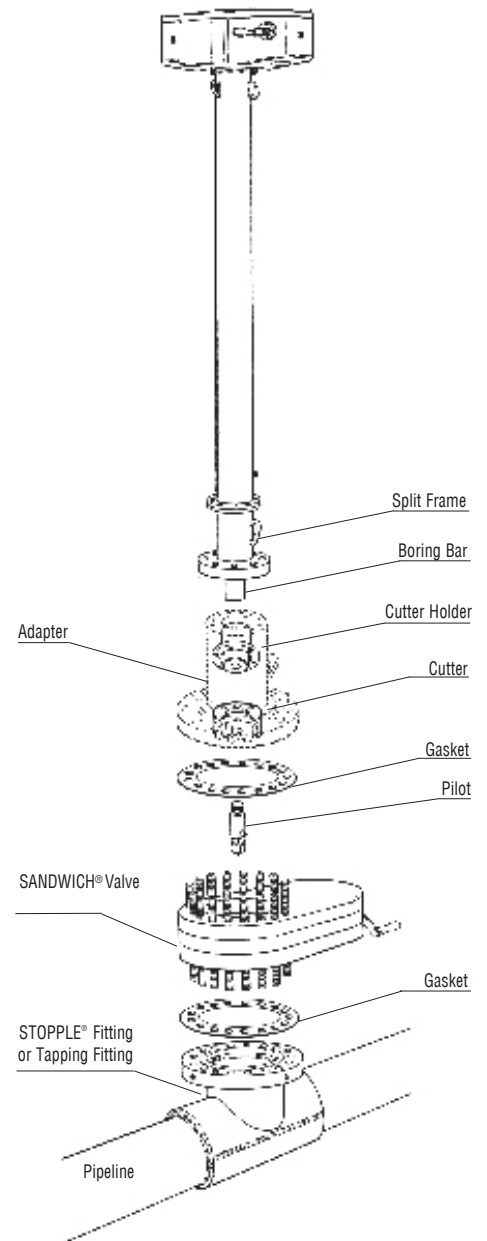



860 Tapping Machine *Model 860c*

Operating Specifications	Standard Feed (.003-in./Revolution)	Alternate Feed (.005-in./Revolution)
Boring Bar Travel	66-inches (1,676 mm)	66-inches (1,676 mm)
Tank Taps*	4- through 12-inch (80-300 mm)	4- through 12-inch (80-300 mm)
Pipe Taps*	4- through 20-inch (80-500 mm)	4- through 20-inch (80-500 mm)
Max. Operating Pressure	1,480 psi (100 bar) at 100° F (38° C)	1,480 psi (100 bar) at 100° F (38° C)
Max. Operating Temperature	700° F (371° C) at 700 psi (48 bar)**	700° F (371° C) at 700 psi (48 bar)**
Power	Hydraulic	Hydraulic
Feed Rate	.003-inch (.076 mm) per revolution	.005-inch (.127 mm) per revolution
“Lower-In” Crank	7-1/2 turns per inch (3.4 mm per turn)	4-1/2 turns per inch (5.6 mm per turn)
Length without measuring rod	88-1/2-inches (2,248 mm)	88-1/2-inches (2,248 mm)
Length with measuring rod	158-1/2-inches (4,026 mm)	158-1/2-inches (4,026 mm)
Meets NACE specification	MR0175-2000	MR0175-2000

* See note 5 in “Recommended Power Options” Chart.

** For intermittent service only. Its maximum continuous rating is 350° F (177° C) at 1,025 psi (70 bar).

Hydraulic Operation Model (Std)	Standard Feed (.003-in./Revolution)			Alternate Feed (.005-in./Revolution)		
	Lb.	Kg.	Part Number	Lb.	Kg.	Part Number
Tapping Machine w/ Hydraulic Drive	750	340	12391884	750	340	12366996
Tapping Machine w/ Skid	1025	465	12391885	1025	465	12366999
Skid	275	125	12359746	275	125	12359746
Hydraulic Power Unit*	1650	750	12359275	1650	750	12359275

* Includes Hydraulic Piping Hoses

Power Unit

Engine: Diesel	38 HP @ 2800 RPM
Pump	Piston Type/Vane
Hydraulic Reservoir Capacity	55 Gallons
Engine Fuel Capacity (Diesel Engine)	10.5 Gallons
Hydraulic Oil Filters	Micron
Motors (at tapping machine)	Gear Type
Battery 12-volt, 455 amp, cold crank at 0°F	Customer Provided

860 Tapping Machine *Model 860c*

Standard Universal Adapters for SANDWICH® Valves and Ball Valves

(Capable of Setting LOCK-O-RING® and LOCK-O-RING® Plus Completion Plug)

		ASME Class 300 RF Flange			ASME Class 600 RF Flange		
Inches	mm	Lb.	Kg.	Part Number	Lb.	Kg.	Part Number
4	100	75	34	26-3205-0430	85	39	26-3205-0460
6	150	100	45	26-3205-0630	130	59	26-3205-0660
8	200	125	57	26-3205-0830	170	77	26-3205-0860
10	250	210	95	26-3205-1030	285	129	26-3205-1060
12	300	300	136	26-3205-1230	375	170	26-3205-1260
14	350	350	159	26-3205-1430	425	193	26-3205-1460
16	400	490	222	26-3205-1630	610	277	26-3205-1660
18	450	690	299	26-3205-1830	800	363	26-3205-1860
20	500	850	386	26-3205-2030	1025	465	26-3205-2060

Special Shortened Adapters for Gate Valves

		ASME Class 150 RF Flange			ASME Class 300 RF Flange			ASME Class 600 RF Flange		
Inches	mm	Lb.	Kg.	Part Number	Lb.	Kg.	Part Number	Lb.	Kg.	Part Number
4	100	57	26	06-6102-0004*	65	29	06-6103-0004	80	36	06-5091-0004
6	150	70	32	06-5088-0006*	95	43	06-6103-0006	146	66	06-5091-0006
8	200	85	39	06-6102-0008*	100	45	06-6103-0008	150	68	06-6105-0008
10	250	115	42	06-6102-0010*	155	70	06-6103-0010	200	91	06-6105-0010
12	300	170	77	06-6102-0012*	215	98	06-6103-0012	315	143	06-6105-0012
14	350	191	87	06-6102-0014	227	103	06-6103-0014	359	163	06-6105-0014
16	400	300	136	06-6102-0016	350	160	06-6103-0016	460	210	06-6105-0016

* Will work on SHORTCUTT® Valves, Bulletin 2010.000.00

Consult the factory for 18 in. and 20 in. adapterrs.

Cutter Holders & LOCK-O-RING® Plug Holders

		Cutter Holders			LOCK-O-RING® Plug Holders		
Inches	mm	Lb.	Kg.	Part Number	Lb.	Kg.	Part Number
4	100	2.5	1	05-1168-0000	3.5	2	05-0075-0000
6-12	150-300	9	4	05-1167-0000	3.5	2	05-0075-0000
14-20	350-400	16	7	05-1166-0000	10	4.5	05-1044-0000

LOCK-O-RING® Plus Plug Holders

		Cutter Holders			LOCK-O-RING® Plus Plug Holders		
Inches	mm	Lb.	Kg.	Part Number	Lb.	Kg.	Part Number
4-6	100-150	2.5	1	05-1168-0000	3.5	2	12373178
8-20	200-500	9	4	05-1167-0000	10	4.5	12354463

■ Splined Drive Feature

The new splined drive provides much greater strength to the end of the boring bar, as it turns the cutter.

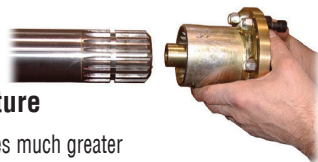

■ Split Frame Feature

The frame assembly is split at the lower end, so that the lower section can be unbolted and removed over the drive tube and boring bar and the packing replaced.

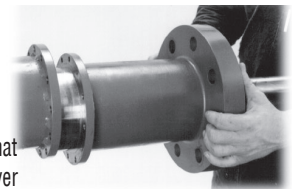



T.D. Williamson

1000.008 - p4

Dimensions and Part Numbers

860 Tapping Machine *Model 860c*

Standard Cutters & Pilot Drills

Nominal Tap Size		Actual Size		Cutters			Pilot Drills			Spare U-Rods
Inches	mm	Inches	mm	Wt./Lb.	Wt./Kg.	Part Number	Wt./Lb.	Wt./Kg.	Part Number	Part Number
4	100	3-7/16	87.3	2	0.9	05-0328-0004	1/2	0.2	05-0293-0008	00-1424-0012
6	150	5-15/32	138.9	5-3/4	3	05-0328-0006	2	0.9	05-0293-0002	00-1424-0003
8	200	7-5/16	185.8	14-1/2	7	05-0328-0008	2	0.9	05-0293-0003	00-1424-0003
10	250	9-1/2	241.3	22-1/2	10	05-0328-0010	2	0.9	05-0293-0004	00-1424-0003
12	300	11-1/2	292.1	36	16	05-0389-0012	2-1/2	1.0	05-0293-0005	00-1424-0008
14	350	12-3/4	323.9	42	19	05-0389-0014	5-1/2	2.5	05-0294-0002	00-1424-0008
16	400	14-11/16	373.1	61	28	05-0389-0016	6	2.7	05-0294-0003	00-1424-0008
18	450	15-1/16	383	53-1/2	24	05-0388-0016	6	2.7	05-0294-0003	00-1424-0008
20	500	17	432	84	38	05-0388-0018	6-1/2	3	05-0294-0004	00-1424-0008

SHORTSTOPP® Cutters & Pilot Drills

4	100	3-7/8	98.4	3-1/4	1	05-0330-0004	1/2	0.2	05-0293-0008	00-1424-0012
6	150	5-7/8	149.2	8-3/4	3	05-0330-0006	2	0.9	05-0293-0002	00-1424-0003
8	200	7-3/4	196.9	20	9	05-0330-0008	2	0.9	05-0293-0003	00-1424-0003
10	250	9-3/4	247.7	23	10	05-0330-0010	2	0.9	05-0293-0004	00-1424-0003
12	300	11-3/4	298.5	40	18	05-0330-0012	2-1/2	1.0	05-0293-0005	00-1424-0003

STOPPLE® Cutters & Pilot Drills

4	100	3-15/16	100	3-1/2	2	05-0329-0004	1/2	0.2	05-0293-0008	00-1424-0012
6	150	5-15/16	150.8	9	4	05-0329-0006	2	0.9	05-0293-0002	00-1424-0003
8	200	7-7/8	200	16	7	05-0329-0008	2	.09	05-0293-0003	00-1424-0003
10	250	9-7/8	200.8	27	12	05-0329-0010	2	0.9	05-0293-0004	00-1424-0003
12	300	11-13/16	300.1	40-1/2	18	05-0388-0012	2-1/2	1	05-0293-0005	00-1424-0008
14	350	13-1/16	331.8	49	22	05-0388-0014	5-1/2	2.5	05-0294-0002	00-1424-0008
16	400	15-1/16	382.6	64	29	05-0388-0016	6	2.7	05-0294-0003	00-1424-0008
18	450	17	432	84	38	05-0388-0018	6-1/2	3	05-0294-0004	00-1424-0008
20	500	19	483	98	45	05-0388-0020	7-1/2	3	05-0294-0005	00-1424-0008



860 Tapping Machine *Model 860c*

Recommended Power Options for Tapping Size On Size

Feed Rate (0.005 in./REV) HYD	Cutter Size (in.)								
	4	6	8	10	12	14	16	18	20
	A	A	A	A	A	A	A	A	A
	B	B	B	B	B	B	B	B	B
	C	C	C	C	C	C			

Notes

- The following letters represent:
 A = Carbon steel pipe SMYS (Specified Minimum Yield Strength) 30,000 to 50,000 psi, maximum tensile strength of 70,000 psi.
 B = Carbon steel pipe SMYS 50,000 to 70,000 psi, maximum tensile strength of 90,000 psi.
 C = Cast iron pipe. Cutting characteristics vary widely; hard to predict.
- The table (above) is based on the latest TDW designs and past experience. The data should be used as a guideline. There have been, and will be, conditions which will not strictly follow the guidelines.
- Special pipeline material, such as chrome-moly, or 300 stainless steel, will require special equipment and procedures. Contact TDW representative for recommendations.
- When tapping a larger pipe or tank, the cutter will sometimes go through the flat-plate condition. For example, all teeth are cutting at the same time. This is the most power-consuming condition possible and special cutters may be required. Considering cutter size, diameter of cylinder, wall thickness, different materials of construction, etc., the possibilities are infinite. The following table gives some examples of flat-plate conditions. Any pipe or tank with wall thicknesses greater than those shown will also be considered flat plate.

Cutter Size (in.)	Nom. Pipe x Wall	Nom. Pipe x Wall	Nom. Pipe x Wall
4	6" x .481"	8" x .357"	10" x .282"
6	10" x .748"	12" x .616"	14" x .556"
8	18" x .776"	20" x .692"	24" x .571"
10	24" x .980"	30" x .772"	48" x .475"
12	36" x .943"	48" x .699"	60" x .556"
14	48" x .862"	60" x .685"	72" x .569"
16	56" x .980"	60" x .913"	72" x .757"

Dimensions and Part Numbers

860 Tapping Machine *Model 860c*



T.D. Williamson

1000.008 - p6