

936f Tapping Machine

Sizes: 12- to 42-inch

Model 936f, Completion plug setting sizes 12- to 42-inches



T.D. Williamson

Bulletin No: 1000.009.09

Version: 08.2024

Supersedes: 1000.009.08 (03.2024)

Description

Tapping machines are used for making connections to pipelines, tanks, and plant piping without shutdown and are used to make hot taps in preparation for plugging machine applications.

The 936 Tapping Machine is hydraulically operated and is used for making pipe and tank taps from 12- to 36-inch, with 42-inch under certain conditions. Its operating temperature is 0°F (-18°C) to 180°F (82°C) at 2,220 psi (153 bar). For temperatures above 180°F (82°C), consult the factory.

The 936 Tapping Machine's unique pressure balanced system eliminates the effects of pipeline pressure, reducing operating loads on the feedscrew.

The 936 Tapping Machine meets NACE standard MR0175 (sulfide stress cracking resistant metallic material for oilfield equipment). The Tapping Machine Power Unit is compliant with EPA Tier 4 emission standards, has an emergency air shut-off valve and a four point lift system.

Features

The basic machine includes:

- Tapping machine
- Ladder and platform
- Hydraulic piping
- Skid
- Connecting hoses
- Power unit
- 2-Stage drive motors
- Feed motor
- Pressure-balance system

Consult the factory for special cutters and pilots required for tank taps.

Typical Tapping Setup

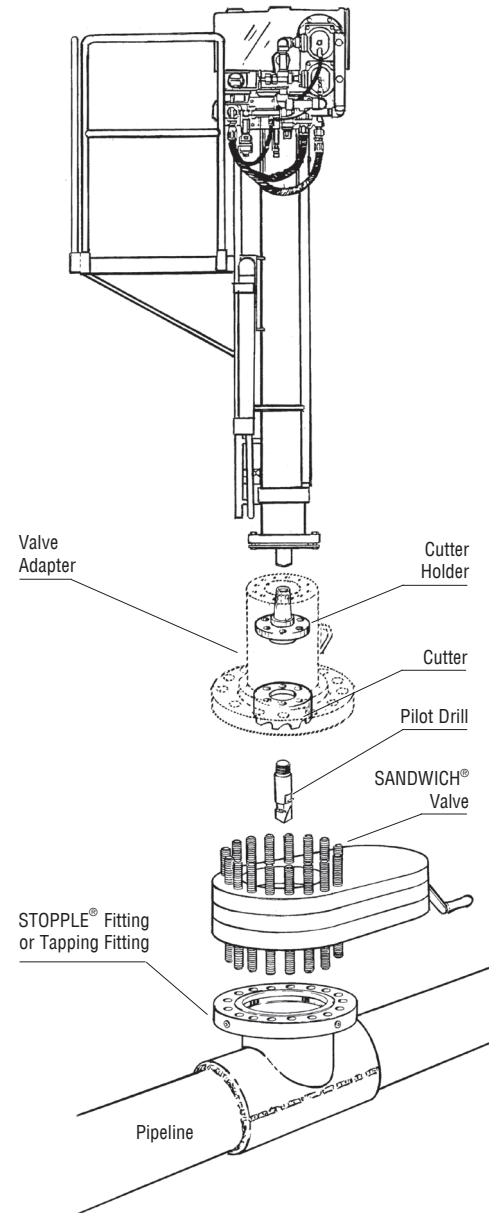



936 Tapping Machine *Model 936f*

	936f			936f- XXL		
	Lb.	Kg.	Part Number	Lb.	Kg.	Part Number
Complete System *:	4652	1815	05-1286-0000	5100	2313	12367000
Tapping Machine	2000	910	05-1286-0001	2300	1043	12366998
Ladder and Platform	255	115	05-1330-0000	300	136	05-1331-0000
Hydraulic Piping	257	116	00-1297-0000	300	136	00-1328-0000
Skid	400	180	12376647	500	227	12376000
Power Unit with Diesel Engine**	1650	750	1234757 (fixed)	1650	750	12382387(variable)

* Tapping Machine, ladder, platform and hydraulic piping included in Complete System 05-1286-0000

** Battery not included. Connecting Hoses Included.

Lengths	Boring Bar Travel		Machine		Machine with Measuring Rod	
	Inches	mm	Inches	mm	Inches	mm
936f	106	2692	146	3718	229	5817
936f-XXL	128	3251	178	4521	318	8077

Operating Specifications

Maximum Operating Pressure	2,220 psi (153 bar) @ 180°F (38°C)
Power	Hydraulically Powered
Feed	0.004" (0.102 mm) per Revolution
Lower-In Crank	12 Turns per Inch (2.1 mm/turn)

Power Unit

Engine: Perkins Diesel	38 HP @ 2800 RPM
Pump	Fixed or Variable Displacement
Hydraulic Reservoir Capacity	60 Gallons
Engine Fuel Capacity (Diesel Engine)	10.5 Gallons
Hydraulic Oil Filters	10 Micron
Motors (at tapping machine)	Gear Type
Battery 12-volt, 455 amp, cold crank at 0°F	Customer Provided

* Use Fixed for sizes 12-24" (PN 12354757), Use Variable for sizes 30-42" (PN 12382387)



936 Tapping Machine *Model 936F*

Adapters for Standard Valves

Nominal Tap Size		ASME Class 150 RF Flange*			ASME Class 300 RF Flange*			ASME Class 600 RF Flange*			ASME Class 900 RTJ		
Inches	DN	Lb.	Kg.	Part Number	Lb.	Kg.	Part Number	Lb.	Kg.	Part Number	Lb.	Kg.	Part Number
12	300	170	77	06-5184-0012	255	116	06-5085-0012	268	122	06-5185-0012			
14	350	240	109	06-5184-0014	232	105	06-6106-0014	354	161	06-5185-0014	610	277	26-2184-0014
16	400	280	127	06-5184-0016	315	143	06-6106-0016	510	231	06-5185-0016	820	373	26-2184-0016
18	450	329	149	06-5184-0018	363	165	06-6106-0018	560	254	06-5185-0018			
20	500	425	193	06-5184-0020	465	211	06-6106-0020	730	331	06-5185-0020	1,550	705	26-2109-2090
22	550	416	189	06-5184-0022	567	257	06-6106-0022	925	420	06-5185-0022			
24	600	612	278	06-5184-0024	786	357	06-6106-0024	1,125	510	06-5185-0024	2,770	1,227	26-2252-2490
26	650	633	287	06-5184-0026	920	417	06-6106-0026	960	435	06-5185-0026	3,100	1,410	26-2109-2690
28	700	700	318	06-5184-0028	1,066	484	06-6106-0028	1,530	694	06-5185-0028			
30	750	791	359	06-5184-0030	1,375	624	06-6106-0030	1,875	851	06-5185-0030	3,650	1,750	26-2184-0030
32	800	990	449	06-5184-0032	1,580	720	06-6106-0032	2,036	924	06-5185-0032			
36	900	1,650	748	06-5184-0036	2,650	1,200	06-6106-0036	2,615	1,186	06-5185-0036	6,400	2,910	26-2184-0036
38	950							4,064	1,856	06-5087-0038			
40	1000							5,042	2,287	06-5087-0040			
42	1050	2,870	1,305	06-5184-0042				5,736	2,601	06-5087-0042			

* Use with Class 900 to 600 Spool Adapter (06-9524-0000)

Adapters for TDW SANDWICH® Valves

Nominal Tap Size		ASME Class 600 RF Flange*			ASME Class 900 RTJ**		
Inches	DN	Lb.	Kg.	Part Number	Lb.	Kg.	Part Number
12	300	234	106	06-5087-0012	620	282	26-2184-0012
14	350	440	200	06-5087-0014	740	336	26-2184-0014
16	400	614	279	06-5087-0016	820	372	26-2184-0016
18	450	687	312	06-5087-0018			
20	500	1,148	521	06-5087-0020			
22	550	1,400	635	06-5087-0022			
24	600	1,750	794	06-5087-0024			
26	650	2,011	912	06-5087-0026			
28	700	2,380	1,080	06-5087-0028			
30	750	2,573	1,167	06-5087-0030	3850	1746	26-2184-0030
32	800	3,180	1,442	06-5087-0032			
34	850	3,550	1,610	06-5087-0034			
36	900	4,050	1,837	06-5087-0036	6400	2902	26-2184-0034
38	950	4,064	2,032	06-5087-0038			
40	1000	5,050	2,292	06-5087-0040			
42	1050	5,750	2,615	06-5087-0042			

* Use with Class 900 to 600 Spool Adapter (06-9524-0000)

** Other sizes available upon request.



936 Tapping Machine *Model 936F*

Standard Hot Tap Applications

Nominal Tap Size		Actual Size		Standard Cutters			Standard Pilot Drills			Spare U-Rods	
Inches	DN	Inches	mm	Lb.	Kg.	Part Number	Lb.	Kg.	Part Number	Part Number	Qty.
12	300	11-1/2	292	36	16	05-0389-0012	22	10	05-0502-0004	00-1424-0020	8
14	350	12-3/4	324	42	19	05-0389-0014	22	10	05-0502-0004	00-1424-0020	8
16	400	14-11/16	373	55	25	05-0389-0016	25	11	05-0502-0003	00-1424-0020	6
18	450	15-1/16	383	53-1/2	24	05-0388-0016	25	11	05-2418-0005	00-1424-0020	6
20	500	17	432		84	38	05-0388-0018	25	11	05-2418-0005	00-1424-0020
22	550	19	483	98	45	05-0388-0020	25	11	05-2418-0005	00-1424-0020	6
24	600	21	533	125	57	05-0388-0022	26	12	05-2418-0001	00-1424-0020	8
26	650	23	584	126	57	05-0388-0024	26	12	05-2418-0001	00-1424-0020	8
28	700	25	635	156	71	05-0388-0026	28	13	05-2418-0003	00-1424-0020	10
30	750	27	686	232	105	05-0388-0028	28	13	05-2418-0003	00-1424-0020	10
32	800	29	737	275	125	05-0388-0030	28	13	05-2418-0003	00-1424-0020	10
34	850	31	787	230	150	05-0388-0032	29	13	05-2418-0006	00-1424-0020	12
36	900	33	838	395	179	05-0388-0034	29	13	05-2418-0006	00-1424-0020	12
38	950										
40	1000										
42	1050										

STOPPLE® Applications

Nominal Tap Size		Actual Size		STOPPLE® Cutters			STOPPLE® Pilot Drills			Spare U-Rods	
Inches	DN	Inches	mm	Lb.	Kg.	Part Number	Lb.	Kg.	Part Number	Part Number	Qty.
12	300	11-13/16	300	40-1/2	18	05-0388-0012	22	10	05-0502-0004	00-1424-0020	8
14	350	13-1/16	332	49	22	05-0388-0014	22	10	05-0502-0004	00-1424-0020	8
16	400	15-1/16	383	53-1/2	24	05-0388-0016	25	11	05-0502-0003	00-1424-0020	6
18	450	17	432	84	38	05-0388-0018	25	11	05-2418-0005	00-1424-0020	6
20	500	19	483	98	45	05-0388-0020	25	11	05-2418-0005	00-1424-0020	6
22	550	21	533	125	57	05-0388-0022	25	11	05-2418-0005	00-1424-0020	6
24	600	23	584	126	57	05-0388-0024	26	12	05-2418-0001	00-1424-0020	8
26	650	25	635	156	71	05-0388-0026	27	12	05-2418-0002	00-1424-0020	10
28	700	27	686	232	105	05-0388-0028	28	13	05-2418-0003	00-1424-0020	10
30	750	29	737	275	125	05-0388-0030	28	13	05-2418-0003	00-1424-0020	10
32	800	31	787	330	150	05-0388-0032	28	13	05-2418-0003	00-1424-0020	10
34	850	33	838	395	179	05-0388-0034	29	13	05-2418-0006	00-1424-0020	12
36	900	35	889	430	195	05-0388-0036	30	14	05-2418-0004	00-1424-0020	12
38	950										
40	1000										
42	1050										



936 Tapping Machine *Model 936F*

LOCK-O-RING® Plug Holder	Inches	Size		Weight		Part Number
		DN		Lb.	Kg.	
	12-36	300-900		14	6.4	05-0076-0000

Cutter Holders

	12-42	300-1050		40	18.2	05-1287-0000
--	-------	----------	--	----	------	--------------

LOCK-O-RING® Bypass Gauge

				8 oz.	227 grams	07-0963-0000
--	--	--	--	-------	-----------	--------------

LOCK-O-RING® Plus Plug Holder	Inches	Size		Weight		Part Number
		DN		Lb.	Kg.	
	12-20	300-510		42	19	12308080
	22-36	560-900		19	8.6	12396965*
	38-42	965-1067		25	11	XXX

*Requires 05-1287-0000 to operate.