

3-WAY THREAD-O-RING™ Fittings

ASME B31.3 / B31.4 / B31.8 / CSA Z662 CAT I

Sizes: 1, 1.25, and 2-inches



T.D. Williamson

Bulletin No: 2100.027.02

Version: 02.2024

Supersedes: 2100.027.02 (01.2024)



■ Temporary Isolation Plug

■ 3-WAY THREAD-O-RING™ Fitting

Description

TDW's new 3-WAY™ Thread-O-Ring Fittings (TOR) serve as an ideal solution for branching, typically off larger main lines.

These fittings are designed for hot tap tie-ins of lateral taps and cross over connections, eliminating the need to leave a valve on the connection. Common applications include farm taps, customer service lines, gauge points, regulator sense lines, and fuel gas lines.

3-WAY™ TOR fittings are available in three sizes: 1, 1.25, and 2-inch (DN25, DN32, and DN50).

These fittings meet ASME B31.3/B31.4/B31.8/CSA Z662 CAT I for use in piping, pipeline transportation, and gathering systems for liquid, gas hydrocarbons and other fluids, as well as refining locations.

The 3-WAY T-O-R Fitting has a maximum operating pressure of 1480 psi (102 bar) and a design temperature at -20°F to 250°F (-29°C to | 121° C).

Features

The complete 3-WAY THREAD-O-RING Fitting consists of a fitting body, completion cap, and a T-O-R plug.

3-WAY THREAD-O-RING Fitting can be tapped without shutdown using TDW Drilling Machines. Fitting outlet allows for socket or butt welding connection to the 3-WAY Tee.

A temporary isolation plug is also available to block flow through the outlet of the fitting. This plug can be set using standard TDW equipment, such as a T-101, TD-112, and a Shortcut[®] Valve.

If tapping a 1- or 1.25-inch fitting using the 2-inch SHORTCUTT 500 Valve (PN 09-0758-0000-00), a 2x1.5-inch hex-head bushing (PN 00-0644-0015-00) is required to install the valve onto the fitting.

Fittings and associated products are shipped rapidly to meet customer needs. Contact your local TDW representative for pricing and availability.



3-WAY THREAD-O-RING™ Fittings

Size

Inches	DN	Part Number
1	25	12390989
1.25	32	12390990
2	50	12391385

Minimum Required Pipeline Wall Thickness† (in inches) For Listed Design Factor (DF) and Maximum Working Pressure (in psi)														
Per ASME B31.4, ASME B31.8 and CSA Z662 CAT I at -20°F to 250°F													Per ASME B31.3 at -20°F to 250°F	
12390989 1in BRANCH CONNECTION	Nominal Pipeline Size	Pipe OD (in)	0.72 DF	Pressure	0.6 DF	Pressure	0.5 DF	Pressure	0.4 DF	Pressure	0.2 DF	Pressure		
	1.25	1.66	0.049	1480	0.059	1480	0.073	1480	0.094	1480	0.134	980	0.066	1480
	1.5	1.9	0.056	1480	0.068	1480	0.083	1480	0.108	1480	0.153	980	0.075	1480
	2	2.375	0.070	1480	0.084	1480	0.104	1480	0.135	1480	0.191	980	0.093	1480
	2.5	2.875	0.085	1480	0.102	1480	0.126	1480	0.163	1480	0.240	980	0.112	1480
	3	3.5	0.103	1480	0.124	1480	0.153	1480	0.199	1480	0.328	980	0.136	1480
	3.5	4	0.118	1480	0.142	1480	0.174	1480	0.233	1480	0.398	980	0.155	1480
	4	4.5	0.133	1480	0.159	1480	0.196	1480	0.286	1480	0.468	980	0.174	1480
	>4*	*	*	1480	*	1480	*	1480	*	1480	*	980	CONSULT ENGINEERING	

Minimum Required Pipeline Wall Thickness† (in inches) For Listed Design Factor (DF) and Maximum Working Pressure (in psi)														
Per ASME B31.4, ASME B31.8 and CSA Z662 CAT I at -20°F to 250°F													Per ASME B31.3 at -20°F to 250°F	
12390990 1.25in BRANCH CONNECTION	Nominal Pipeline Size	Pipe OD (in)	0.72 DF	Pressure	0.6 DF	Pressure	0.5 DF	Pressure	0.4 DF	Pressure	0.2 DF	Pressure		
	1.5	1.9	0.057	1480	0.070	1480	0.086	1480	0.112	1480	0.150	940	0.077	1480
	2	2.375	0.071	1480	0.087	1480	0.107	1480	0.139	1480	0.188	940	0.096	1480
	2.5	2.875	0.086	1480	0.105	1480	0.130	1480	0.169	1480	0.227	940	0.115	1480
	3	3.5	0.105	1480	0.128	1480	0.158	1480	0.205	1480	0.282	940	0.139	1480
	3.5	4	0.119	1480	0.146	1480	0.180	1480	0.235	1480	0.350	940	0.159	1480
	4	4.5	0.134	1480	0.165	1480	0.203	1480	0.264	1480	0.417	940	0.178	1480
	5	5.563	0.166	1480	0.203	1480	0.250	1480	0.373	1480	0.559	940	0.220	1480
	>5*	*	*	1480	*	1480	*	1480	*	1480	*	940	CONSULT ENGINEERING	

Minimum Required Pipeline Wall Thickness† (in inches) For Listed Design Factor (DF) and Maximum Working Pressure (in psi)														
Per ASME B31.4, ASME B31.8 and CSA Z662 CAT I at -20°F to 250°F													Per ASME B31.3 at -20°F to 250°F	
12391385 2in BRANCH CONNECTION	Nominal Pipeline Size	Pipe OD (in)	0.72 DF	Pressure	0.6 DF	Pressure	0.5 DF	Pressure	0.4 DF	Pressure	0.2 DF	Pressure		
	2	2.375	0.072	1480	0.089	1480	0.109	1480	0.117	1255	0.116	625	0.093	1445
	2.5	2.875	0.087	1480	0.107	1480	0.132	1480	0.141	1255	0.140	625	0.113	1445
	3	3.5	0.106	1480	0.130	1480	0.160	1480	0.172	1255	0.171	625	0.136	1445
	3.5	4	0.121	1480	0.149	1480	0.183	1480	0.196	1255	0.195	625	0.155	1445
	4	4.5	0.137	1480	0.167	1480	0.206	1480	0.221	1255	0.220	625	0.175	1445
	5	5.563	0.169	1480	0.207	1480	0.255	1480	0.273	1255	0.271	625	0.215	1445
	6	6.625	0.201	1480	0.246	1480	0.303	1480	0.324	1255	0.323	625	0.256	1445
	8	8.625	0.261	1480	0.320	1480	0.411	1480	0.462	1255	0.458	625	0.332	1445
>8*	8.625*	*	1480	*	1480	*	1480	*	1255	*	625	CONSULT ENGINEERING		

The Maximum Working Pressures listed in these tables are valid for the stated pipeline size provided the pipeline minimum yield strength is greater than or equal to 35ksi and the pipeline wall thickness is greater than or equal to the value listed in these tables. Contact TDW Engineering for applications involving pipeline minimum yield strengths less than 35ksi or pipeline wall thicknesses less than those stated above.

* Exempt from reinforcement calculations per Table 404.3.4-1 of ASME B31.4 or Table 831.4.2-1 of ASME B31.8 or Table 4.6 of CSA Z662.

† Maximum Working Pressure values assume 35ksi minimum yield strength for pipeline (header) material.



3-WAY THREAD-O-RING™ Fittings

Dimensions

Size		CD		CH		PD		PH		FH		OH		OL		A	
Inches	DN	Inches	mm	Inches	mm	Inches	mm	Inches	mm	Inches	mm	Inches	mm	Inches	mm	Inches	mm
1	25	2.5	63.5	1.75	44.5	1.503	38.2	1.75	44.5	5	127.0	2.25	57.2	2	50.8	4.834	122.7
1.25	32	2.5	63.5	1.75	44.5	1.503	38.2	1.75	44.5	5.125	130.2	2.25	57.2	2	50.8	4.906	124.5
2	50	3	76.2	1.88	47.8	1.863	47.3	1.75	44.5	5.937	150.8	2.937	74.6	2.188	55.6	5.616	142.5

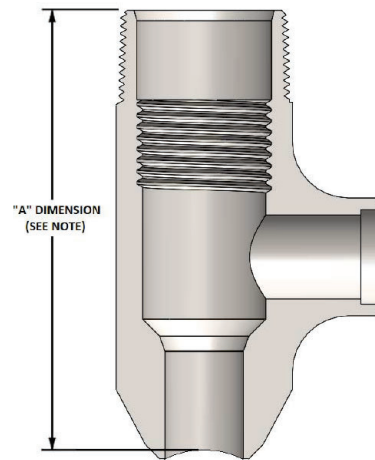
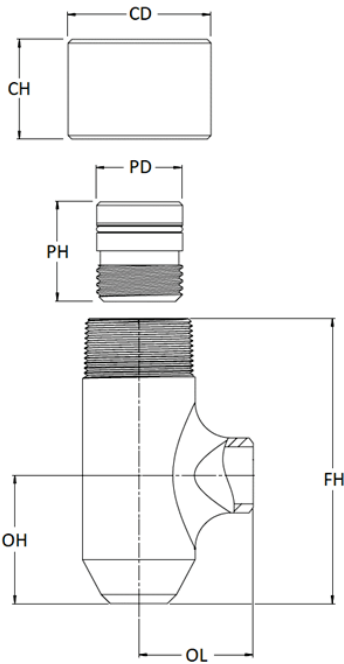

Scarfig Instructions

IF PART NEEDS TO BE MODIFIED TO FIT TO THE PIPELINE, THEN THE "A" DIMENSION SHALL BE MAINTAINED AT A MINIMUM, IN THE PERPENDICULAR ORIENTATION AS SHOWN, TO ENSURE ADEQUATE REINFORCEMENT FOR RATING. "A" DIMENSION SHALL BE EQUAL ON BOTH SIDES OF FITTING, AND THE WELD BEVEL CONTOUR SHALL PROVIDE A UNIFORM GAP BETWEEN THE FITTING WELD PREP AND THE PIPELINE AROUND THE ENTIRE CIRCUMFERENCE. CUSTOMER IS RESPONSIBLE FOR ENSURING THAT THE FITTING IS MODIFIED PROPERLY, OTHERWISE, THE WARRANTY MAY BE VOIDED. SIZE-ON-SIZE SCARFING IS NOT ALLOWED.



3-WAY THREAD-O-RING™ Fittings

Temporary 3-WAY THREAD-O-RING™ PLUG Isolation Plug

Size		
Inches	DN	Part Number
1	25	12390850
1.25	32	12390876
2	50	12390885