





Data Sheet No. **SSII-1-1/4**

**Fittings**

# **Tapping and *SHORTSTOPP*® II Plugging Machine**

## **1-1/4-inch Gas Main**

Data Sheet No. **SSII-1-1/4**



■ **Welding Fitting**  
See Bulletin 2100.003



■ **3-WAY™ Tee**  
See Bulletin 2100.002

■ **Note:** Consult your TDW representative for additional fitting options.





# SHORTSTOPP® II 2-inch Plugging Machine



**MAOP up to 200 psi at 100°F**

(see chart below for nosepiece and sealing element pressure rating)

Data Sheet No. **SSII-2**

Date: December 202

Supersedes: October 2020

## Tapping

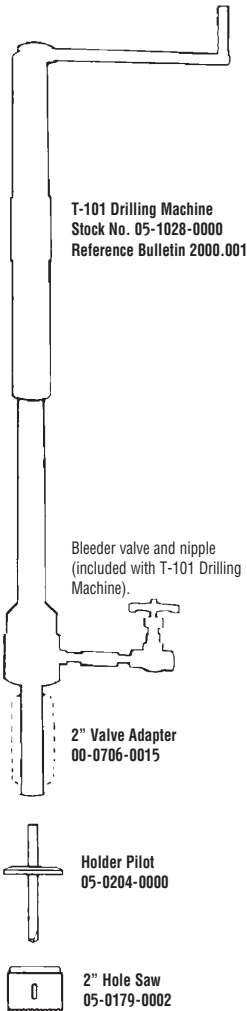

## Plugging

### 2" Plugging Machine Assembly 08-3309-0000

Includes items below

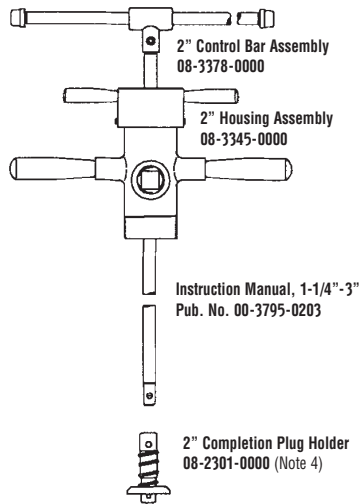

### 2" Standard Plugging Head Assembly 08-3306-0000

Includes items below



Sealing Element Not Included (Note 5)

### Bleeder Valve Accessory

Purchased separately

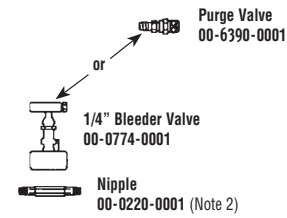

Carrying case for plugging machine  
sold separately 08-2481-0006

**2" SHORTCUTT® Valve**  
09-0758-0000  
500 psi MWP



**2" 3-WAY™ Tee**  
26-0217-0000-00 (Note 3)

**2" Welding Fitting**  
26-0212-0000-00 (Note 3)

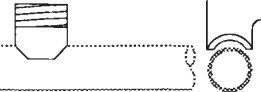

2" Steel Pipe

Refer to back for fitting options.

## Notes

- Maximum Working Pressure and Temperature:** 60 psi at 180°F with standard plugging head components; with special cups, 200 psi at 100°F or 120 psi at 180°F (see chart at right). Pressure rating may be limited by valve selection.
- Bleeder valve and nipple** are provided with TDW Drilling Machines.
- Fitting** - Includes threaded completion plug and cap.
- Solid Completion Plug Holder** - 08-0367-0001.
- Sealing Elements** - Refer to chart at right.

60 psi MWP Pipe ID	60 psi MWP Part No.	200 psi MWP Pipe ID	200 psi MWP Part No.
2.126-2.157	08-0501-0200-00	2.062-2.157	08-3427-0002-00
2.062-2.125	08-0114-0002-00	2.000-2.061	08-3427-0002-01
2.000-2.061	08-0114-0002-01	1.938-1.999	08-3427-0002-02
1.939-1.999	08-0114-0002-02		

Consult factory for unlisted pipe ID.



Data Sheet No. **SSII-2**

**Fittings**

# Tapping and **SHORTSTOPP® II** Plugging Machine 2-inch Gas Main

Data Sheet No. **SSII-2**



■ **Welding Fitting**  
See Bulletin 2100.003



■ **Spherical 3-WAY™ Tee**  
See Bulletin 2100.007



■ **3-WAY™ Tee**  
See Bulletin 2100.002



■ **Mechanical SHORTSLEEVE™ Fitting**  
See Bulletin 2100.002

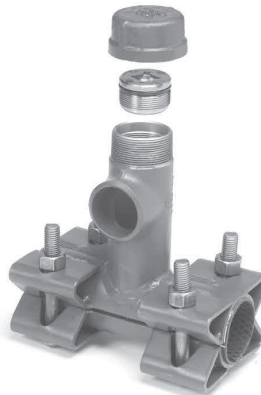

■ **Branch Type II 3-WAY™ Tee**  
See Bulletin 2100.011

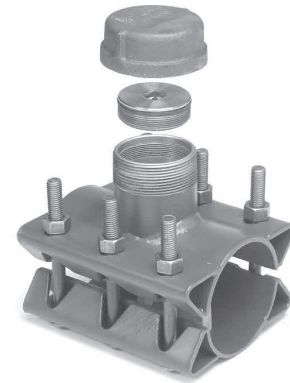

■ **Branch Type II Plugging Fitting**  
See Bulletin 2100.010

■ **Note:** Consult your TDW representative for additional fitting options.

North & South America: +1 918 447 5000 ■ Europe / Africa / Middle East: +32 67 28 3611 ■ Asia Pacific: +65 6364 8520 ■ [www.tdwilliamson.com](http://www.tdwilliamson.com)

Data subject to change without notice. / Dimensions not for construction unless certified. / © Registered trademark of T.D. Williamson in the United States and other countries. / TM Trademark of T.D. Williamson in the United States and other countries. / ©2020 T.D. Williamson

# SHORTSTOPP® II 3-inch Size-on-Size Plugging Machine

(1-inch Dia. Control Bar)

MAOP up to 200 psi at 100°F

(see chart below for sealing element pressure rating)



Data Sheet No. SSII-3

Date: October 2020

Supersedes: September 2004

## Tapping

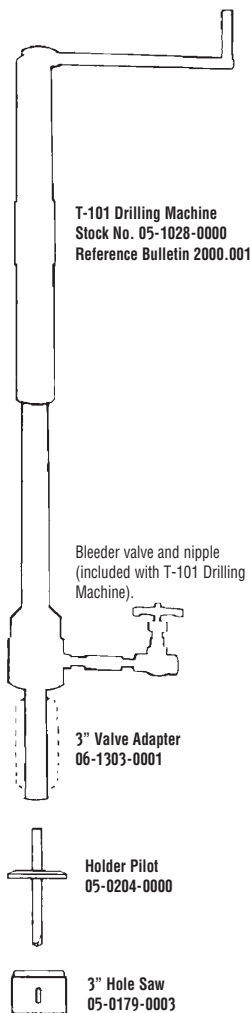

## Plugging

### 3" Plugging Machine Assembly 08-3500-0300

Includes items below

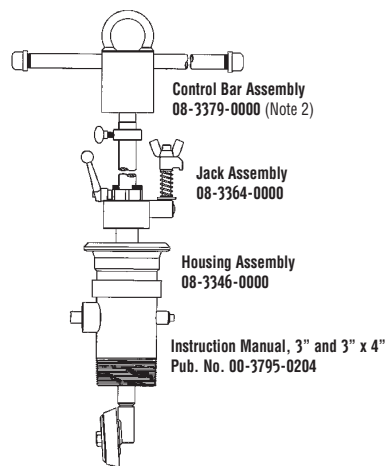

### Standard Plugging Head Assembly 08-3314-0000

Includes items below



Sealing Element Not Included (Note 6)

### Bleeder Valve Accessory

Purchased separately

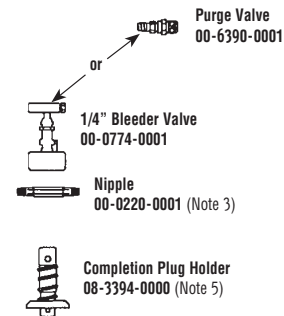

### 3" Sight Glass Kit 08-3423-0000-03

See Sight Glass Data Sheet for details

Carrying case for plugging machine  
sold separately 08-2481-0005

SHORTCUTT® Valve  
09-0759-0000  
500 psi MWP



3-WAY™ Tee  
26-0218-0000-00 (Note 4)

SHORTSTOPP® Welding Fitting  
26-0213-0000-00 (Note 4)

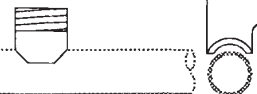

3" Steel Pipe

Refer to back for fitting options.

## Notes

- Maximum Working Pressure and Temperature:** 60 psi at 180°F with standard plugging head components; with special cups, 200 psi at 100°F or 120 psi at 180°F (see chart at right). Pressure rating may be limited by valve selection.
- 3" x 4" Control Bar Assembly** may be used with 3" Plugging Head Control Bar Adapter 08-3421-0002 for plugging 3" pipe.
- Bleeder valve and nipple** are provided with

- TDW Drilling Machines.**
- Fitting** - Includes threaded completion plug and cap.
- Solid Completion Plug Holder** - 08-3393-0000.
- Sealing Elements** - Refer to chart at right.

60 psi MWP Pipe ID	60 psi MWP Part No.	200 psi MWP Pipe ID	200 psi MWP Part No.
3.188-3.260	08-0502-0003-00	3.250-3.312	08-3428-0003-00
3.062-3.188	08-0114-0003-00	3.062-3.125	08-3427-0003-00
2.875-2.937	08-0114-0003-03	2.875-2.937	08-3427-0003-03

Consult factory for unlisted pipe ID.



Data Sheet No. **SSII-3**

**Fittings**

## **Tapping and *SHORTSTOPP*® II Plugging Machine 3-inch Gas Main**

Data Sheet No. **SSII-3**



■ **Welding Fitting**  
See Bulletin 2100.003



■ **Spherical 3-WAY™ Tee**  
See Bulletin 2100.007



■ **3-WAY™ Tee**  
See Bulletin 2100.002

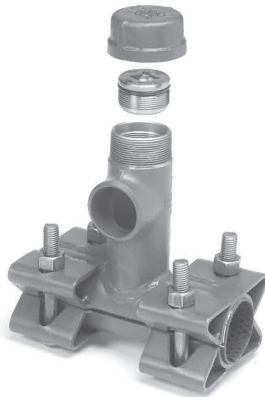

■ **Branch Type II 3-WAY™ Tee**  
See Bulletin 2100.011

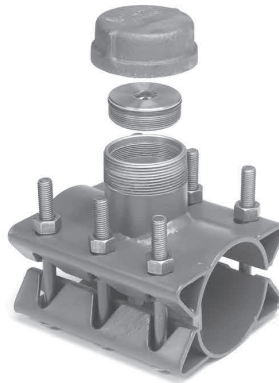

■ **Branch Type II Plugging Fitting**  
See Bulletin 2100.010

■ **Note:** Consult your TDW representative for additional fitting options.

North & South America: +1 918 447 5000 ■ Europe / Africa / Middle East: +32 67 28 3611 ■ Asia Pacific: +65 6364 8520 ■ [www.tdwilliamson.com](http://www.tdwilliamson.com)

Data subject to change without notice. / Dimensions not for construction unless certified. / © Registered trademark of T.D. Williamson in the United States and other countries. / TM Trademark of T.D. Williamson in the United States and other countries. / ©2020 T.D. Williamson



# SHORTSTOPP® II 4-inch Size-on-Size Plugging Machine

(1-inch Dia. Control Bar)

MAOP up to 200 psi at 100°F

(see chart below for sealing element pressure rating)



Data Sheet No. SSII-4

Date: October 2020

Supersedes: September 2004

## Tapping

- Note: Either the T-101 or T-203 Tapping Machine is recommended for 4" taps.

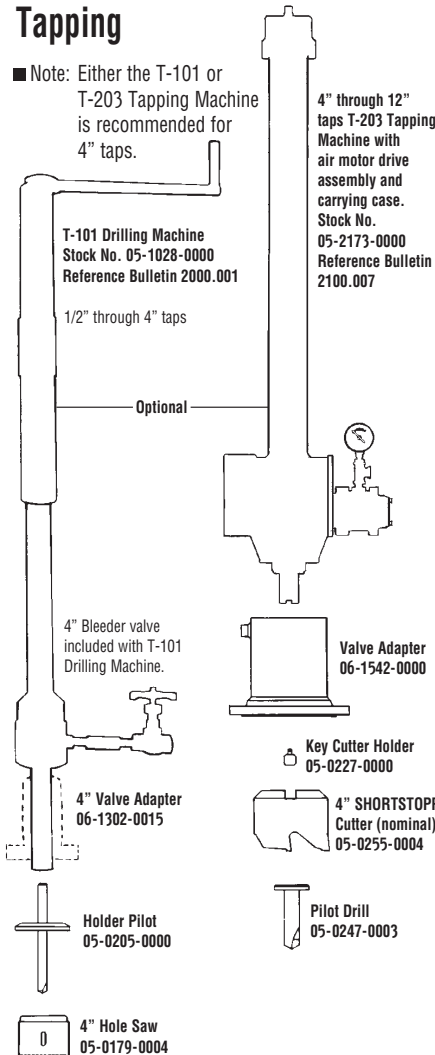

## Plugging

### 4" Plugging Machine Assembly 08-3500-0400

Includes items below

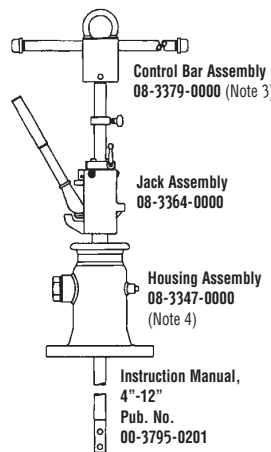

### Standard Plugging Head Assembly 08-3316-0000

Includes items below

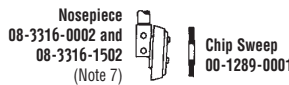

Sealing Element Not Included (Note 7)

### Bleeder Valve Accessory

Purchased separately

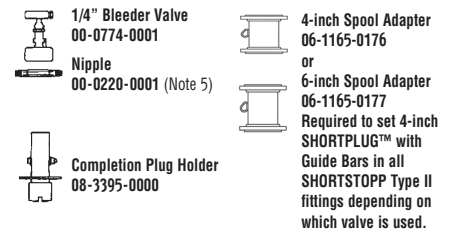

### Sight Glass Kit 08-3424-0000-01 (Note 2)

See Sight Glass Data Sheet for details

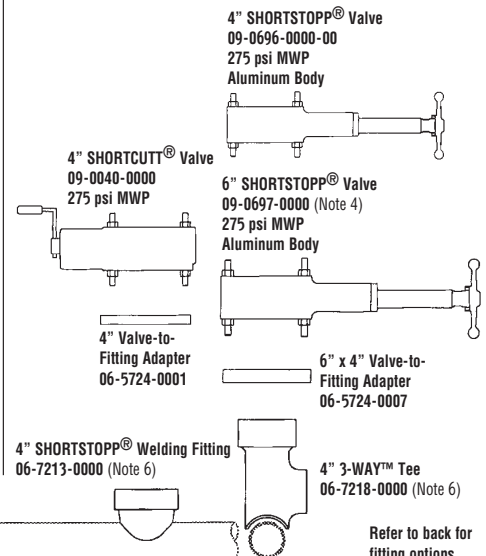

## Notes

- Maximum Working Pressure and Temperature:** 60 psi at 180°F with standard plugging head components; 200 psi at 100°F or 120 psi at 180°F, with special cups/nosepieces (see chart at right).
- Sight Glass Kit** - Requires the use of a T-203 Tapping Adapter. 4" Part No. 06-1542-0000 6" Part No. 06-1543-0000.
- 3" x 4" Control Bar Assembly** may also be used 08-3386-0000.
- If using a 6" SHORTCUTT® or SHORTSTOPP® Valve, use 4-6 PE Housing Assembly 08-3357-0000 and use 6" x 4" Tapping Adapter (f/T-101) 06-8872-0005.
- Bleeder valve and nipple** are provided with TDW Drilling Machines.
- Fitting** - Leaf-type completion plug and blind flange included.
- Sealing Elements** - Refer to chart at right. Use 08-3428-0004-03 to plug 4" 3-way tee outlet.

Pipe ID	60 psi MWP Sealing Element	60 psi MWP Nosepiece	Pipe ID	200 psi MWP Sealing Element	200 psi MWP Nosepiece
4.250-4.260	08-0502-0004-00	08-3316-1502	4.156-4.260	08-3428-0004-01	08-3316-1502
4.124-4.187	08-0502-0004-02	08-3316-1502	4.062-4.156	08-3428-0004-02	08-3316-1502
4.026-4.188	08-0114-0004-00	08-3316-0002	3.962-4.125	08-3428-0004-03	08-3316-1502
3.812-3.874	08-0114-0004-03	08-3316-0002	3.875-3.937	08-3427-0004-02	08-3316-0002
Consult factory for unlisted pipe ID.					
			3.812-3.874	08-3427-0004-03	08-3316-0002
			3.750 - 3.811	08-3427-0004-04	08-3316-0002



Data Sheet No. **SSII-4**

# Fittings

## Tapping and **SHORTSTOPP® II** Plugging Machine 4-inch Gas Main

Data Sheet No. **SSII-4**

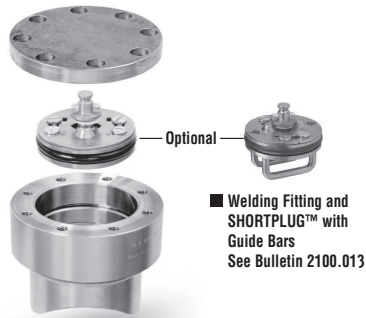

■ **Welding Fitting**  
See Bulletin 2100.003

■ **Welding Fitting and SHORTPLUG™ with Guide Bars**  
See Bulletin 2100.013

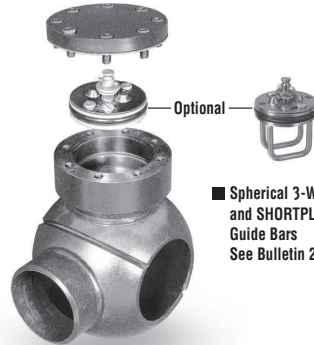

■ **Spherical 3-WAY™ Tee**  
See Bulletin 2100.007

■ **Spherical 3-WAY™ Tee and SHORTPLUG™ with Guide Bars**  
See Bulletin 2100.014

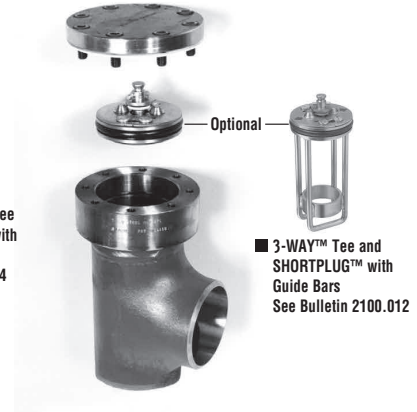

■ **3-WAY™ Tee**  
See Bulletin 2100.002

■ **3-WAY™ Tee and SHORTPLUG™ with Guide Bars**  
See Bulletin 2100.012



■ **Mechanical SHORTSLEEVE™ Fitting**  
See Bulletin 2110.001



■ **Branch Type II 3-WAY™ Tee**  
See Bulletin 2100.011

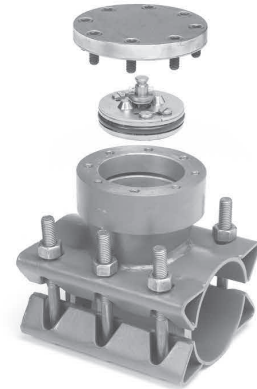

■ **Branch Type II Plugging Fitting**  
See Bulletin 2100.010

■ **Note:** Consult your TDW representative for additional fitting options.

North & South America: +1 918 447 5000 ■ Europe / Africa / Middle East: +32 67 28 3611 ■ Asia Pacific: +65 6364 8520 ■ [www.tdwilliamson.com](http://www.tdwilliamson.com)

Data subject to change without notice. / Dimensions not for construction unless certified. / © Registered trademark of T.D. Williamson in the United States and other countries. / TM Trademark of T.D. Williamson in the United States and other countries. / ©2020 T.D. Williamson

# SHORTSTOPP® II 6" Size-on-Size Plugging Machine

(1-5/8" Dia. Control Bar)

MAOP up to 200 psi at 100°F

(see chart below for sealing element pressure rating)



Data Sheet No. SSII-6

Date: October 2020

Supersedes: September 2004

## Tapping

■ Note: T-203 Tapping Machine is recommended for 6" taps.

4" through 12" taps T-203 Tapping Machine with air motor drive assembly and carrying case.  
Stock No. 05-2173-0000  
Reference Bulletin 2100.007.00

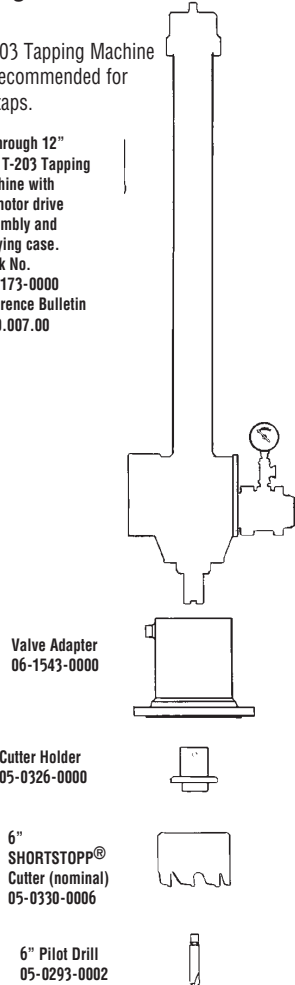

## Plugging

### 6" Plugging Machine Assembly 08-3500-0600

Includes items below

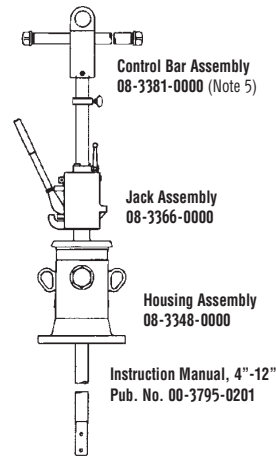

### Standard Plugging Head Assembly 08-3318-0000

Includes items below

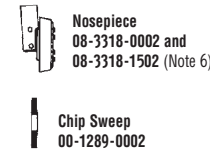

Sealing Element Not Included (Note 6)

### Bleeder Valve Accessory

Purchased separately



### Sight Glass Kit 08-3424-0000-02 (Note 2)

See Sight Glass Data Sheet for details

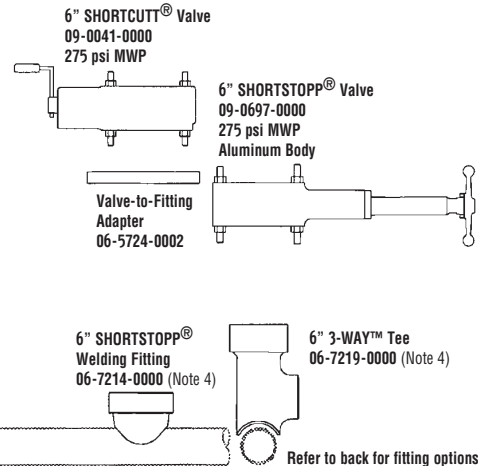

6" Steel Pipe

Refer to back for fitting options.

## Notes

1. Maximum Working Pressure and Temperature: 60 psi at 180°F with standard plugging head components; 200 psi at 100°F or 120 psi at 180°F, with special cups/nosepieces (see chart at right).
2. Sight Glass Kit - Requires the use of the 6" T-203 Tapping Adapter. Part No. 06-1543-0000.
3. Bleeder valve and nipple are provided with TDW Drilling Machines.
4. Fitting - Leaf-type completion plug and blind flange included.
5. 6" x 8" Control Bar Assembly 08-3388-0000 may also be used.
6. Sealing Elements - Refer to chart at right.

Pipe ID	60 psi MWP Sealing Element	60 psi MWP Nosepiece	Pipe ID	200 psi MWP Sealing Element	200 psi MWP Nosepiece
6.250-6.311	08-0502-0006-01	08-3318-1502	6.250-6.311	08-3428-0006-01	08-3318-1502
6.188-6.249	08-0502-0006-02	08-3318-1502	6.187-6.249	08-3428-0006-02	08-3318-1502
6.062-6.310	08-0114-0006-00	08-3318-0002	6.062-6.124	08-3428-0006-04	08-3318-1502
5.750-5.811	08-0114-0006-04	08-3318-0002	5.750-5.811	08-3427-0006-04	08-3318-0002

Consult factory for unlisted pipe ID.



Data Sheet No. **SSII-6**

# Fittings

## Tapping and **SHORTSTOPP® II** Plugging Machine 6" Gas Main

Data Sheet No. **SSII-6**



■ Welding Fitting  
See Bulletin 2100.003

■ Welding Fitting and  
**SHORTPLUG™** with  
Guide Bars  
See Bulletin 2100.013

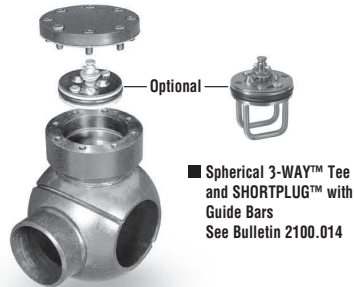

■ Spherical 3-WAY™ Tee  
See Bulletin 2100.007

■ Spherical 3-WAY™ Tee  
and **SHORTPLUG™** with  
Guide Bars  
See Bulletin 2100.014

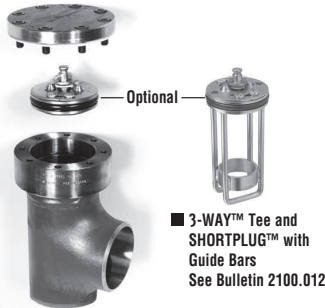

■ 3-WAY™ Tee  
See Bulletin 2100.002

■ 3-WAY™ Tee and  
**SHORTPLUG™** with  
Guide Bars  
See Bulletin 2100.012

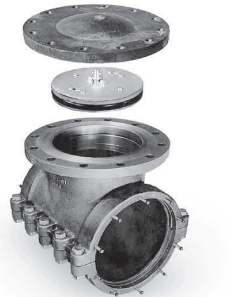

■ Mechanical **SHORTSLEEVE™** Fitting  
See Bulletin 2110.001



■ Branch Type II 3-WAY™ Tee  
See Bulletin 2100.011



■ Branch Type II Plugging Fitting  
See Bulletin 2100.010

■ Note: If you already have 8" **SHORTSTOPP®** plugging equipment, the additional accessories shown below are all you need to plug 6" mains (plus Welding Fittings).

6" x 8" Valve-to-Fitting Adapter  
06-5724-0004

6-inch Spool Adapter  
06-1165-0177  
Required to set 6-inch **SHORTPLUG™** with Guide Bars in all **SHORTSTOPP** Type II fittings.

6" **SHORTSTOPP®** Cutter  
(nominal)  
05-0446-0006

Pilot Drill  
05-0293-0002

Completion Plug Holder  
08-3396-0000

6" Plugging Head with Sealing Cup and Chip Sweep  
08-3318-0000

Cover Flange

Completion Plug

Fitting  
6" Welding Fitting includes:  
cover flange with bolts, gasket  
and plastic caplugs, completion  
plug and O-ring.  
Stock No. 06-5713-0000

■ Note: Consult your TDW representative for additional fitting options.

North & South America: +1 918 447 5000 ■ Europe / Africa / Middle East: +32 67 28 3611 ■ Asia Pacific: +65 6364 8520 ■ [www.tdwilliamson.com](http://www.tdwilliamson.com)

Data subject to change without notice. / Dimensions not for construction unless certified. / © Registered trademark of T.D. Williamson in the United States and other countries. / TM Trademark of T.D. Williamson in the United States and other countries. / ©2020 T.D. Williamson

Data Sheet No.  
SSII-8

# SHORTSTOPP® II 8" Size-on-Size Plugging Machine

(1-5/8" Dia. Control Bar)

MAOP up to 150 psi at 100°F

(see chart below for sealing element pressure rating)



Data Sheet No. SSII-8

Date: October 2020

Supersedes: September 2004

## Tapping

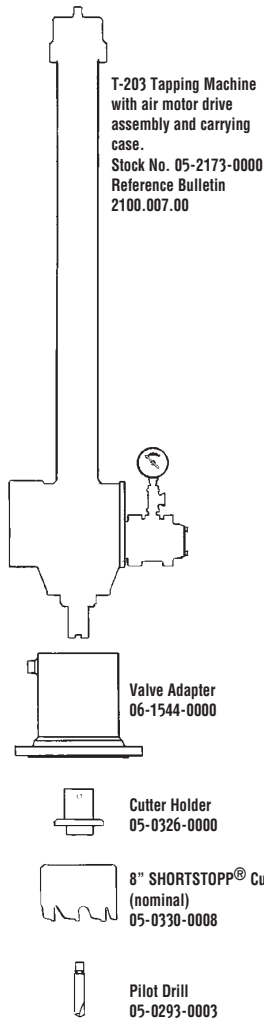

## Plugging

### 8" Plugging Machine Assembly 08-3500-0800

Includes items below

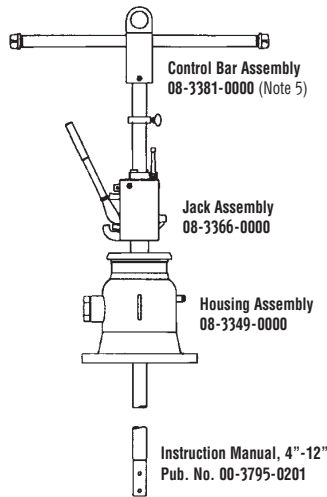

### Standard Plugging Head Assembly 08-3320-0000

Includes items below

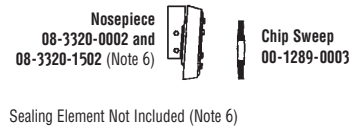

### Bleeder Valve Accessory

Purchased separately

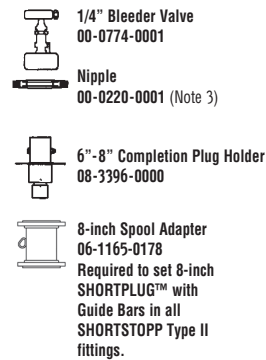

### Sight Glass Kit 08-3424-0000-02 (Note 2)

See Sight Glass Data Sheet for details

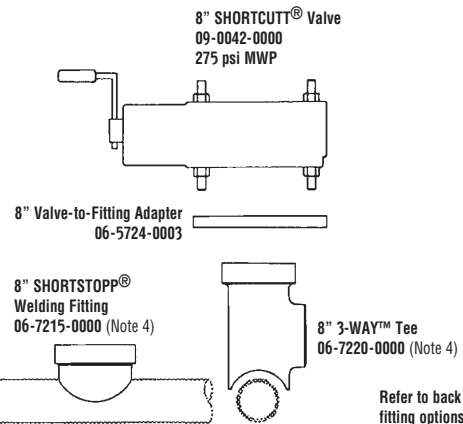

## Notes

1. **Maximum Working Pressure and Temperature:** 60 psi at 180°F with standard plugging head components; 150 psi at 100°F or 120 psi at 180°F, with special cups/nosepieces (see chart at right).
2. **Sight Glass Kit** - Requires the use of the 8" T-203 Tapping Adapter. Part No. 06-1544-0000.
3. **Bleeder valve and nipple** are provided with TDW Drilling Machines.
4. **Fitting** - Leaf-type completion plug and blind flange included.
5. 6" x 8" **Control Bar Assembly** may also be used.
6. **Sealing Elements** - Refer to chart at right.

Pipe ID	60 psi MWP		Pipe ID	150 psi MWP	
	Sealing Element	Nosepiece		Sealing Element	Nosepiece
8.250-8.280	08-1719-0008-01	08-3320-1502	8.281-8.311	08-3428-0008-01	08-3320-1502
8.188-8.249	08-1719-0008-02	08-3320-1502	8.250-8.280	08-3428-0008-02	08-3320-1502
7.938-8.281	08-0114-0008-00	08-3320-0002	7.981-8.000	08-3427-0008-00	08-3320-0002
7.625-7.687	08-0114-0008-05	08-3320-0002	7.625-7.687	08-3427-0008-06	08-3320-0002

Consult factory for unlisted pipe ID.

North & South America: +1 918 447 5000 ■ Europe / Africa / Middle East: +32 67 28 3611 ■ Asia Pacific: +65 6364 8520 ■ www.tdwilliamson.com

Data subject to change without notice. / Dimensions not for construction unless certified. / © Registered trademark of T.D. Williamson in the United States and other countries. / TM Trademark of T.D. Williamson in the United States and other countries. / ©2020 T.D. Williamson

Data Sheet No. SSII-8



Data Sheet No. **SSII-8**

# Fittings

## Tapping and **SHORTSTOPP® II** Plugging Machine 8" Gas Main

Data Sheet No. **SSII-8**

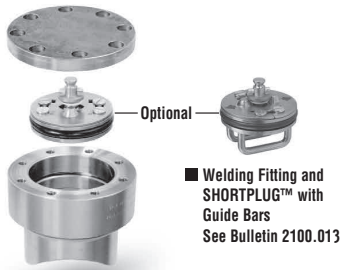

■ **Welding Fitting**  
See Bulletin 2100.003

■ **Welding Fitting and SHORTPLUG™ with Guide Bars**  
See Bulletin 2100.013

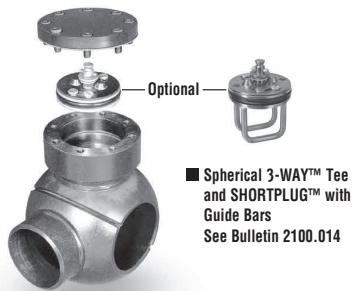

■ **Spherical 3-WAY™ Tee**  
See Bulletin 2100.007

■ **Spherical 3-WAY™ Tee and SHORTPLUG™ with Guide Bars**  
See Bulletin 2100.014

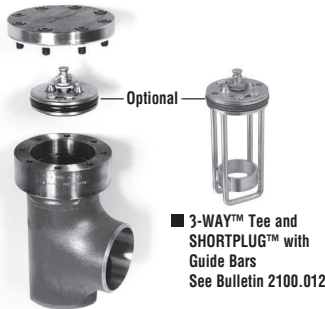

■ **3-WAY™ Tee**  
See Bulletin 2100.002

■ **3-WAY™ Tee and SHORTPLUG™ with Guide Bars**  
See Bulletin 2100.012

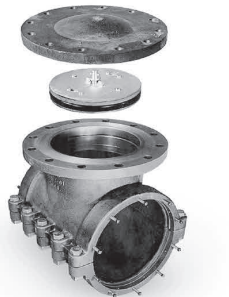

■ **Mechanical SHORTSLEEVE™ Fitting**  
See Bulletin 2110.001



■ **Branch Type II 3-WAY™ Tee**  
See Bulletin 2100.011



■ **Branch Type II Plugging Fitting**  
See Bulletin 2100.010

■ **Note:** If you already have 8" **SHORTSTOPP® II** plugging equipment, the additional accessories shown below are all that are needed to plug 6" mains (plus Welding Fittings).

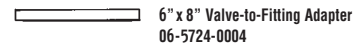

6" x 8" Valve-to-Fitting Adapter  
06-5724-0004

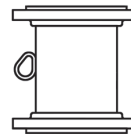

8-inch Spool Adapter  
06-1165-0178  
Required to set 8-inch **SHORTPLUG™** with Guide Bars in all **SHORTSTOPP Type II** fittings.



6" **SHORTSTOPP®** Cutter (nominal)  
05-0446-0006



Pilot Drill  
05-0293-0002



Completion Plug Holder  
08-3396-0000



6" Plugging Head with Sealing Cup and Chip Sweep  
08-3318-0000



Cover Flange

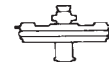

Completion Plug

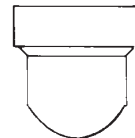

Fitting

6" Welding Fitting includes: cover flange with bolts, gasket and plastic caplugs, completion plug and O-ring.  
Stock No. 06-5713-0000

■ **Note:** Consult your TDW representative for additional fitting options.

North & South America: +1 918 447 5000 ■ Europe / Africa / Middle East: +32 67 28 3611 ■ Asia Pacific: +65 6364 8520 ■ [www.tdwilliamson.com](http://www.tdwilliamson.com)

Data subject to change without notice. / Dimensions not for construction unless certified. / © Registered trademark of T.D. Williamson in the United States and other countries. / TM Trademark of T.D. Williamson in the United States and other countries. / ©2020 T.D. Williamson

# SHORTSTOPP® II 10" Size-on-Size Plugging Machine

(2-1/2" Dia. Control Bar)

**MAOP up to 150 psi at 100°F**

(see chart below for sealing element pressure rating)



Data Sheet No. **SSII-10**

Date: October 2020

Supersedes: September 2004

## Tapping

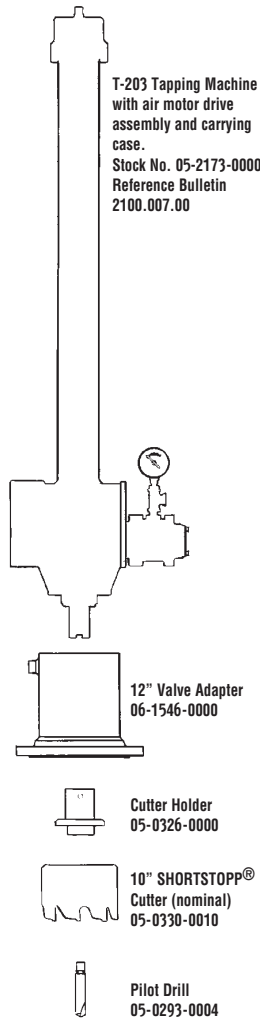

## Plugging

### 10" Plugging Machine Assembly 08-3500-1000

Includes items below

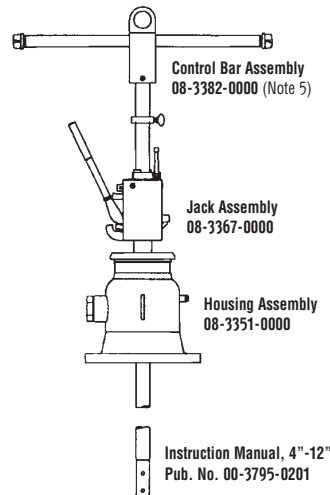

### Standard Plugging Head Assembly 08-3321-0000

Includes items below

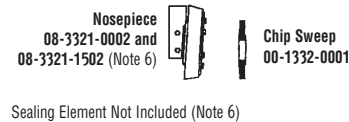

### Bleeder Valve Accessory

Purchased separately

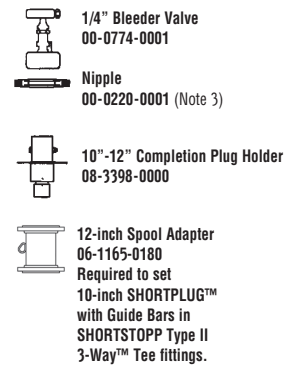

### Sight Glass Kit 08-3424-0000-02 (Note 2)

See Sight Glass Data Sheet for details

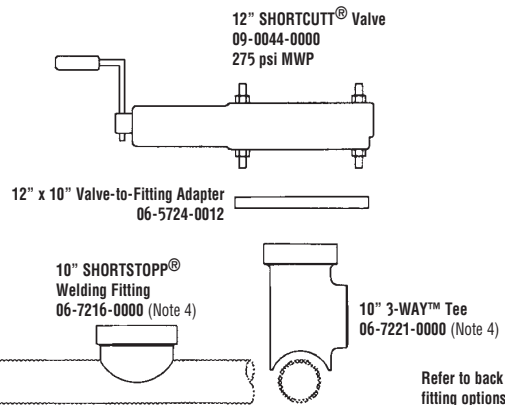

## Notes

- Maximum Working Pressure and Temperature:** 60 psi at 180°F with standard plugging head components; 150 psi at 100°F or 120 psi at 180°F, with special cups/nosepieces (see chart at right).
- Sight Glass Kit** - Requires the use of the 12" T-203 Tapping Adapter. Part No. 06-1546-0000.
- Bleeder valve and nipple** are provided with TDW Drilling Machines.
- Fitting** - Leaf-type completion plug and blind flange included.
- 8" x 12" Control Bar Assembly** Part No. 08-3389-0000 may also be used.
- Sealing Elements** - Refer to chart at right.

Pipe ID	60 psi MWP Sealing Element	60 psi MWP Nosepiece	Pipe ID	150 psi MWP Sealing Element	150 psi MWP Nosepiece
10.312-10.374	08-1719-0010-01	08-3321-1502	10.312-10.374	08-3428-0010-01	08-3321-1502
10.250-10.311	08-1719-0010-02	08-3321-1502	10.250-10.311	08-3428-0010-02	08-3321-1502
9.938-10.375	08-0114-0010-00	08-3321-0002	10.000-10.062	08-3427-0010-00	08-3321-0002
9.750-9.811	08-0114-0010-03	08-3321-0002	9.750-9.811	08-3427-0010-04	08-3321-0002

Consult factory for unlisted pipe ID.



Data Sheet No. **SSII-10**

# Fittings

## Tapping and **SHORTSTOPP® II** Plugging Machine 10" Gas Main

Data Sheet No. **SSII-10**

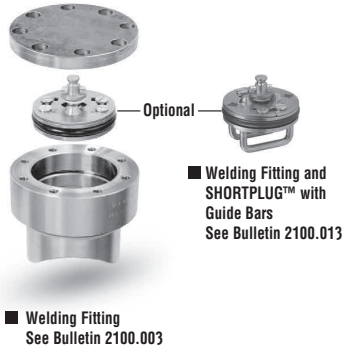

■ Note: If you already have 12" SHORTSTOPP® II plugging equipment, the additional accessories shown below are all that are needed to plug 10" mains (plus Welding Fittings).

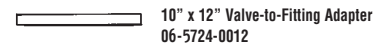

10" SHORTCUTT® Valve not available. The 10" SHORTSTOPP® II Plugging Machine is equipped with 12" housing for use with 12" SHORTCUTT® Valve and 10" x 12" adapter.

■ Note: Consult your TDW representative for additional fitting options.

North & South America: +1 918 447 5000 ■ Europe / Africa / Middle East: +32 67 28 3611 ■ Asia Pacific: +65 6364 8520 ■ [www.tdwilliamson.com](http://www.tdwilliamson.com)

Data subject to change without notice. / Dimensions not for construction unless certified. / © Registered trademark of T.D. Williamson in the United States and other countries. / TM Trademark of T.D. Williamson in the United States and other countries. / ©2020 T.D. Williamson



# SHORTSTOPP® II 12" Size-on-Size Plugging Machine

(2-1/2" Dia. Control Bar)

**MAOP up to 150 psi at 100°F**

(see chart below for sealing element pressure rating)



Data Sheet No. **SSII-12**

Date: October 2020

Supersedes: September 2004

## Tapping

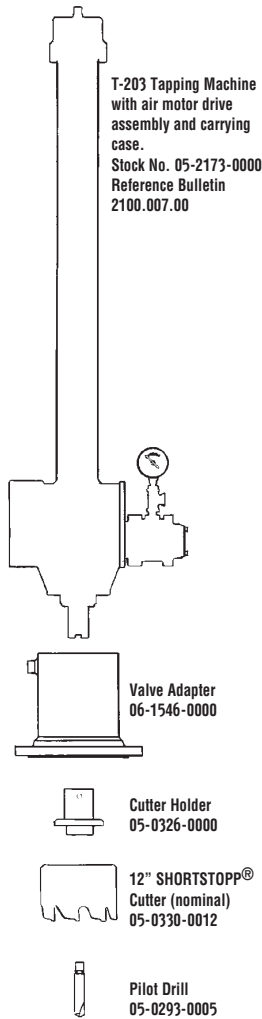

## Plugging

### 12" Plugging Machine Assembly 08-3500-1200

Includes items below

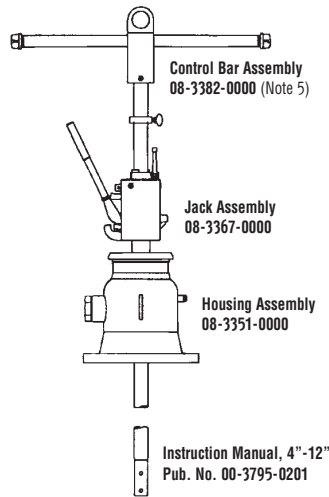

### Standard Plugging Head Assembly 08-3322-0000

Includes items below

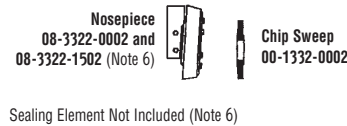

### Bleeder Valve Accessory

Purchased separately

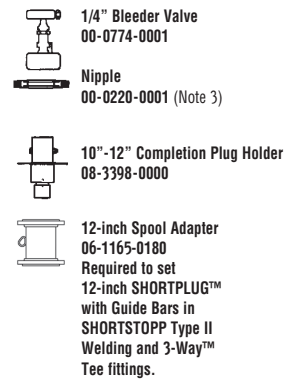

### Sight Glass Kit 08-3424-0000-02 (Note 2)

See Sight Glass Data Sheet for details

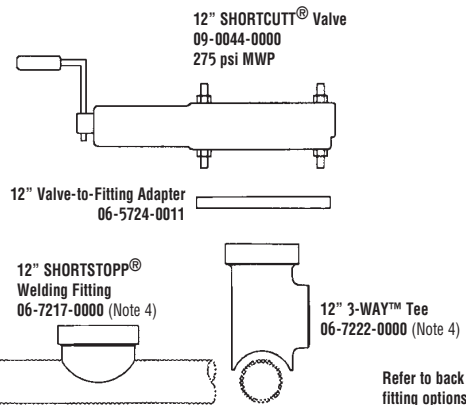

## Notes

- Maximum Working Pressure and Temperature:** 60 psi at 180°F with standard plugging head components; 150 psi at 100°F or 120 psi at 180°F, with special cups/nosepieces (see chart at right).
- Sight Glass Kit** - Requires the use of the 12" T-203 Tapping Machine. Part No. 06-1546-0000.
- Bleeder valve and nipple** are provided with TDW Drilling Machines.
- Fitting** - Leaf-type completion plug and blind flange included.
- 8" x 12" Control Bar Assembly** Part No. 08-3389-0000 may also be used.
- Sealing Elements** - Refer to chart at right.

Pipe ID	60 psi MWP Sealing Element	60 psi MWP Nosepiece	Pipe ID	150 psi MWP Sealing Element	150 psi MWP Nosepiece
12.250-12.311	08-1719-0012-02	08-3322-1502	12.250-12.311	08-3428-0012-02	08-3322-1502
12.062-12.124	08-1719-0012-05	08-3322-1502	12.000-12.061	08-3428-0012-06	08-3322-1502
11.938-12.375	08-0114-0012-00	08-3322-0002	11.938-11.999	08-3427-0012-00	08-3322-0002
11.750-11.811	08-0114-0012-03	08-3322-0002	11.750-11.811	08-3427-0012-03	08-3322-0002

Consult factory for unlisted pipe IDs.



Data Sheet No. **SSII-12**

# Fittings

Data Sheet No. **SSII-12**

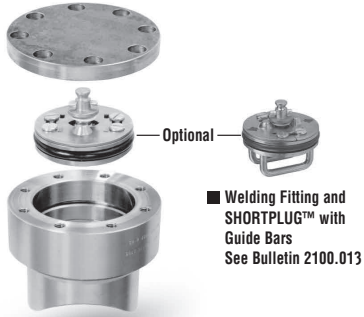

■ **Welding Fitting and SHORTPLUG™ with Guide Bars**  
See Bulletin 2100.013

■ **Welding Fitting**  
See Bulletin 2100.003

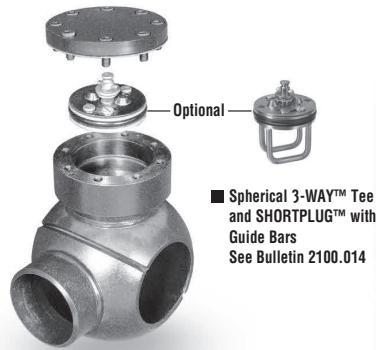

■ **Spherical 3-WAY™ Tee and SHORTPLUG™ with Guide Bars**  
See Bulletin 2100.014

■ **Spherical 3-WAY™ Tee**  
See Bulletin 2100.007

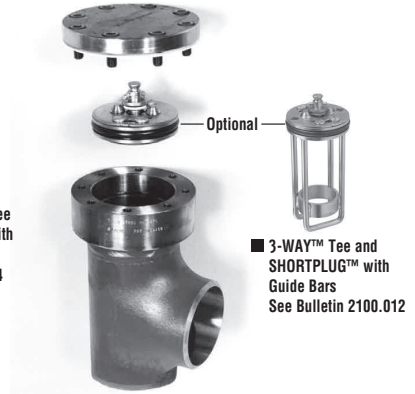

■ **3-WAY™ Tee and SHORTPLUG™ with Guide Bars**  
See Bulletin 2100.012

■ **3-WAY™ Tee**  
See Bulletin 2100.002



■ **Mechanical SHORTSLEEVE™ Fitting**  
See Bulletin 2110.001



■ **Branch Type II 3-WAY™ Tee**  
See Bulletin 2100.011



■ **Branch Type II Plugging Fitting**  
See Bulletin 2100.010

■ Note: Consult your TDW representative for additional fitting options.

North & South America: +1 918 447 5000 ■ Europe / Africa / Middle East: +32 67 28 3611 ■ Asia Pacific: +65 6364 8520 ■ [www.tdwilliamson.com](http://www.tdwilliamson.com)

Data subject to change without notice. / Dimensions not for construction unless certified. / © Registered trademark of T.D. Williamson in the United States and other countries. / TM Trademark of T.D. Williamson in the United States and other countries. / ©2020 T.D. Williamson

Data Sheet No.  
SSII-3x4

# SHORTSTOPP® II 3" x 4" Reduced Branch Plugging Machine

(1" Dia. Control Bar)

MAOP up to 150 psi at 100°F

(see chart below for sealing element pressure rating)



Data Sheet No. SSII-3x4

Date: October 2020

Supersedes: September 2004

Data Sheet No. SSII-3x4

## Tapping

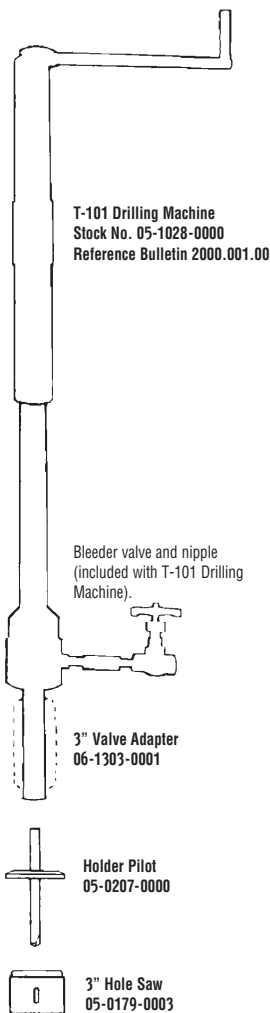

## Plugging

### 3" x 4" Plugging Machine Assembly 08-3501-0304

Includes items below

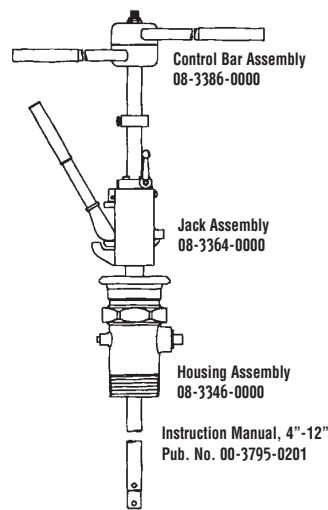

### Standard Plugging Head Assembly 08-3326-0000

Includes items below



Chip Sweep (see Note 3) or Sight Glass  
Sealing Element Not Included (Note 6)

### Bleeder Valve Accessory

Purchased separately

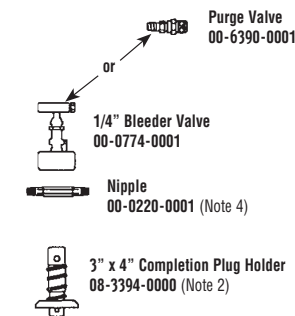

### Sight Glass Kit 08-3423-0000-03

See Sight Glass Data Sheet for details

Carrying case for plugging machine  
sold separately 08-2481-0004

3" SHORTCUT® Valve  
09-0759-0000  
500 psi MWP



3" x 4" SHORTSTOPP®  
Welding Fitting  
26-0324-0000 (Note 5)



3" x 4" 3-WAY™ Tee  
26-0325-0000-01  
Standard Outlet  
26-0325-0000-02  
Thinwall Outlet  
(Note 3 and Note 5)



Refer to back for fitting options.

4" Steel Pipe

## Notes

- Maximum Working Pressure and Temperature:** 150 psi at 100°F or 120 psi at 180°F. Special cups and/or nosepieces may be required (see chart at right). Pressure rating may be limited by valve selection.
- Solid Completion Plug Holder** - 08-3393-0000
- 3" Plugging Head Kit** adapts folding head plugging to plug 3" size-on-size lines and 3-WAY™ Tee Outlet. Kit 08-3421-0000 includes Plugging Head Assembly 08-3314-0000, chip sweep, and control bar adapter.
- Bleeder valve and nipple** are provided with TDW Drilling Machines.
- Fitting** - Includes threaded completion plug and cap.
- Sealing Elements** - Refer to chart at right.

Pipe ID	150 psi MWP Sealing Element	150 psi MWP Nosepiece
4.188-4.260	08-2332-0004-00	08-3326-0004
4.062-4.125	08-2332-0004-01	08-3326-0004
3.938-4.026	08-2332-0004-02	08-3326-0004
3.750-3.826	08-2332-0004-03	08-3326-0104

Consult factory for unlisted Pipe ID's.

North & South America: +1 918 447 5000 ■ Europe / Africa / Middle East: +32 67 28 3611 ■ Asia Pacific: +65 6364 8520 ■ [www.tdwilliamson.com](http://www.tdwilliamson.com)

Data subject to change without notice. / Dimensions not for construction unless certified. / © Registered trademark of T.D. Williamson in the United States and other countries. / TM Trademark of T.D. Williamson in the United States and other countries. / ©2020 T.D. Williamson



Data Sheet No. **SSII-3x4**

**Fittings**

# **Tapping and *SHORTSTOPP*® II Plugging Machine** **3" x 4" Gas Main**

Data Sheet No. **SSII-3x4**



■ **Welding Fitting**  
See Bulletin 2100.003.00



■ **3-WAY™ Tee**  
See Bulletin 2100.002.00

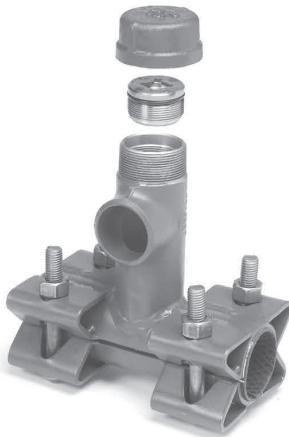

■ **Branch Type II 3-WAY™ Tee**  
See Bulletin 2100.011

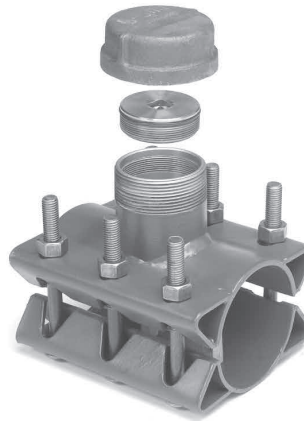

■ **Branch Type II Plugging Fitting**  
See Bulletin 2100.010

■ **Note:** Consult your TDW representative for additional fitting options.

North & South America: +1 918 447 5000 ■ Europe / Africa / Middle East: +32 67 28 3611 ■ Asia Pacific: +65 6364 8520 ■ [www.tdwilliamson.com](http://www.tdwilliamson.com)

Data subject to change without notice. / Dimensions not for construction unless certified. / © Registered trademark of T.D. Williamson in the United States and other countries. / TM Trademark of T.D. Williamson in the United States and other countries. / ©2020 T.D. Williamson

Data Sheet No.  
SSII-4x6

# SHORTSTOPP® II 4" x 6" Reduced Branch Plugging Machine

(1-1/4" Dia. Control Bar)

MAOP up to 150 psi at 100°F

(see chart below for sealing element pressure rating)



Data Sheet No. SSII-4x6

Date: October 2020

Supersedes: September 2004

## Tapping

Note: Either the T-101 or T-203 Tapping Machine is recommended for 4" taps.

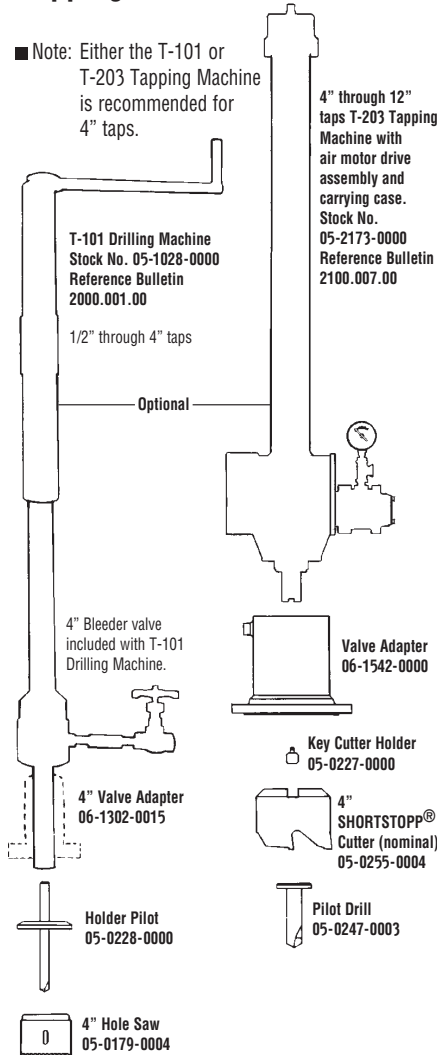

## Plugging

### 4" x 6" Plugging Machine Assembly 08-3501-0406 (with 6" Housing 08-3511-0406)

Includes items below

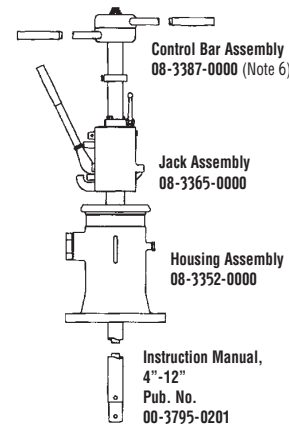

### Standard Plugging Head Assembly 08-3327-0000

Includes items below



Chip Sweep (see Note 6) or Sight Glass  
Sealing Cup Not Included (Note 7)

### Bleeder Valve Accessory

Purchased separately



### Sight Glass Kit 08-3424-0000-01 (Note 3)

See Sight Glass Data Sheet for details

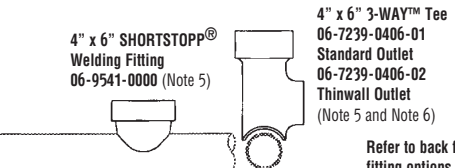
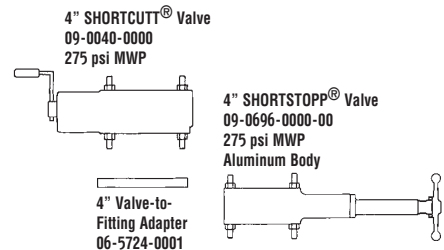

6" Steel Pipe

Refer to back for fitting options.

## Notes

- Maximum Working Pressure and Temperature:** 150 psi at 100°F or 120 psi at 180°F. Special cups and/or nosepieces may be required (see chart at right).
- Use 4" x 6" Pilot Drill** when making these **reduced branch taps**: use 05-0228-0000 with T-101 and 05-0247-0004 with 360, T-203. Special Tapping Adapter 06-8872-0005 required with T-101 when using with 6" valve.
- Sight Glass Kit** - Requires the use of the 4" T-203 Tapping Adapter. Part No. 06-1542-0000
- Bleeder valve and nipple** are provided with TDW Drilling

- Machines.**
- Fitting** - Leaf-type completion plug and blind flange included.
- 4" Plugging Head Kit** adapts 1-1/4" control bar to plug 4" size-on-size lines and 3-WAY™ Tee Outlet. Kit 08-3419-0000 includes Plugging Head Assembly 08-3316-0000, chip sweep, control bar adapter and spacer.
- Sealing Elements** - Refer to chart at right.

Pipe ID	150 psi MWP Sealing Element	150 psi MWP Nosepiece
6.250-6.357	08-2332-0006-00	08-3327-1504
6.125-6.188	08-2332-0006-01	08-3327-1504
5.938-6.065	08-2332-0006-02	08-3327-0004
5.750-5.875	08-2332-0006-03	08-3327-0004

Consult factory for unlisted pipe IDs.

North & South America: +1 918 447 5000 ■ Europe / Africa / Middle East: +32 67 28 3611 ■ Asia Pacific: +65 6364 8520 ■ www.tdwilliamson.com

Data subject to change without notice. / Dimensions not for construction unless certified. / ® Registered trademark of T.D. Williamson in the United States and other countries. / TM Trademark of T.D. Williamson in the United States and other countries. / ©2020 T.D. Williamson

Data Sheet No. SSII-4x6



Data Sheet No. **SSII-4x6**

**Fittings**

## **Tapping and *SHORTSTOPP*® II Plugging Machine 4" x 6" Gas Main**

Data Sheet No. **SSII-4x6**



■ **Welding Fitting**  
See Bulletin 2100.003.00



■ **3-WAY™ Tee**  
See Bulletin 2100.002.00



■ **Branch Type II 3-WAY™ Tee**  
See Bulletin 2100.011

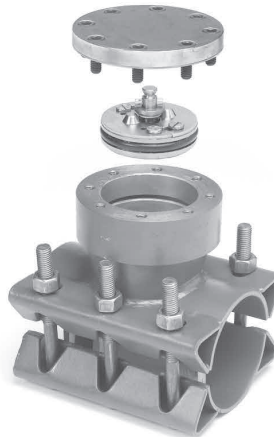

■ **Branch Type II Plugging Fitting**  
See Bulletin 2100.010

■ **Note:** Consult your TDW representative for additional fitting options.

North & South America: +1 918 447 5000 ■ Europe / Africa / Middle East: +32 67 28 3611 ■ Asia Pacific: +65 6364 8520 ■ [www.tdwilliamson.com](http://www.tdwilliamson.com)

Data subject to change without notice. / Dimensions not for construction unless certified. / © Registered trademark of T.D. Williamson in the United States and other countries. / TM Trademark of T.D. Williamson in the United States and other countries. / ©2020 T.D. Williamson

# SHORTSTOPP® II 6" x 8" Reduced Branch Plugging Machine

(1-5/8" Dia. Control Bar)

MAOP up to 150 psi at 100°F

(see chart below for sealing element pressure rating)



Data Sheet No. SSII-6x8

Date: October 2020

Supersedes: September 2004

## Tapping

■ Note: T-203 Tapping Machine is recommended for 6" taps.

T-203 Tapping Machine with air motor drive assembly and carrying case. Stock No. 05-2173-0000 Reference Bulletin 2100.007.00

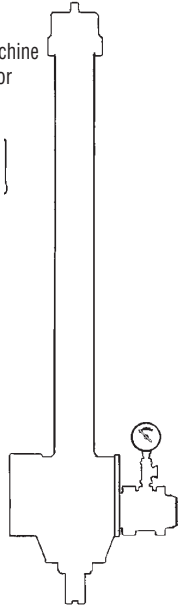

Valve Adapter  
06-1543-0000

Cutter Holder  
05-0326-0000

6" SHORTSTOPP®  
Cutter (nominal)  
05-0330-0006

Pilot Drill  
05-0293-0010

## Plugging

### 6" x 8" Plugging Machine Assembly 08-3501-0608

Includes items below

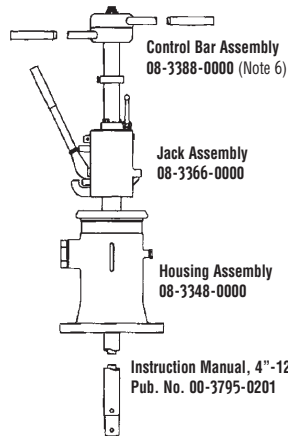

### Standard Plugging Head Assembly 08-3329-0000

Includes items below



Chip Sweep (see Note 6) or Sight Glass  
Sealing Element Not Included (Note 7)

### Bleeder Valve Accessory

Purchased separately



6" x 8" Completion Plug Holder  
08-3396-0000

### Sight Glass Kit 08-3424-0000-02 (Note 3)

See Sight Glass Data Sheet for details

6" SHORTCUTT® Valve  
09-0041-0000  
275 psi MWP

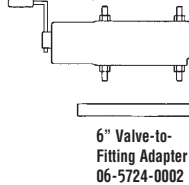

6" SHORTSTOPP® Valve  
09-0697-0000  
275 psi MWP  
Aluminum Body

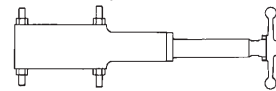

6" Valve-to-Fitting Adapter  
06-5724-0002

6" x 8" SHORTSTOPP®  
Welding Fitting  
06-9542-0000 (Note 5)

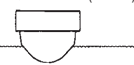

6" x 8" 3-WAY™ Tee  
06-7240-0608-01  
Standard Outlet  
06-7240-0608-02  
Thinwall Outlet  
(Note 5 and Note 6)

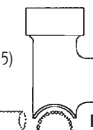

8" Steel Pipe

Refer to back for fitting options.

## Notes

- Maximum Working Pressure and Temperature:** 150 psi at 100°F or 120 psi at 180°F. Special cups and/or nosepieces may be required (see chart at right).
- Use 6" x 8" Pilot Drill** 05-0293-0010 when making these reduced branch taps.
- Sight Glass Kit** - Requires the use of the 6" T-203 Tapping Adapter, Part No. 06-1543-0000
- Bleeder valve and nipple** are provided with TDW Drilling Machines.
- Fitting** - Leaf-type completion plug and blind flange

- included.
- Control bar** can be used with 6" plugging head 08-3318-0000 (includes chipsweep) to plug 6" size-on-size lines and 3-WAY™ Tee Outlet.
- Sealing Elements** - Refer to chart at right.

Pipe ID	150 psi MWP Sealing Element	150 psi MWP Nosepiece
8.250-8.329	08-2332-0008-00	08-3329-1504
8.062-8.188	08-2332-0008-01	08-3329-1504
7.875-8.000	08-2332-0008-02	08-3329-0004
7.625-7.812	08-2332-0008-03	08-3329-0004

Consult factory for unlisted Pipe ID's.



Data Sheet No. **SSII-6x8**

**Fittings**

# **Tapping and *SHORTSTOPP*® II Plugging Machine 6" x 8" Gas Main**

Data Sheet No. **SSII-6x8**



■ **Welding Fitting**  
See Bulletin 2100.003.00



■ **3-WAY™ Tee**  
See Bulletin 2100.002.00



■ **Branch Type II 3-WAY™ Tee**  
See Bulletin 2100.011

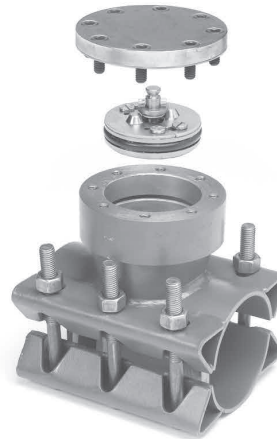

■ **Branch Type II Plugging Fitting**  
See Bulletin 2100.010

■ **Note:** Consult your TDW representative for additional fitting options.

North & South America: +1 918 447 5000 ■ Europe / Africa / Middle East: +32 67 28 3611 ■ Asia Pacific: +65 6364 8520 ■ [www.tdwilliamson.com](http://www.tdwilliamson.com)

Data subject to change without notice. / Dimensions not for construction unless certified. / © Registered trademark of T.D. Williamson in the United States and other countries. / TM Trademark of T.D. Williamson in the United States and other countries. / ©2020 T.D. Williamson



Data Sheet No.  
SSII-8x10

# SHORTSTOPP® II 8" x 10" Reduced Branch Plugging Machine

(2-1/2" Dia. Control Bar)

MAOP up to 150 psi at 100°F

(see chart below for sealing element pressure rating)



Data Sheet No. SSII-8x10

Date: October 2020

Supersedes: September 2004

Data Sheet No. SSII-8x10

## Tapping

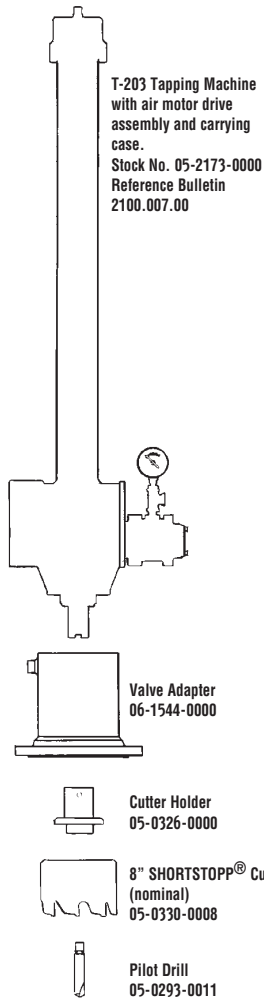

## Plugging

### 8" x 10" Plugging Machine Assembly 08-3501-0810

Includes items below

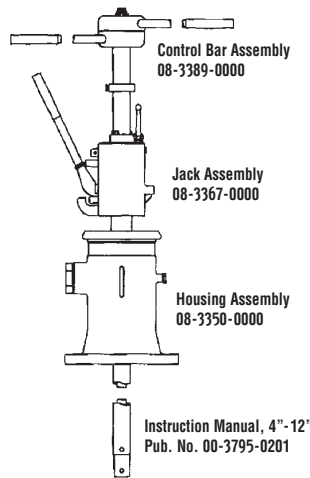

### Standard Plugging Head Assembly 08-3330-0000

Includes items below



Chip Sweep (see Note 6) or Sight Glass  
Sealing Element Not Included (Note 8)

### Bleeder Valve Accessory

Purchased separately

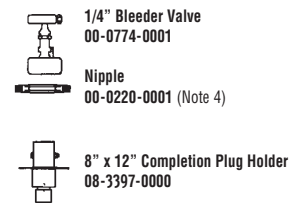

### Sight Glass Kit 08-3424-0000-02 (Note 3)

See Sight Glass Data Sheet for details

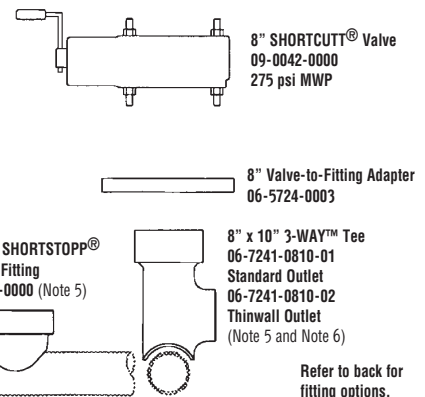

## Notes

- Maximum Working Pressure and Temperature:** 150 psi at 100°F or 120 psi at 180°F. Special cups and/or nosepieces may be required (see chart at right).
- Use 8" x 10" Pilot Drill** 05-0293-0011 for **reduced branch taps**. With 660/760 Tapping Machine use 8" x 12" Tapping Adapter 06-6102-0017.
- Sight Glass Kit** - Requires the use of the 8" T-203 Tapping Adapter. Part No. 06-1544-0000
- Bleeder valve and nipple** are provided with TDW Drilling Machines.
- Fitting** - Leaf-type completion plug and blind flange included.
- 8" Plugging Head Kit** adapts folding head plunger to plug 8" size-on-size lines and 3-WAY™ Tee Outlet. Kit 08-3420-0000 includes Plugging Head Assembly 08-3320-0000, chip sweep, and adapter.
- With an **8" x 12" Plugging Head**, Nosepiece and Cup, 12" pipe can be plugged. (See 8" x 12" Data Sheet.)
- Sealing Elements** - Refer to chart at right.

Pipe ID	150 psi MWP Sealing Element	150 psi MWP Nosepiece
10.250-10.375	08-2332-0010-00	08-3330-1504
10.062-10.188	08-2332-0010-01	08-3330-1504
9.938-10.020	08-2332-0010-02	08-3330-0004
9.688-9.875	08-2332-0010-03	08-3330-0004

Consult factory for unlisted Pipe ID's.

North & South America: +1 918 447 5000 ■ Europe / Africa / Middle East: +32 67 28 3611 ■ Asia Pacific: +65 6364 8520 ■ [www.tdwilliamson.com](http://www.tdwilliamson.com)

Data subject to change without notice. / Dimensions not for construction unless certified. / © Registered trademark of T.D. Williamson in the United States and other countries. / TM Trademark of T.D. Williamson in the United States and other countries. / ©2020 T.D. Williamson



Data Sheet No. **SSII-8x10**

**Fittings**

# **Tapping and *SHORTSTOPP*® II Plugging Machine**

## **8" x 10" Gas Main**

Data Sheet No. **SSII-8x10**



■ **Welding Fitting**  
See Bulletin 2100.003.00



■ **3-WAY™ Tee**  
See Bulletin 2100.002.00



■ **Branch Type II 3-WAY™ Tee**  
See Bulletin 2100.011



■ **Branch Type II Plugging Fitting**  
See Bulletin 2100.010

■ **Note:** Consult your TDW representative for additional fitting options.

North & South America: +1 918 447 5000 ■ Europe / Africa / Middle East: +32 67 28 3611 ■ Asia Pacific: +65 6364 8520 ■ [www.tdwilliamson.com](http://www.tdwilliamson.com)

Data subject to change without notice. / Dimensions not for construction unless certified. / © Registered trademark of T.D. Williamson in the United States and other countries. / TM Trademark of T.D. Williamson in the United States and other countries. / ©2020 T.D. Williamson

Data Sheet No.  
SSII-8x12

# SHORTSTOPP® II 8" x 12" Reduced Branch Plugging Machine

(2-1/2" Dia. Control Bar)

MAOP up to 150 psi at 100°F

(see chart below for sealing element pressure rating)



Data Sheet No. SSII-8x12

Date: October 2020

Supersedes: September 2004

Data Sheet No. SSII-8x12

## Tapping

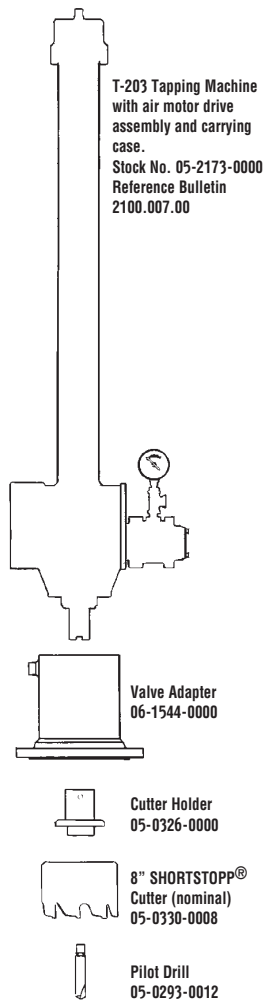

## Plugging

### 8" x 12" Plugging Machine Assembly 08-3501-0812

Includes items below

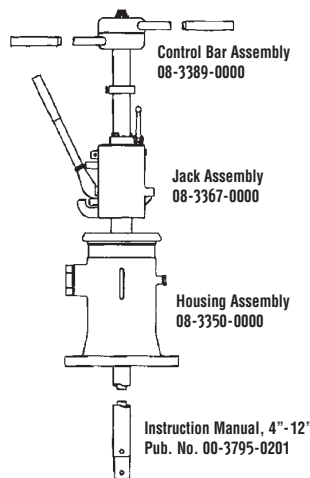

### Standard Plugging Head Assembly 08-3331-0000

Includes items below



Chip Sweep (see Note 6) or Sight Glass  
Sealing Element Not Included (Note 8)

### Bleeder Valve Accessory

Purchased separately

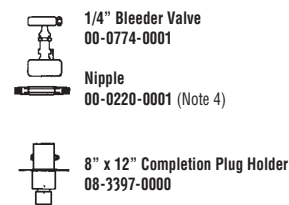

### Sight Glass Kit 08-3424-0000-02 (Note 3)

See Sight Glass Data Sheet for details

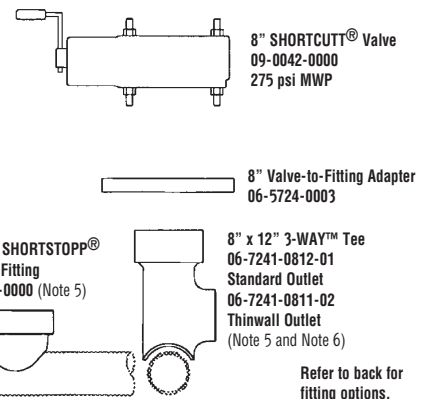

## Notes

- Maximum Working Pressure and Temperature:** 150 psi at 100°F or 120 psi at 180°F. Special cups and/or nosepieces may be required (see chart at right).
- Use 8" x 12" Pilot Drill** 05-0293-0012 and **8" x 10/12" Tapping Adapter** 06-6102-0017 when making these reduced branch taps, with 660 or 760 TM.
- Sight Glass Kit** - Requires the use of the 8" T-203 Tapping Adapter. Part No. 06-1544-0000
- Bleeder valve and nipple** are provided with TDW Drilling Machines.
- Fitting** - Leaf-type completion plug and blind flange included.
- 8" Plugging Head Kit** adapts folding head pluggers to plug 8" size-on-size lines and 3-WAY™ Tee Outlet. Kit 08-3420-0000 includes Plugging Head Assembly 08-3320-0000, chip sweep, and adapter.
- With an **8" x 10" Plugging Head Assembly** Nosepiece and Cups, 10" pipe can be plugged. (See 8" x 10" Data Sheet.)
- Sealing Elements** - Refer to chart at right.

Pipe ID	150 psi MWP Sealing Element	150 psi MWP Nosepiece
12.250-12.390	08-2332-0012-00	08-3331-1504
12.062-12.188	08-2332-0012-01	08-3331-1504
11.875-12.000	08-2332-0012-02	08-3331-0004
11.688-11.812	08-2332-0012-03	08-3331-0004

Consult factory for unlisted Pipe ID's.

North & South America: +1 918 447 5000 ■ Europe / Africa / Middle East: +32 67 28 3611 ■ Asia Pacific: +65 6364 8520 ■ www.tdwilliamson.com

Data subject to change without notice. / Dimensions not for construction unless certified. / © Registered trademark of T.D. Williamson in the United States and other countries. / TM Trademark of T.D. Williamson in the United States and other countries. / ©2020 T.D. Williamson



Data Sheet No. **SSII-8x12**

**Fittings**

## **Tapping and *SHORTSTOPP*® II Plugging Machine 8" x 12" Gas Main**

Data Sheet No. **SSII-8x12**



■ **Welding Fitting**  
See Bulletin 2100.003.00



■ **3-WAY™ Tee**  
See Bulletin 2100.002.00



■ **Branch Type II 3-WAY™ Tee**  
See Bulletin 2100.011



■ **Branch Type II Plugging Fitting**  
See Bulletin 2100.010

■ **Note:** Consult your TDW representative for additional fitting options.

North & South America: +1 918 447 5000 ■ Europe / Africa / Middle East: +32 67 28 3611 ■ Asia Pacific: +65 6364 8520 ■ [www.tdwilliamson.com](http://www.tdwilliamson.com)

Data subject to change without notice. / Dimensions not for construction unless certified. / © Registered trademark of T.D. Williamson in the United States and other countries. / TM Trademark of T.D. Williamson in the United States and other countries. / ©2020 T.D. Williamson

Data Sheet No.  
SG 1-1/4-3

# Sight Glass Assembly for 1-1/4" - 3"

Applications 08-3423-0000-SUFFIX



Data Sheet No. SG 1-1/4-3

Date: September 2020

Supersedes: September 2004

Data Sheet No. SG 1-1/4-3

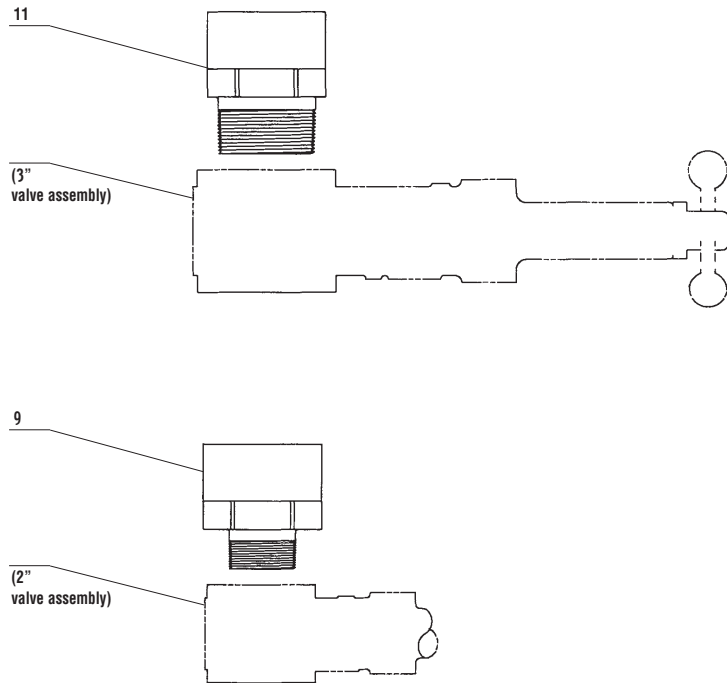
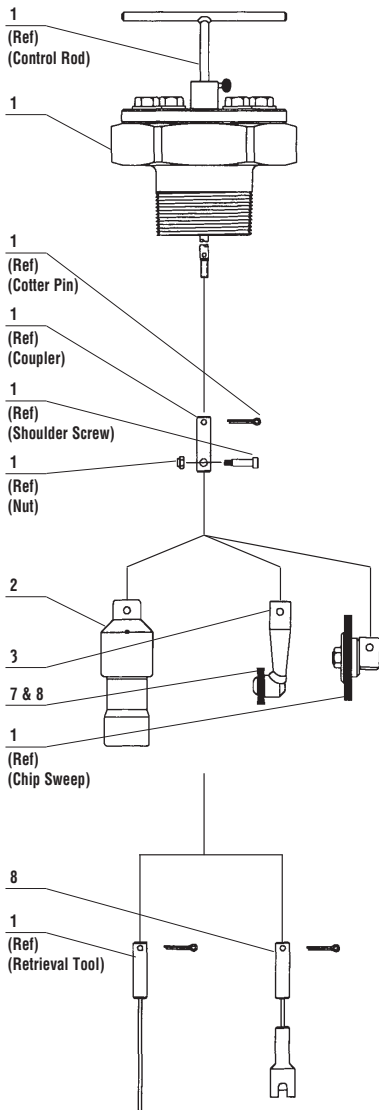

Item	Quantity by Suffix (Note 3)				Description	Part Number
	-03	-02	-01	-00		
1	1	1	1	1	Sight Glass Assembly	08-2340-0000
2	1	1	-	1	Chip Remover Assembly (2" - 4")	08-2341-0000
3	-	-	1	1	Plugging Head (1-1/4")	08-0352-0001-01
6	-	-	1	1	Wire Brush (1-1/4")	00-0025-0061
7	-	-	1	1	Button Head Socket Cap Screw	00-0307-0600-05
8	1	1	1	1	Magnet Assembly	08-3426-0000
9	-	1	1	1	Reducer (3" x 2")	08-2340-0004
11	1	-	-	1	Adapter (3")	08-2340-0005

## Notes

- Maximum Working Pressure: 500 psi at 100°F
- Maximum Working Temperature: 180°F at 440 psi
- Sight Glass Assembly for Inspection/Retrieval with Chip Sweep Only (no magnets) use Item 1, 08-2340-0000. For 2" applications, Item 9 is also required, 08-2340-0004.
- Kit Suffix Number and Pipe Size - Refer to chart at right.
- Cross Indexing Number: SHORTSTOPP® II Bulletin 2080.001.00; T-101 Bulletin 2000.001.00.

Suffix	Nom. Pipe Size
-00	1-1/4" - 3"
-01	1-1/4" - 1-1/2"
-02	2"
-03	3" - 4"

North & South America: +1 918 447 5000 ■ Europe / Africa / Middle East: +32 67 28 3611 ■ Asia Pacific: +65 6364 8520 ■ [www.tdwilliamson.com](http://www.tdwilliamson.com)

Data subject to change without notice. / Dimensions not for construction unless certified. / © Registered trademark of T.D. Williamson in the United States and other countries. / TM Trademark of T.D. Williamson in the United States and other countries. / ©2020 T.D. Williamson

# Sight Glass Assembly for 4" - 12"

**Applications 08-3424-0000-SUFFIX**



Data Sheet No. **SG 4-12**

Date: September 2020

Supersedes: September 2004

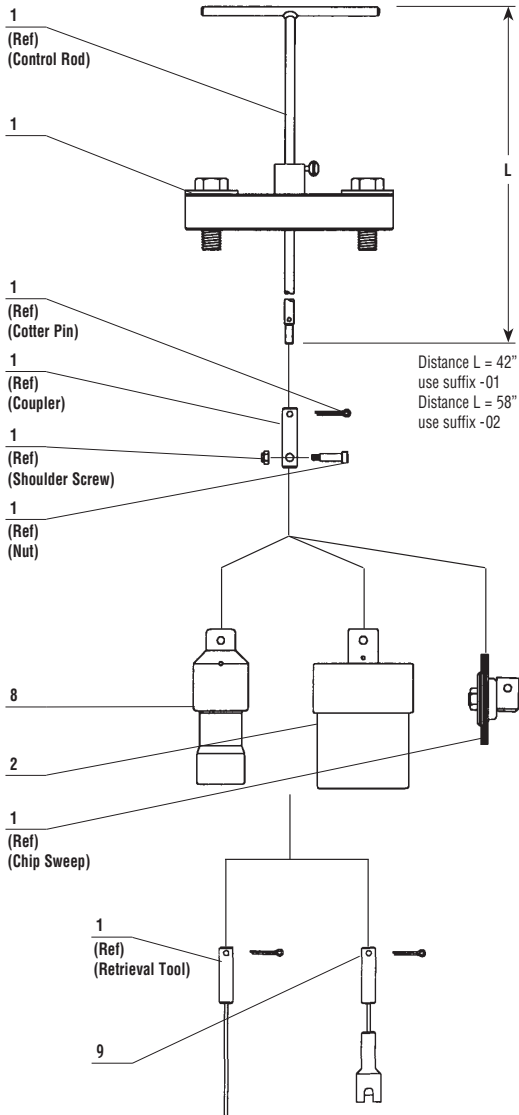

(T-203  
Tapping Adapter)  
(note 5)

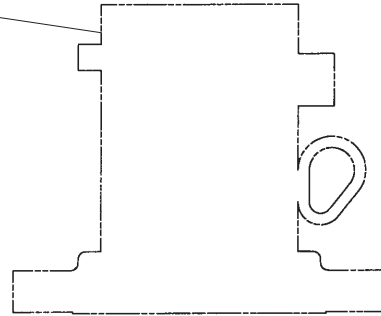

Data Sheet No. **SG 1-1/4-3**

Item	Quantity by Suffix (Note 3)			Description	Part Number
	-02	-01	-00		
1	-	1	-	Sight Glass Assembly (4" - 6")	08-2339-0000-01
1	1	-	1	Sight Glass Assembly (8" - 12")	08-2339-0000-02
2	1	-	1	Chip Remover Assembly (6" - 12")	08-3422-0000
8	-	1	1	Chip Remover (2" - 4")	08-2341-0000
9	1	1	1	Chip Remover (2")	08-3426-0000

## Notes

1. **Maximum Working Pressure:** 500 psi at 100°F
2. **Maximum Working Temperature:** 180°F at 440 psi
3. **Sight Glass Assembly for Inspection/Retrieval with Chip Sweep Only** (no magnets) use Item 1 for appropriate size range shown, 08-2339-0000 SUFF. To cover the complete size range 4"-12", use 08-2339-0000-02
4. Sight Glass requires T-203 Tapping Adapter. (not included)
5. **Kit Suffix Number and Pipe Size** - Refer to chart at right.
6. **Cross Indexing Number:** SHORTSTOPP® II Bulletin 2080.001.00; T-203 Bulletin 2100.007.00.

Suffix	Nom. Pipe Size
-00	4" - 12"
-01	4" - 6"
-02	8" - 12"