



V-Jet® Corrosion Inhibitor Pigs

Sizes: 4- to 28-inch



T.D. Williamson

Bulletin No: **3000.008.01**
Version: 11.2021
Supersedes: 3000.008.00 (03.2008)

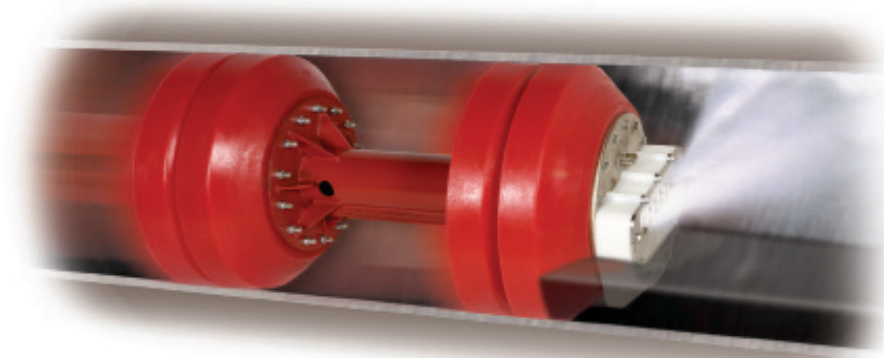

■ **V-Jet® Corrosion Inhibitor Pig**
10- to 28-inch

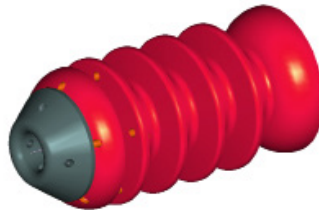

■ **V-Jet® VXP Corrosion Inhibitor Pig**
4- to 8-inch

Description

Injection or batching of corrosion inhibitor fluid can help reduce pipeline deterioration, but gravity naturally forces inhibitor to settle along the bottom of a pipe, leaving the top of the pipe unsaturated and most vulnerable to corrosion. The TDW V-Jet® Corrosion Inhibitor Pig is designed to defy gravity by spraying corrosion inhibitor onto the inside top portion of multi-phase gas gathering or gas transmission pipelines.

The V-Jet Pig works based on the dynamics of bypass flow and differential pressure, with no moving parts or pressure vessels to fill and charge. Instead, the V-Jet Pig's patented design allows the higher pressure to flow through its body and spray head. Bypass flow acts as the accelerant to transfer and vaporize fluid while creating a low pressure area in the spray nozzle as it passes through. This pressure drop creates a vacuum at the V-Jet Pig's front inlet ports, and this vacuum draws up residual corrosion inhibitor that has settled on the bottom of the pipe.

The reclaimed corrosion inhibitor is then redeployed by the nozzles as an atomized spray at about a 45-degree angle (10-inch and larger) onto the top half of the pipe's inner wall. The atomized spray also creates an increasingly dense vapor cloud that is pushed ahead of the V-Jet Pig during the entirety of the run, helping to coat all areas of the pipe wall with inhibitor.

Features

- A counterweight in the V-Jet Pig helps it maintain proper nozzle orientation during each run (10-inch and larger).
- For liquids with physical properties similar to water, each nozzle typically delivers approximately three quarts per minute at 15 psi. Inhibitor delivery rates will vary depending on differential pressure, fluid viscosity and specific gravity.

- Featuring sealing cups molded of tough Formula SI™ urethane, the V-Jet Pig is designed to be sturdy and reliable during long runs.
- The V-Jet Pig works well for the final stages of a cleaning program as a means of removing scale from the pipe's top inner wall.

Options

- The V-Jet Pig is available in multiple sizes and nozzle configurations. For sizes 4- to 8-inch, the V-Jet VXP Pigs have a single central nozzle. Larger diameter V-Jet Pigs are available in a variety of nozzle arrangements, from 10-inch pigs with two nozzles all the way up to 28-inch pigs with nine nozzles. Custom designs are also possible for larger pigs.
- The V-Jet Pig can be used as a stand-alone dewatering pig, or in tandem with a slug of corrosion inhibitor behind. It can also be used in batching mode with a slug of inhibitor separating a batching pig up front and the V-Jet Pig behind. This inhibitor slug serves as a reservoir to supply the V-Jet Pig's spray nozzles and facilitates creation of a dense inhibitor fog between the pigs as they move through the pipe.
- The V-Jet Pig has also been successful in chemical cleaning applications.

V-Jet® Corrosion Inhibitor Pig
Patented in the United States
and in foreign countries.

V-Jet® VXP Corrosion Inhibitor Pig
Patent Pending in the United States
and in foreign countries.

V-Jet® Corrosion Inhibitor Pig

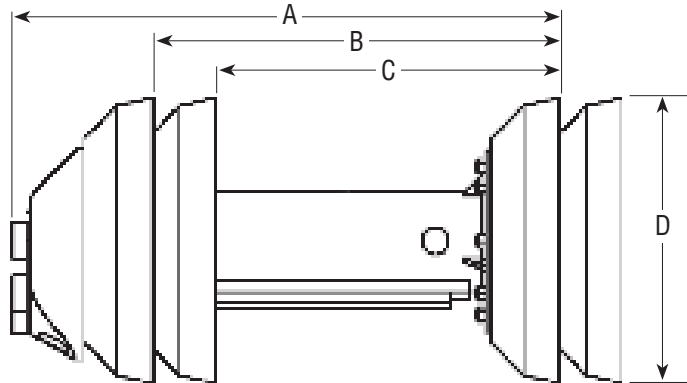

V-Jet® Corrosion Inhibitor Pig - Sizes 10- to 28-inch

Size (Inches)	Part Number	A Inches	B Inches	C Inches	D Inches	Approximate Weight (Lbs.)
10	01-1961-0010-00S	25.68	21.28	18.16	10.62	60
12	01-1961-0012-00S	26.00	21.55	18.36	12.62	75
14	01-1961-0114-00	27.50	22.10	18.35	13.25	105
16	01-1961-0116-00	34.06	28.18	24.68	15.88	130
18	01-1961-0018-00	38.00	32.00	28.00	17.88	182
20	01-1961-0020-00	39.00	32.00	28.25	19.88	210
22	01-1961-0022-00	45.20	38.50	33.88	22.00	273
24	01-1961-0024-00	46.50	38.75	34.12	24.00	315
26	01-1961-0026-00	53.81	45.63	40.50	26.00	497
28	01-1961-0028-00	55.44	45.88	40.75	28.00	566

V-Jet® VXP Corrosion Inhibitor Pig Part Number System:

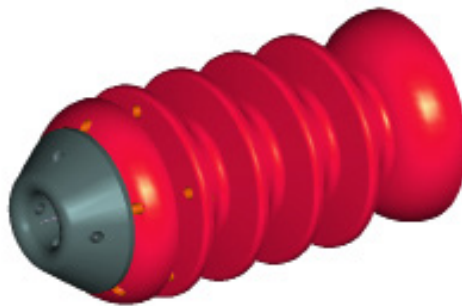
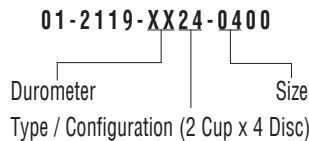

V-Jet® VXP Corrosion Inhibitor Pig - Sizes 4- to 8-inch

Size (Inches)	Part Number	A Inches	B Inches	D Inches	Approximate Weight (Lbs.)
4	01-2119-XX24-0400	8.76	6.98	4.38	2.3
6	01-2119-XX24-0600	14.15	11.75	6.50	6
8	01-2119-XX24-0800	17.50	14.07	8.50	12