

Tapping and SHORTSTOPP® Plugging Machine

Equipment Needed to Plug a 1-1/2" Gas Main to 285 psi



T.D. Williamson, Inc.

Data Sheet No. SS275-1-1/2

Date: May 2004

Supersedes: January 2003

Tapping

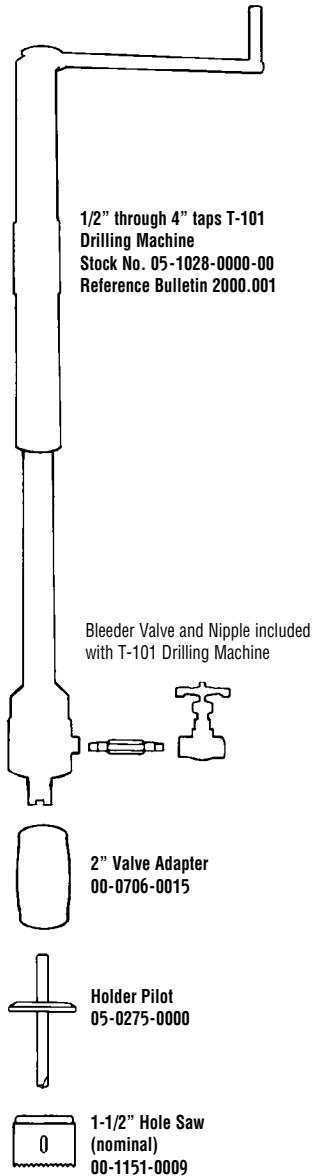

Plugging

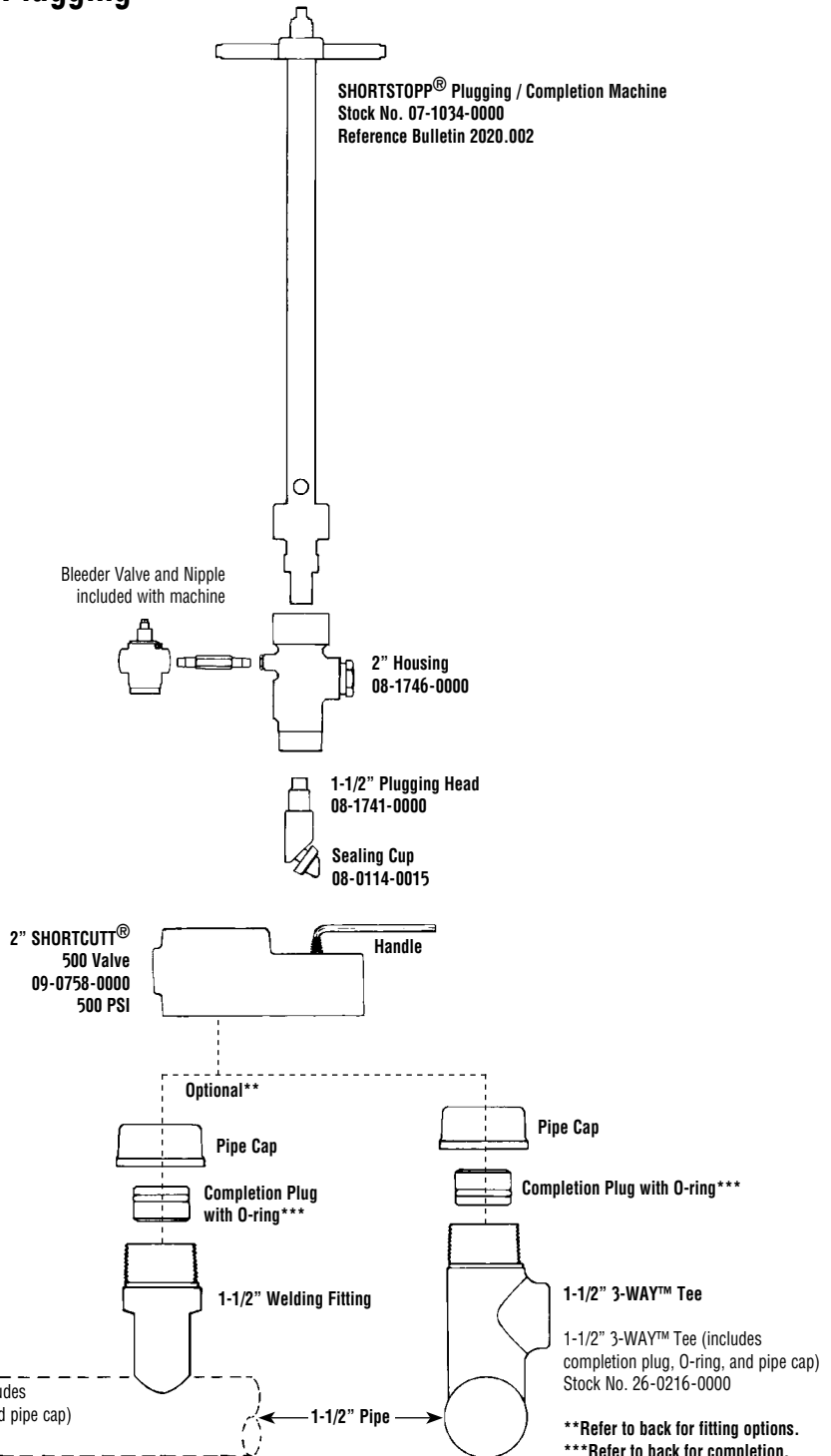

Data Sheet No. SS275-1-1/5



T.D. Williamson, Inc.

Data Sheet No. **SS275-1-1/2**

Fittings

Tapping and **SHORTSTOPP®** Plugging Machine

1-1/2" Gas Main to 275 psi

Data Sheet No. **SS275-1-1/2**



■ **Welding Fitting**
See Bulletin 2100.003



■ **3-WAY™ Tee**
See Bulletin 2100.002

■ Note: Consult your TDW representative for additional fitting options.

Completion

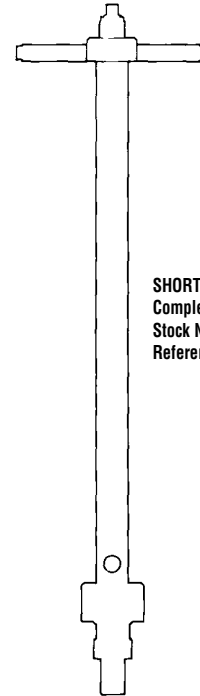

SHORTSTOPP® Plugging/
Completion Machine
Stock No. 07-1034-0000
Reference Bulletin 2020.002

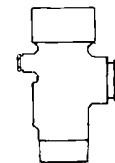

2" Housing
08-1746-0000



Completion Plug Holder
07-0974-0000

Tapping and SHORTSTOPP® Plugging Machine

Equipment Needed to Plug a 2" Gas Main to 285 psi



T.D. Williamson, Inc.

Data Sheet No. **SS275-2**

Date: January 2003

Supersedes: March 1999

Tapping

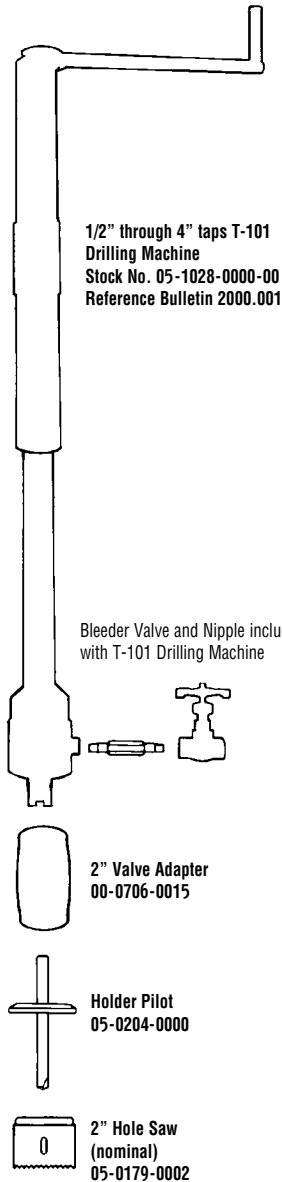

Plugging

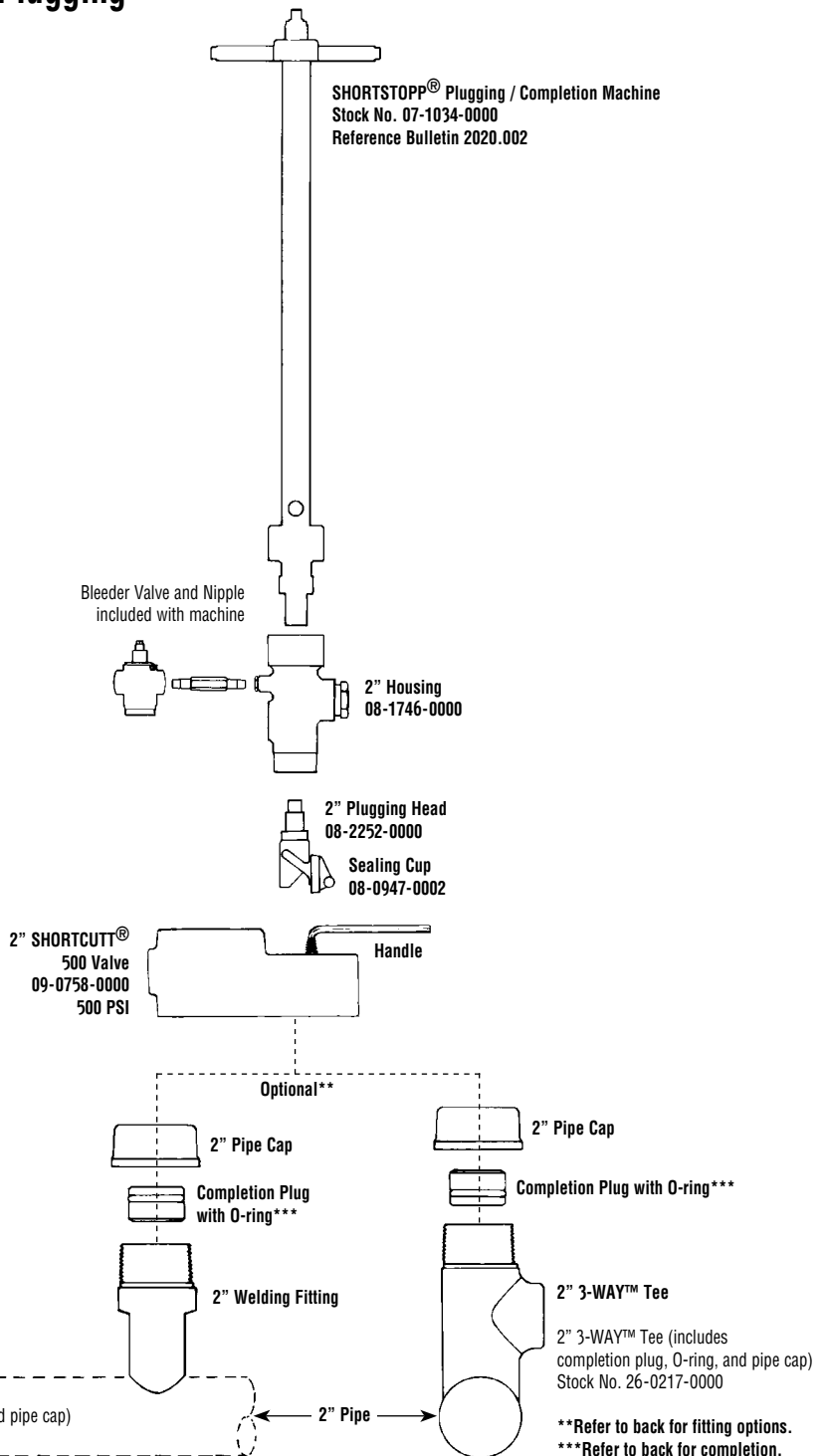



T.D. Williamson, Inc.

Data Sheet No. **SS275-2**

Fittings

Tapping and **SHORTSTOPP®** Plugging Machine 2" Gas Main to 285 psi



■ **Welding Fitting**
See Bulletin 2100.003



■ **Spherical 3-WAY™ Tee**
See Bulletin 2100.007



■ **3-WAY™ Tee**
See Bulletin 2100.002



■ **Mechanical SHORTSLEEVE™ Fitting**
See Bulletin 2110.002

■ Note: Consult your TDW representative for additional fitting options.

Completion

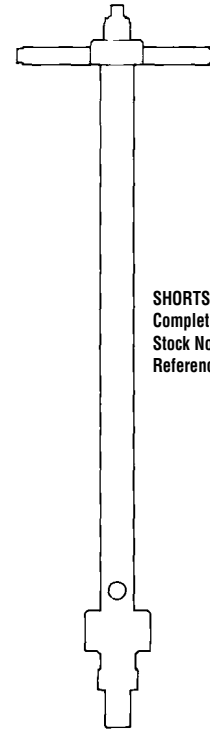

**SHORTSTOPP® Plugging/
Completion Machine**
Stock No. 07-1034-0000
Reference Bulletin 2020.002

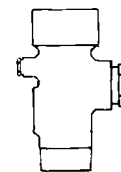

2" Housing
08-1746-0000



Completion Plug Holder
07-0974-0000

Data Sheet No. **SS275-2**

Tapping and SHORTSTOPP® Plugging Machine

Equipment Needed to Plug a 3" Gas Main to 285 psi



T.D. Williamson, Inc.

Data Sheet No. **SS275-3**

Date: January 2003

Supersedes: March 1999

Tapping

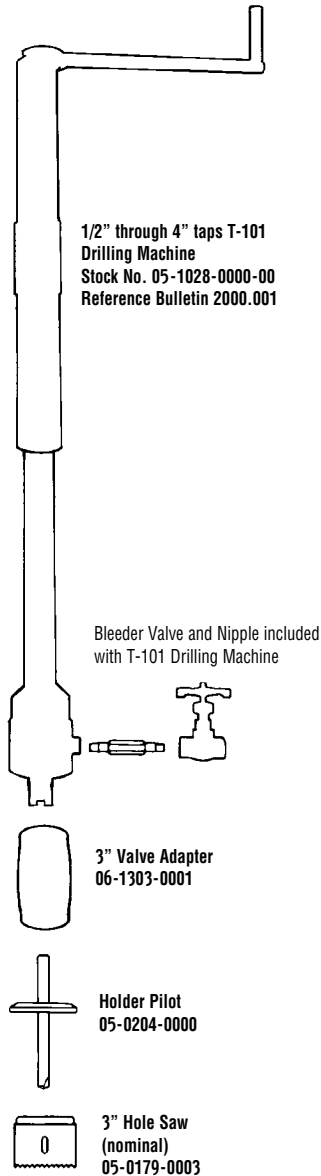

Plugging

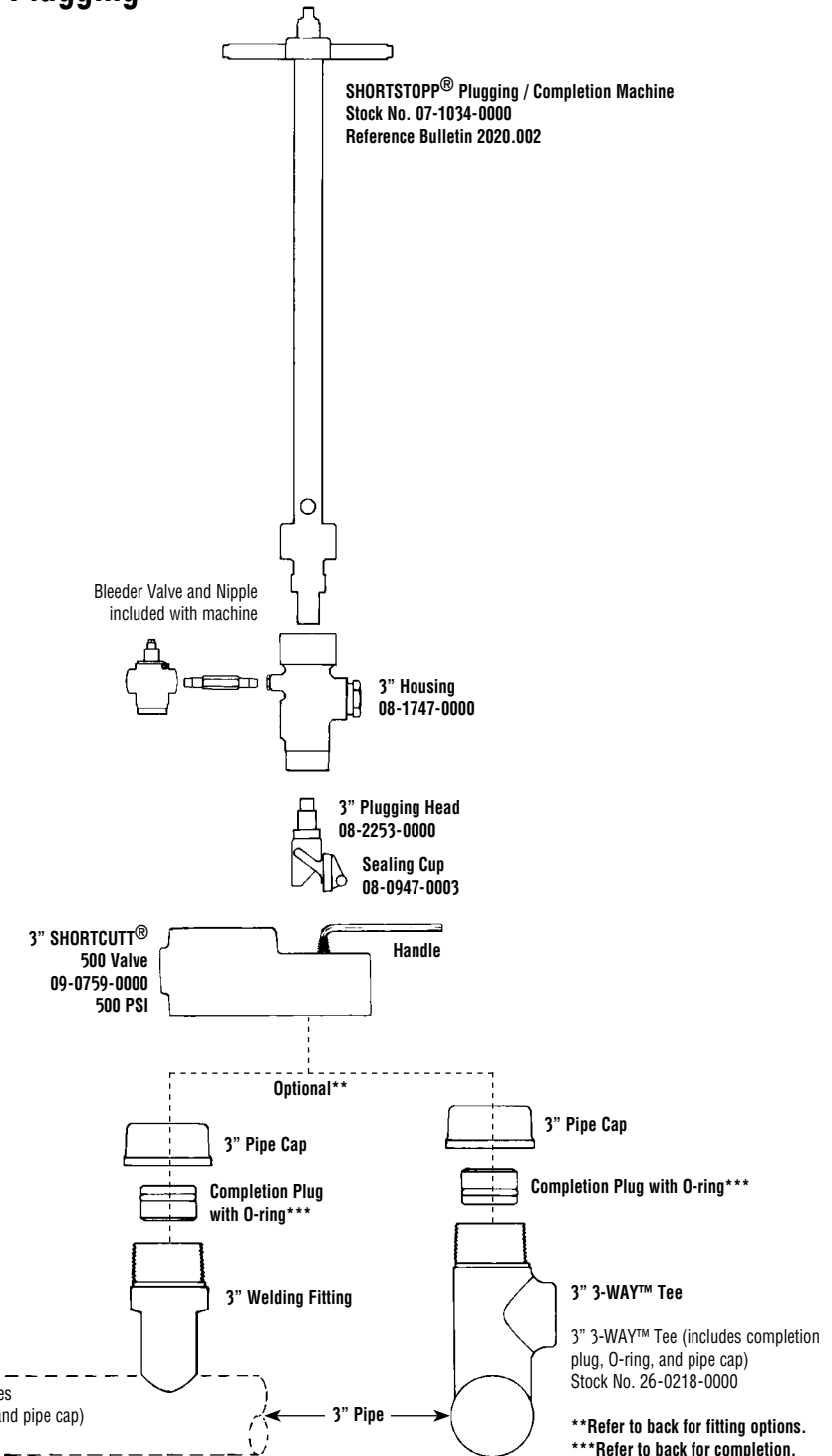



T.D. Williamson, Inc.

Data Sheet No. **SS275-3**

Fittings

Tapping and **SHORTSTOPP®** Plugging Machine 3" Gas Main to 285 psi

Data Sheet No. **SS275-3**



■ **Welding Fitting**
See Bulletin 2100.003



■ **Spherical 3-WAY™ Tee**
See Bulletin 2100.007



■ **3-WAY™ Tee**
See Bulletin 2100.002

■ **Note:** Consult your TDW representative for additional fitting options.

Completion

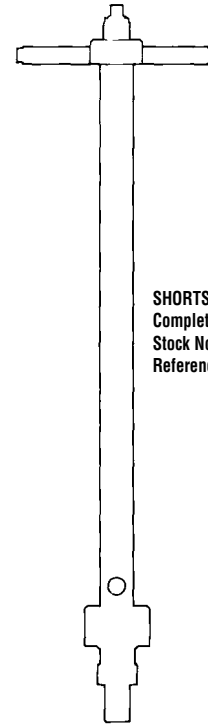

SHORTSTOPP® Plugging/
Completion Machine
Stock No. 07-1034-0000
Reference Bulletin 2020.002

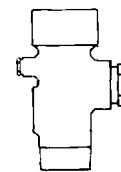

3" Housing
08-1747-0000



Completion Plug Holder
07-0974-0000

Tapping and SHORTSTOPP® Plugging Machine

*Equipment Needed to Plug a 4" Gas Main to 285 psi
Using Completion Machine*



T.D. Williamson, Inc.

Data Sheet No. **SS275-4**

Date: September 2004

Supersedes: January 2003

Tapping

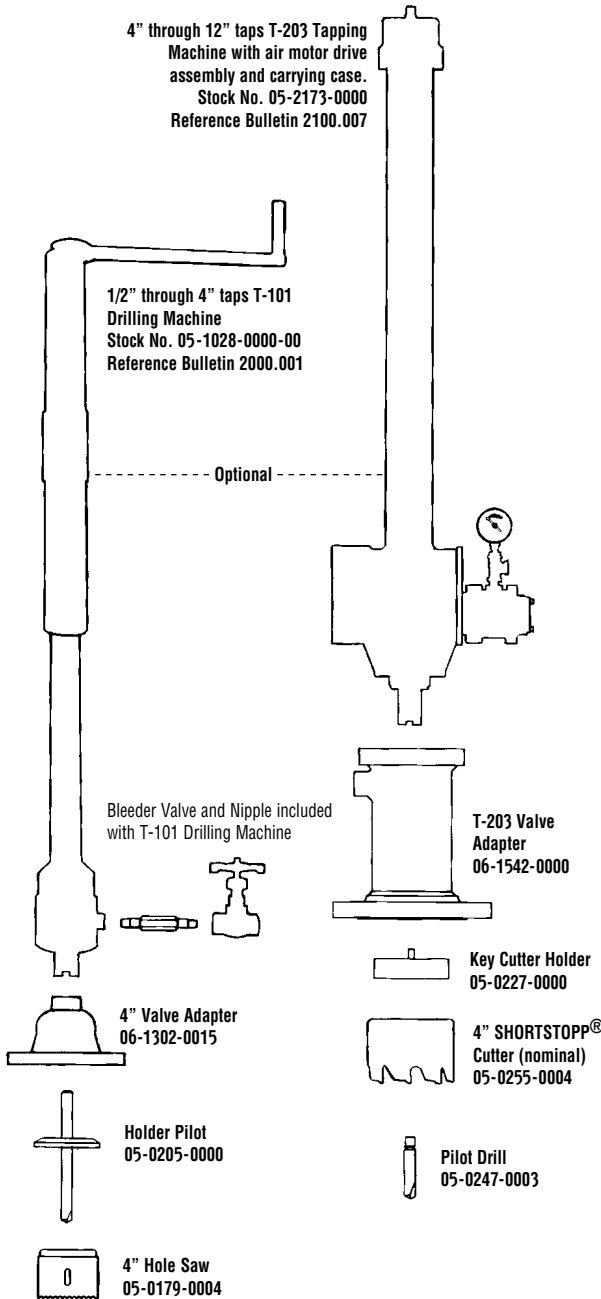

Plugging

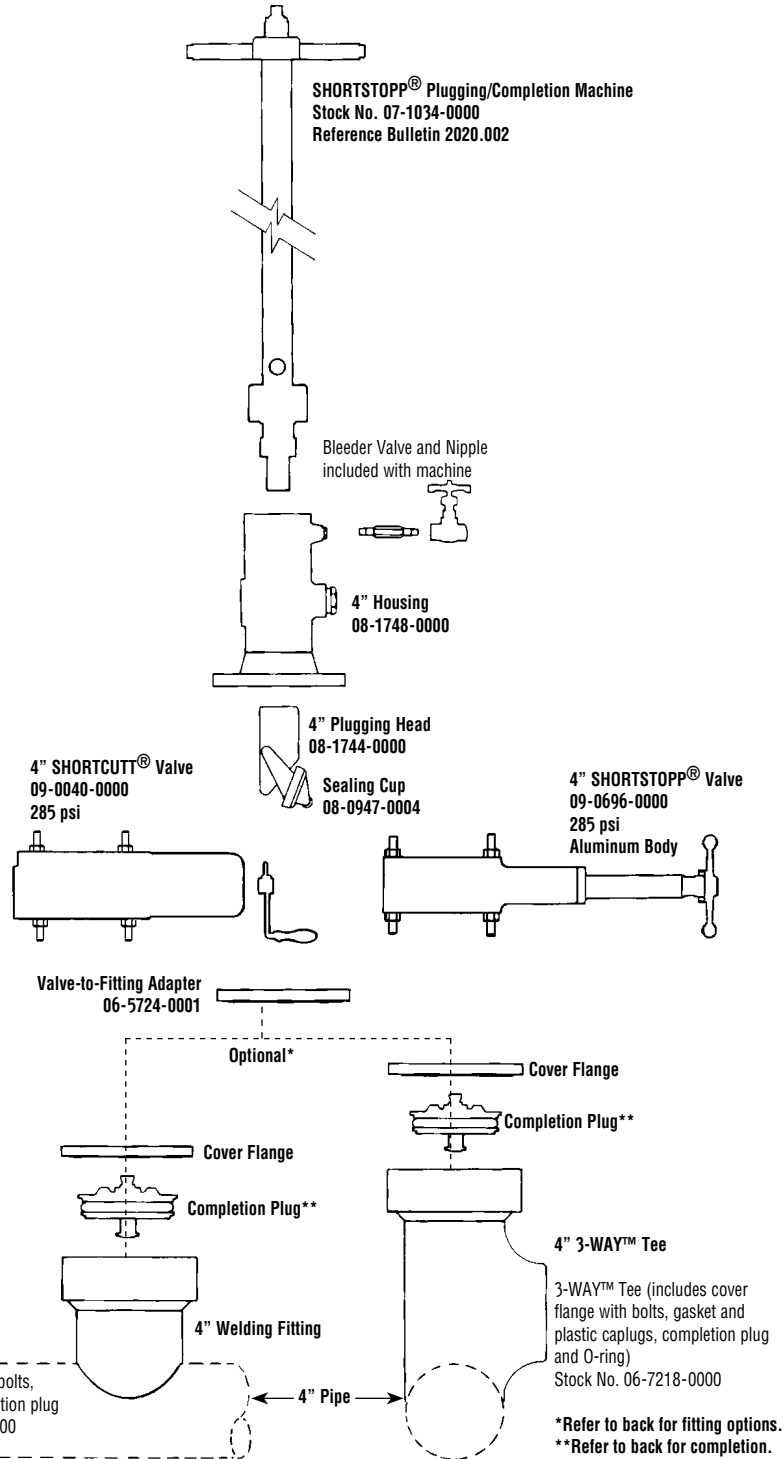

Data Sheet No. SS275-4



T.D. Williamson, Inc.

Data Sheet No. **SS275-4**

Fittings

Tapping and **SHORTSTOPP**® Plugging Machine 4" Gas Main to 285 psi

Data Sheet No. **SS275-4**



Optional



■ **Welding Fitting and SHORTPLUG™ with Guide Bars**
See Bulletin 2100.013

■ **Welding Fitting**
See Bulletin 2100.003



Optional



■ **Spherical 3-WAY™ Tee and SHORTPLUG™ with Guide Bars**
See Bulletin 2100.014

■ **Spherical 3-WAY™ Tee**
See Bulletin 2100.007



Optional



■ **3-WAY™ Tee and SHORTPLUG™ with Guide Bars**
See Bulletin 2100.012

■ **3-WAY™ Tee**
See Bulletin 2100.002



■ **Mechanical SHORTSLEEVE™ Fitting**
See Bulletin 2110.001

■ **Note:** Consult your TDW representative for additional fitting options.

Completion

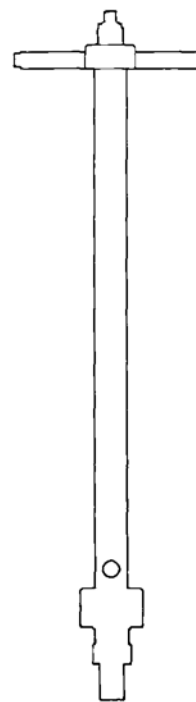

SHORTSTOPP® Plugging/Completion Machine
Stock No. 07-1034-0000
Reference Bulletin 2020.002.00

Optional*

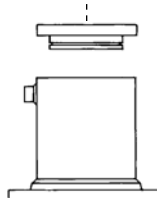

Plate Adapter
06-7265-0000



T-203 Tapping Adapter
06-1542-0000



4" Spool Adapter
06-1165-0176
(Note 1)



4" Housing
08-1748-0000



4" Spool Adapter
06-1165-0176
(Note 2)



Completion Plug Holder
07-0334-0000



Completion Plug Holder
07-0334-0000

■ **Note 1:** 4-inch Spool Adapter required to set 4-inch SHORTPLUG™ with Guide Bars in all SHORTSTOPP Type II fittings using the 06-1542-0000 T-203 Tapping Adapter.

■ **Note 2:** 4-inch Spool Adapter required to set 4-inch SHORTPLUG™ with Guide Bars in SHORTSTOPP Type II 3-Way™ Tee fittings using the 08-1748-0000 4-inch Housing.

Tapping and SHORTSTOPP® Plugging Machine

Equipment Needed to Plug a 4" Gas Main to 285 psi



T.D. Williamson, Inc.

Data Sheet No. **SS275-4A**

Date: September 2004

Supersedes: January 2003

Data Sheet No. SS275-4A

Tapping

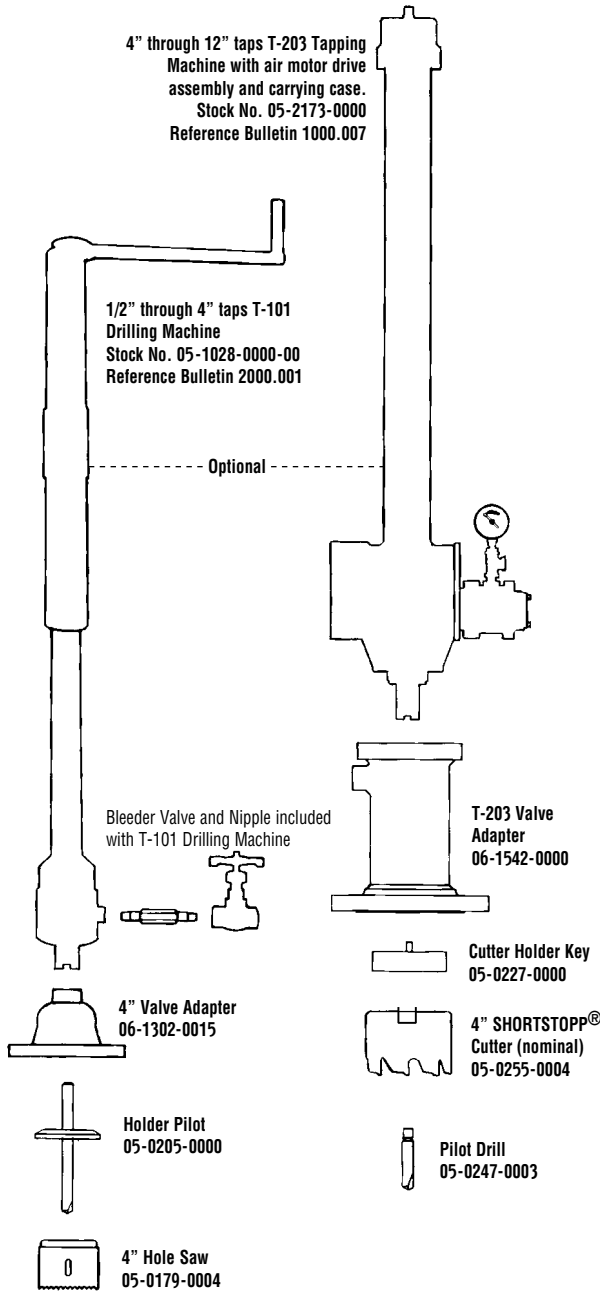

Plugging

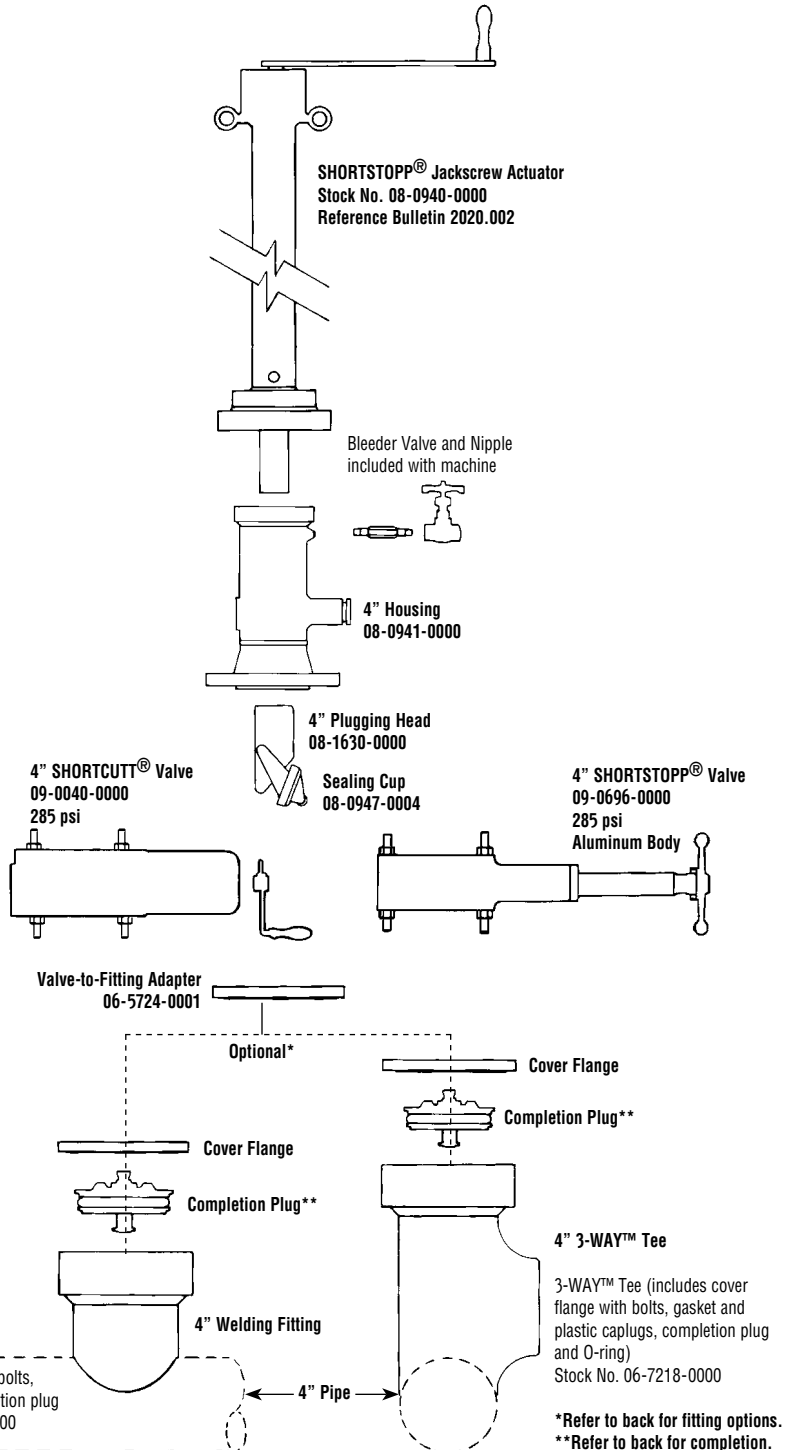



T.D. Williamson, Inc.

Data Sheet No. **SS275-4A**

Fittings

Tapping and **SHORTSTOPP**® Plugging Machine

4" Gas Main to 285 psi

Data Sheet No. **SS275-4A**

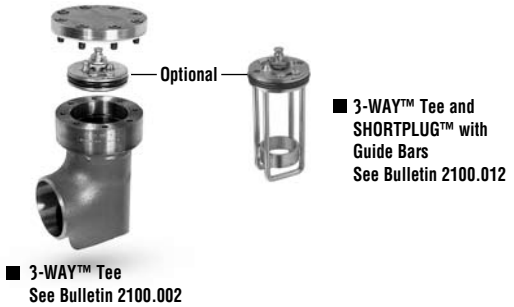
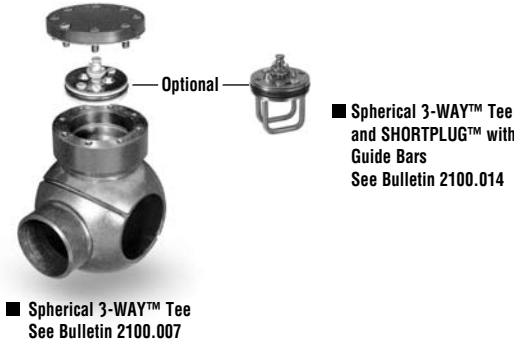
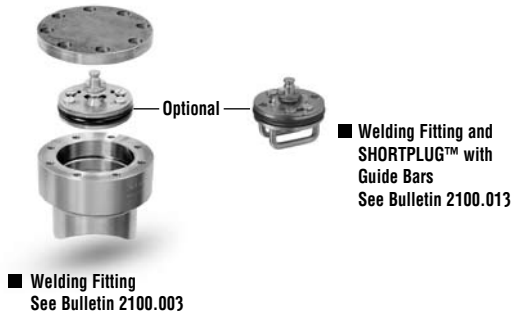

■ Note: Consult your TDW representative for additional fitting options.

Completion

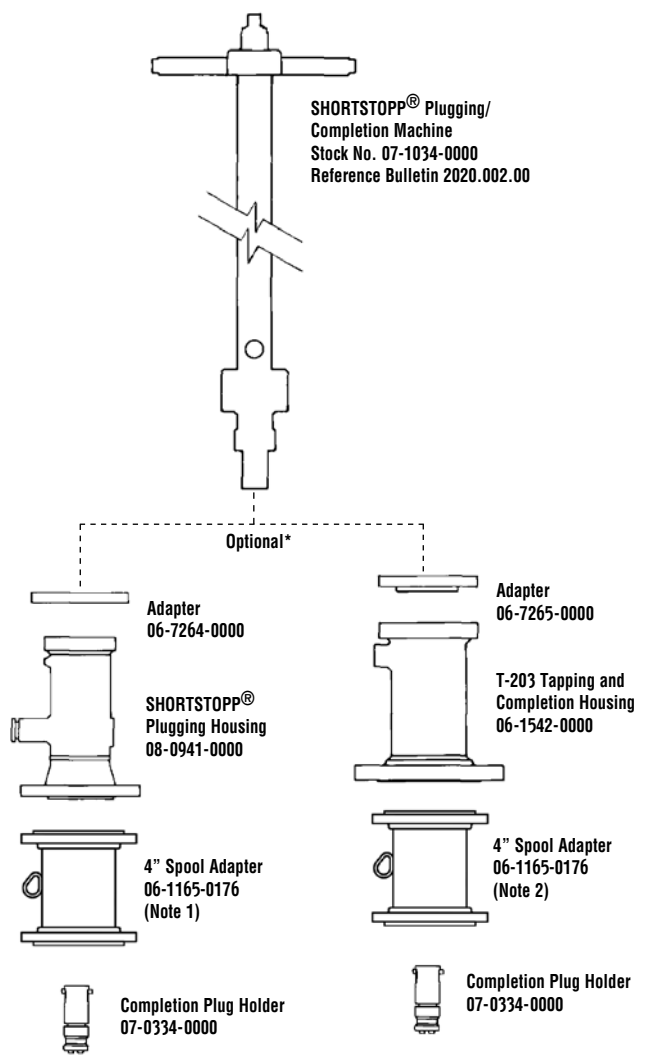

- Note 1: 4-inch Spool Adapter required to set 4-inch SHORTPLUG™ with Guide Bars in SHORTSTOPP 3-Way™ Tee Type II fittings using the 08-0941-0000 Housing.
- Note 2: 4-inch Spool Adapter required to set 4-inch SHORTPLUG™ with Guide Bars in all SHORTSTOPP Type II fittings using the 06-1542-0000 Adapter

Tapping and SHORTSTOPP® Plugging Machine

Equipment Needed to Plug a 6" Gas Main to 285 psi



T.D. Williamson, Inc.

Data Sheet No. **SS275-6**

Date: September 2004

Supersedes: January 2003

Data Sheet No. SS275-6

Tapping

■ Note: Either the T-101 XL or T-203 Tapping Machine is recommended for 6" taps.

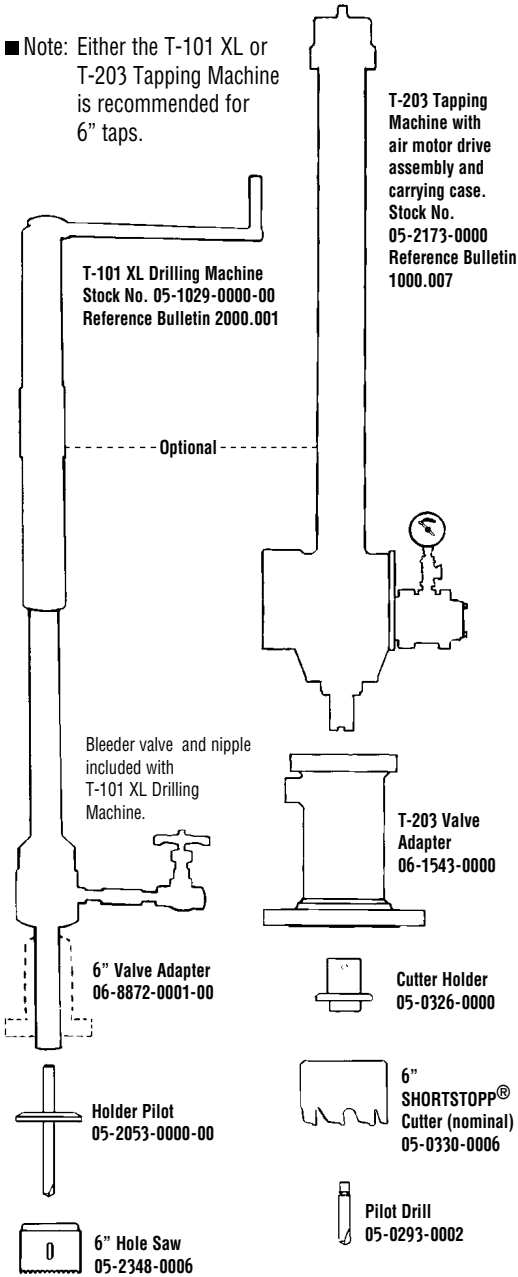

Plugging

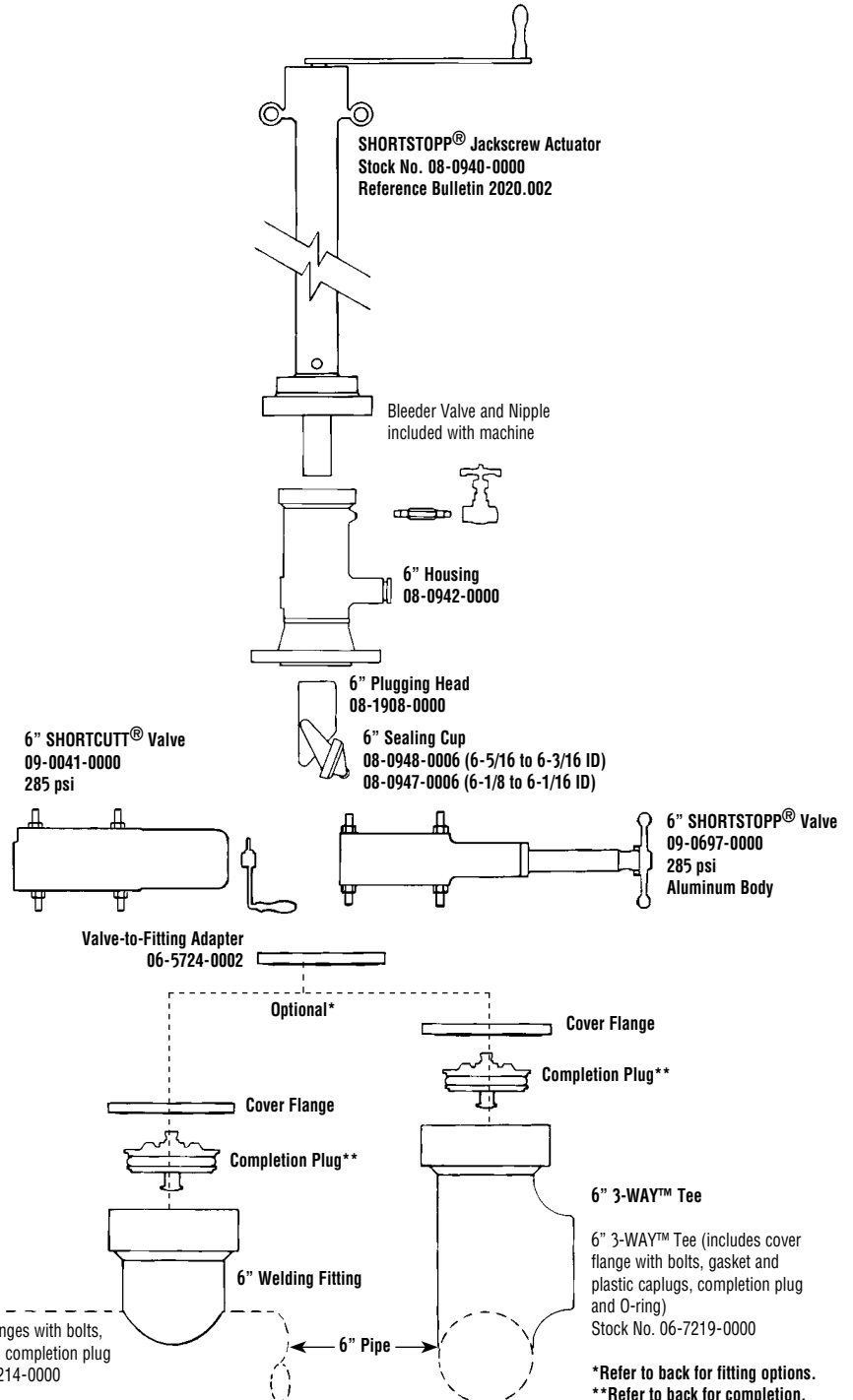



T.D. Williamson, Inc.

Data Sheet No. **SS275-6**

Fittings

Tapping and **SHORTSTOPP®** Plugging Machine

6" Gas Main to 285 psi

Data Sheet No. **SS275-6**

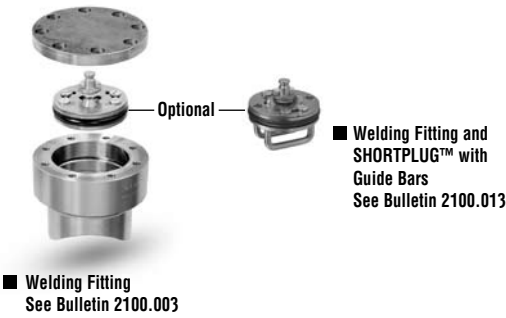

■ Note: Consult your TDW representative for additional fitting options.

Completion

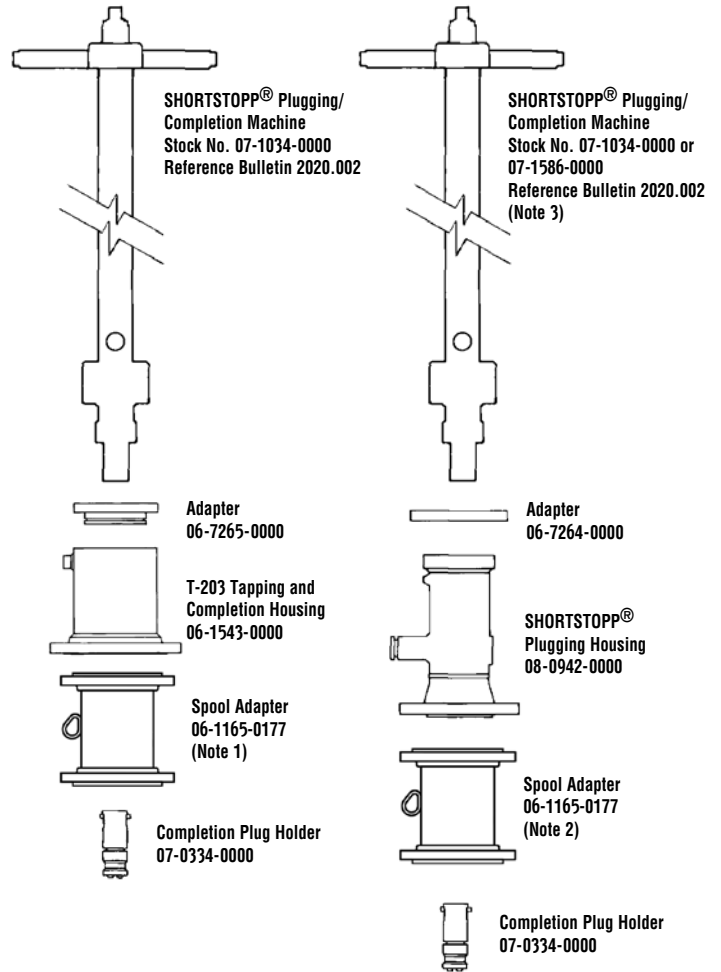

- Note 1: 6-inch Spool Adapter required to set 6-inch SHORTPLUG™ with Guide Bars in SHORTSTOPP Type II 3-Way™ Tee and Spherical fittings using the 06-1543-0000 Adapter.
- Note 2: 6-inch Spool Adapter required to set 6-inch SHORTPLUG™ with Guide Bars in SHORTSTOPP Type II 3-Way™ Tee fittings using the 08-0942-0000 Housing. Also must use the 07-1586-0000 Completion Machine with 48-inch travel.
- Note 3: The 07-1586-0000 Completion Machine with 48" travel is required to set 6" SHORTPLUG™ with Guide Bars in SHORTSTOPP Type II fittings using the 08-0942-0000 Adapter.

Tapping and SHORTSTOPP® Plugging Machine

Equipment Needed to Plug a 8" Gas Main to 285 psi



T.D. Williamson, Inc.

Data Sheet No. **SS275-8**

Date: September 2004

Supersedes: January 2003

Tapping

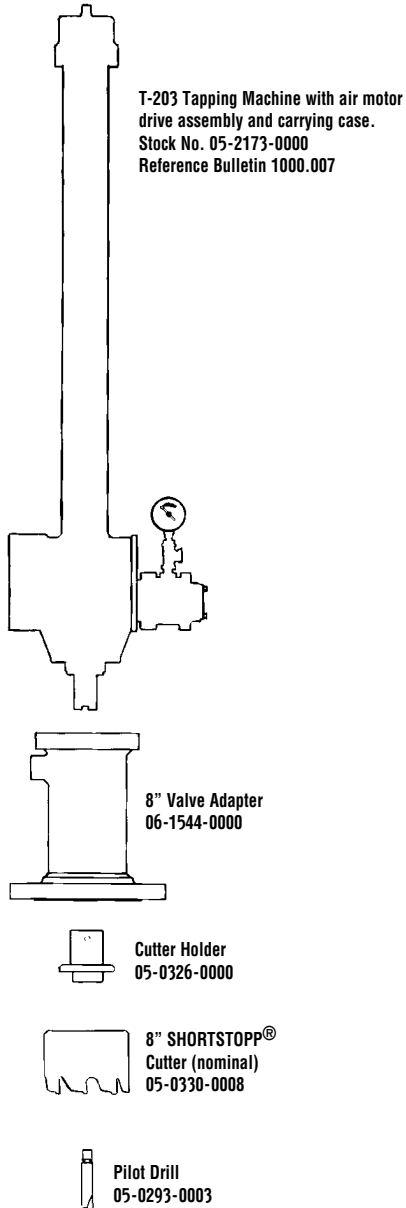

Plugging

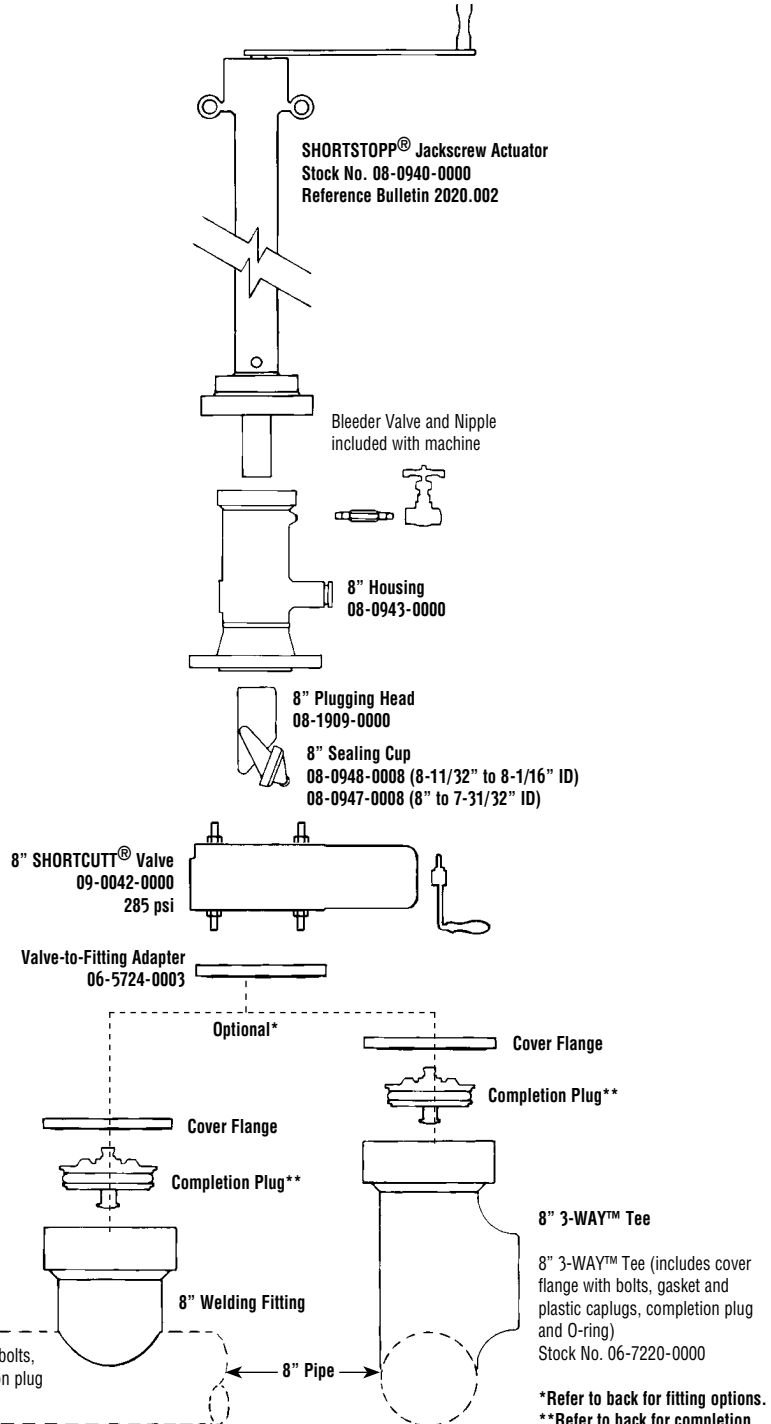



T.D. Williamson, Inc.

Data Sheet No. **SS275-8**

Fittings

Tapping and **SHORTSTOPP**® Plugging Machine

8" Gas Main to 285 psi

Data Sheet No. **SS275-8**

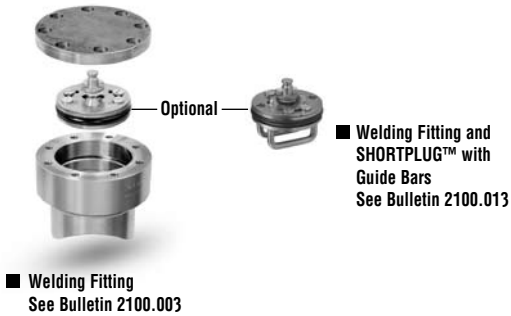

Completion

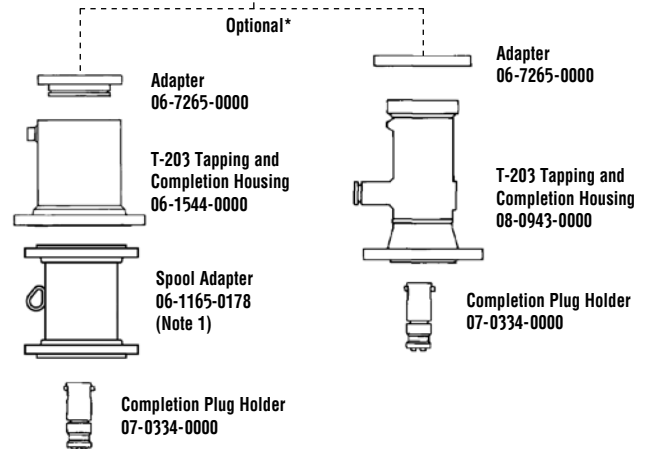
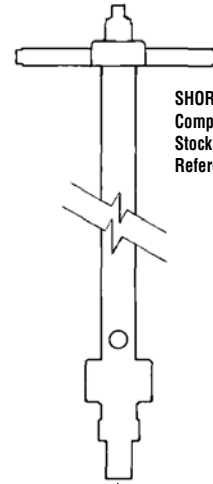

■ Note 1: 8-inch Spool Adapter required to set 8-inch SHORTPLUG™ with Guide Bars in SHORTSTOPP Type II 3-Way™ Tee fittings using the 06-1544-0000 Adapter.

■ Note: Consult your TDW representative for additional fitting options.

Tapping and SHORTSTOPP® Plugging Machine

Equipment Needed to Plug a 10" Gas Main to 285 psi



T.D. Williamson, Inc.

Data Sheet No. **SS275-10**

Date: September 2004

Supersedes: January 2003

Tapping

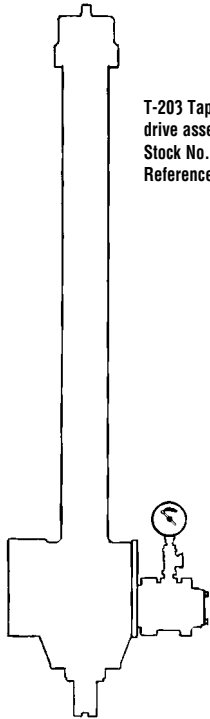

T-203 Tapping Machine with air motor drive assembly and carrying case.
Stock No. 05-2173-0000
Reference Bulletin 1000.007

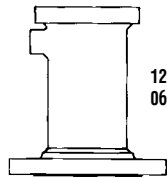

12" Valve Adapter
06-1546-0000



Cutter Holder
05-0326-0000



10" SHORTSTOPP®
Cutter (nominal)
05-0330-0010



Pilot Drill
05-0293-0004

Plugging

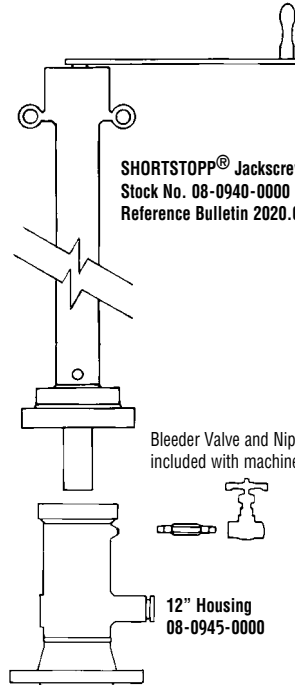

SHORTSTOPP® Jackscrew Actuator
Stock No. 08-0940-0000
Reference Bulletin 2020.002

Bleeder Valve and Nipple
included with machine

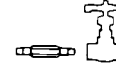

12" Housing
08-0945-0000

10" Plugging Head
08-1910-0000

10" Sealing Cup
08-0948-0010 (10-3/8" to 10-3/16" ID)
08-0947-0010 (10-1/8" to 10-1/64" ID)

12" SHORTCUTT® Valve
09-0044-0000
285 psi

Valve-to-Fitting Adapter
06-5724-0012

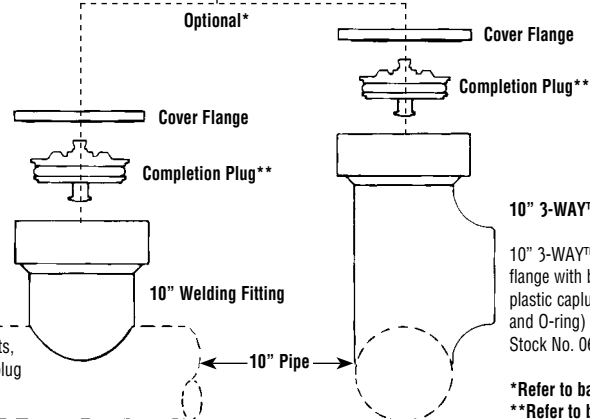

10" fitting (includes cover flange with bolts, gaskets and plastic caplugs, completion plug and O-ring) Stock No. 06-7216-0000

*Refer to back for fitting options.
**Refer to back for completion.



T.D. Williamson, Inc.

Data Sheet No. **SS275-10**

Fittings

Tapping and **SHORTSTOPP®** Plugging Machine 10" Gas Main to 285 psi

Data Sheet No. **SS275-10**

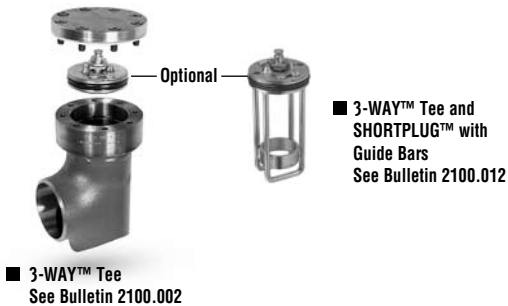
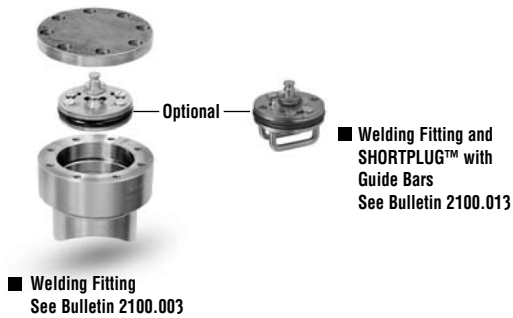

Completion

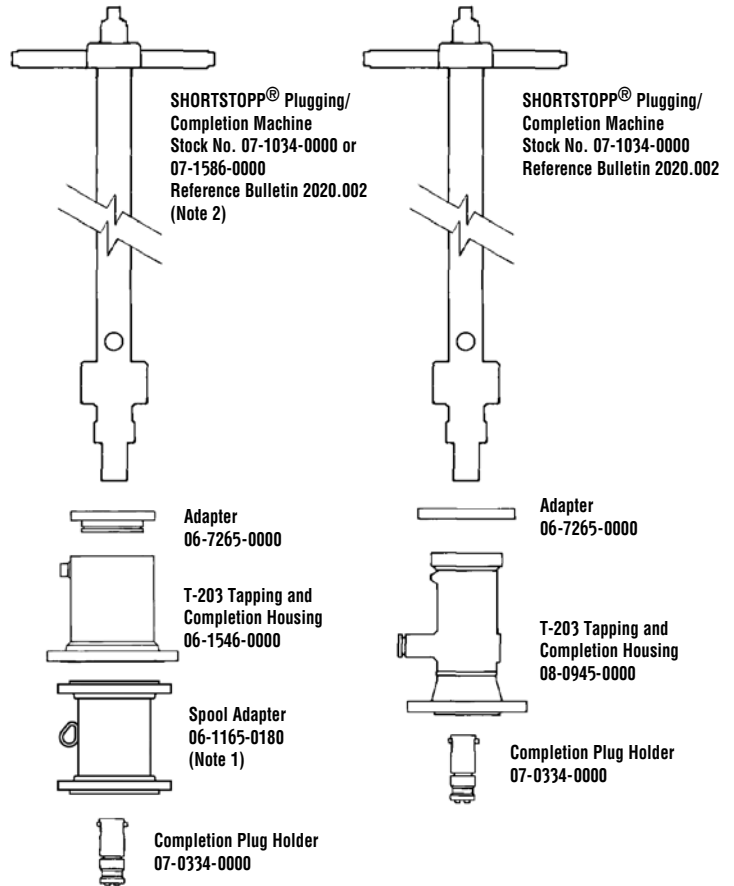

■ Note 1: 12-inch Spool Adapter required to set 10-inch **SHORTPLUG™** with Guide Bars in **SHORTSTOPP** Type II 3-Way™ Tee fittings using the 06-1546-0000 Adapter and 07-1586-0000 Completion Machine

Note 2: The 07-1586-0000 Completion Machine with 48" travel is required to set 10" **SHORTPLUG™** with Guide Bars in **SHORTSTOPP** Type II 3-Way™ Tee fittings using the 06-1546-0000 Adapter.

■ Note: Consult your TDW representative for additional fitting options.

Tapping and SHORTSTOPP® Plugging Machine

Equipment Needed to Plug a 12" Gas Main to 285 psi



T.D. Williamson, Inc.

Data Sheet No. **SS275-12**

Date: September 2004

Supersedes: January 2003

Tapping

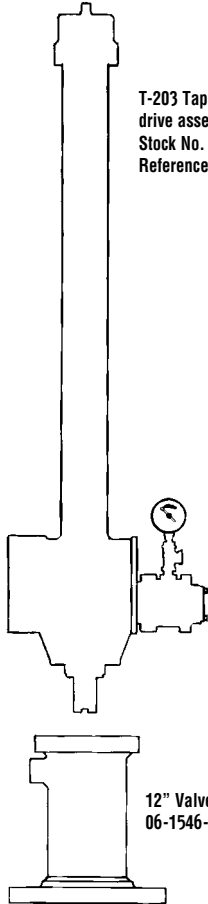

T-203 Tapping Machine with air motor drive assembly and carrying case.
Stock No. 05-2173-0000
Reference Bulletin 1000.007

12" Valve Adapter
06-1546-0000

Cutter Holder
05-0326-0000

12" SHORTSTOPP®
Cutter (nominal)
05-0330-0012

Pilot Drill
05-0293-0005

Plugging

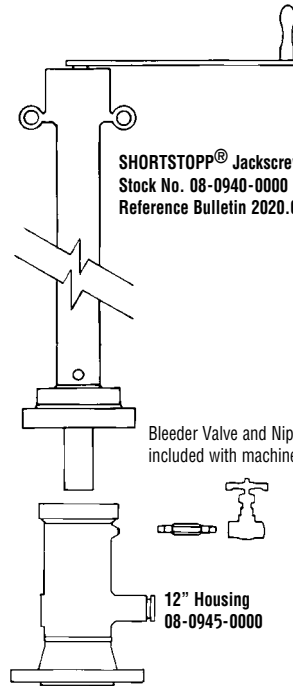

SHORTSTOPP® Jackscrew Actuator
Stock No. 08-0940-0000
Reference Bulletin 2020.002

Bleeder Valve and Nipple
included with machine

12" Housing
08-0945-0000

12" Plugging Head
08-1911-0000

12" Sealing Cup
08-0947-0012 (12-11/32 to 11-15/16 ID)

12" SHORTCUTT® Valve
09-0044-0000
285 psi

Valve-to-Fitting Adapter
06-5724-0011

When a 12" SHORTCUTT® Valve is used on a 10" fitting, it will require a 06-5724-0012 Valve-to-Fitting Adapter.

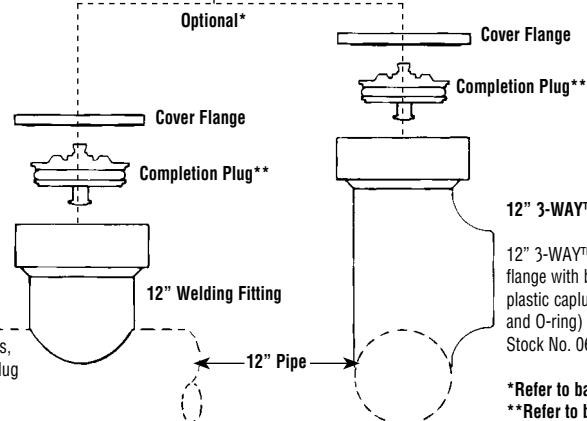

12" fitting (includes cover flange with bolts, gaskets and plastic caplugs, completion plug and O-ring) Stock No. 06-7217-0000

12" 3-WAY™ Tee
12" 3-WAY™ Tee (includes cover flange with bolts, gasket and plastic caplugs, completion plug and O-ring)
Stock No. 06-7222-0000

*Refer to back for fitting options.
**Refer to back for completion.



T.D. Williamson, Inc.

Data Sheet No. **SS275-12**

Fittings

Tapping and **SHORTSTOPP**® Plugging Machine

12" Gas Main to 285 psi

Data Sheet No. **SS275-12**

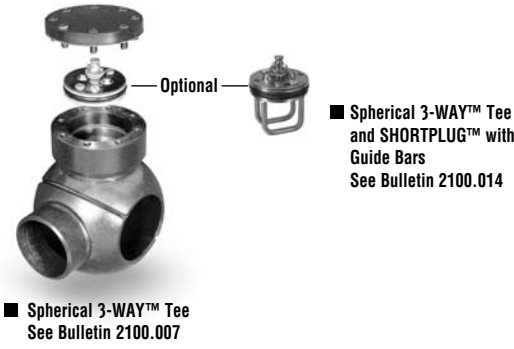
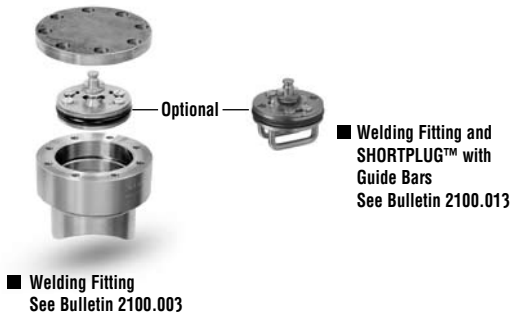

■ Note: Consult your TDW representative for additional fitting options.

Completion

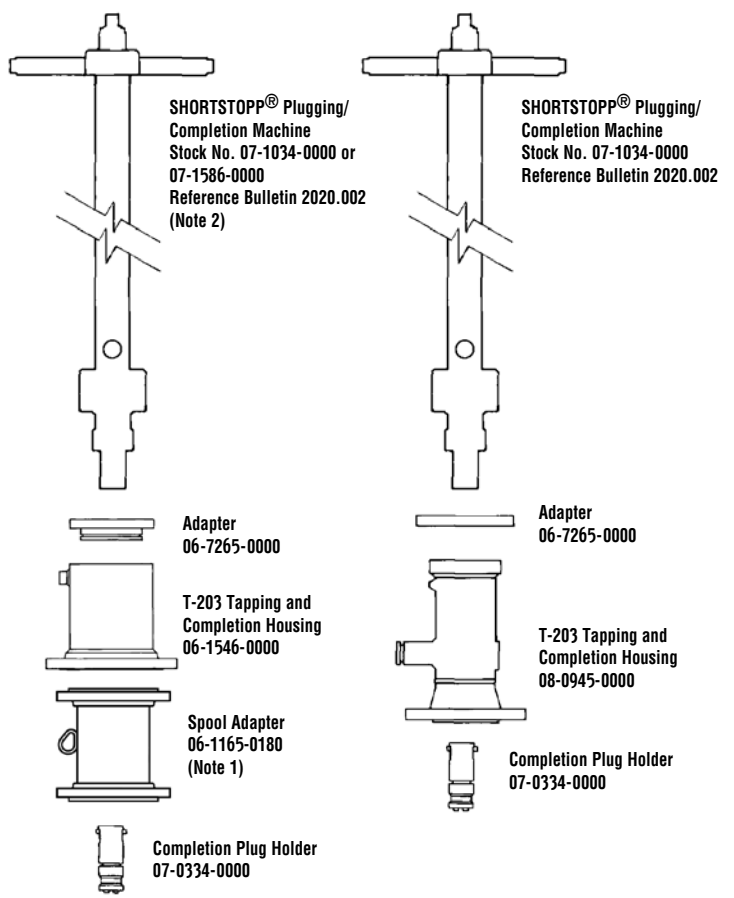

- Note 1: 12-inch Spool Adapter required to set 12-inch SHORTPLUG™ with Guide Bars in SHORTSTOPP Type II 3-Way™ Tee fittings using the 06-1546-0000 Adapter and 07-1586-0000 Completion Machine
- Note 2: The 07-1586-0000 Completion Machine with 48" travel is required to set 12" SHORTPLUG™ with Guide Bars in SHORTSTOPP Type II 3-Way™ Tee fittings using the 06-1546-0000 Adapter.