



TDW Tapping Fittings

Sizes: 2- through 30-inch



T.D. Williamson

Bulletin No: 1110.001.05

Version: 04.2009

Cross Indexing No: n/a

Supersedes: 1110.001.04 (06.2005)



■ Size-on-Size Tapping Fitting

■ Reduced Branch Tapping Fitting

Description

Tapping Fittings are full-branch or reducing-branch split tees designed for use when installing branch lines. They are equipped with ASME Class 150, 300, 600. RF or RTJ flanges.

Features

Flange-to-sleeve weld joints and sleeves are designed to meet pressure and reinforcement requirements of ASME codes, and are available in Class 150, 300 and 600. Other ASME Class ratings available upon request.

Fittings are manufactured with a controlled carbon equivalent to make welding easier in harsh outside environments.

All pressure-containing welds on the fittings have undergone X-ray inspection per ASME requirements.

Fitting sleeves are an extruded type design. They are manufactured from a pressure-vessel quality, normalized, killed carbon steel plate with hardness below Rc22.

The Charpy impact value of the sleeves at -50°F is available on request.

Options

Use the grid inside to develop the part number for the tapping fitting of your choice.*

If the desired fitting meets standard specifications, it can be shipped from stock within two weeks in most cases.

Contact the factory for information concerning ordering of split sleeves (tees).

*Please confirm your choice with a Factory Representative

Typical Tapping Setup

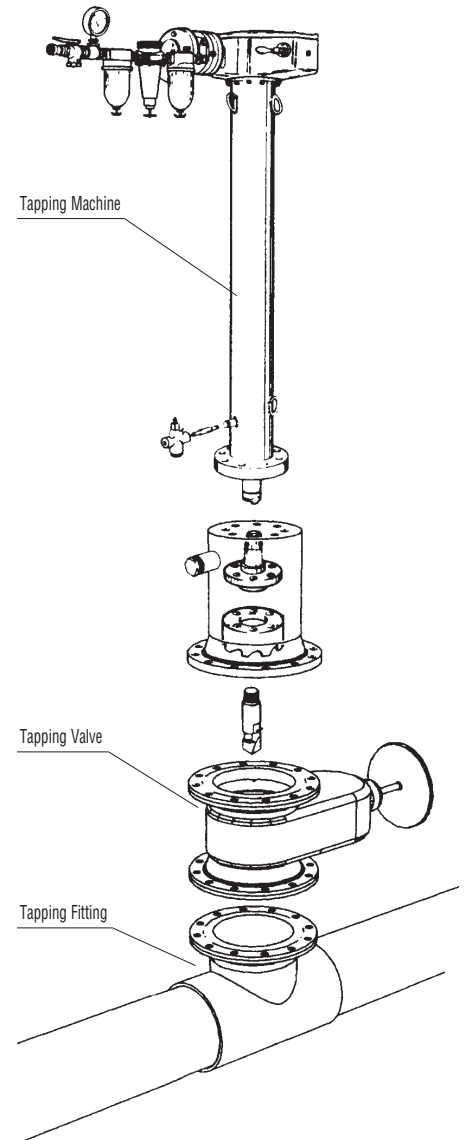

ISO 9001 Certified

Toll Free

1-888-TDWmSon (839-6766)



TDW Tapping Fittings

T 6 - S I Z E - F C O O - X Y

Example

T6-1408-1300-13 is a Tapping Fitting 14" (run) x 8" (branch), with an RFWN standard weight, standard material flange, class 300, and A 537 CL. 1 TDW Std. sleeve material per ASME B31.3 with back-up strips.

Run/Branch		Dim. H (in.)	Dim. H (in.)	Dim. H (in.)	Dim. D (in.)	Dim L (in.)	Dim T (in.)	Weight (lbs.)
Inches	(Nom.)	Class 150	Class 300	Class 600				Class 150
02	02	5.31	5.56	5.81	2.46	6.00	0.203	12
03	03	6.37	6.75	7.13	3.62	7.00	0.438	23
04	03	5.92	6.29	6.67	4.65	8.25	0.375	27
04	04	6.16	6.53	7.41	4.65	10.75	0.375	33
06	04	7.28	7.65	8.53	6.78	10.75	0.375	42
06	06	7.84	8.22	9.22	6.78	14.00	0.375	57
08	04	8.29	8.67	9.54	8.81	10.75	0.375	49
08	06	8.86	9.24	10.24	8.81	14.00	0.375	68
08	08	9.42	9.80	10.92	8.81	16.50	0.375	88
10	04	9.54	9.92	10.80	10.84	10.75	0.500	66
10	06	10.04	10.42	11.42	10.84	14.00	0.500	96
10	08	10.79	11.17	12.30	10.84	16.50	0.500	135
10	10	10.73	11.36	12.98	10.84	20.00	0.500	152
12	04	10.81	11.18	12.06	12.87	10.75	0.625	96
12	06	11.19	11.56	12.56	12.87	14.00	0.625	129
12	08	12.06	12.44	13.56	12.87	16.50	0.625	190
12	10	12.31	12.94	14.56	12.87	20.00	0.625	216
12	12	12.44	13.06	14.31	12.87	22.00	0.625	243
14	04	11.56	11.94	12.81	14.12	10.75	0.625	106
14	06	12.06	12.44	13.44	14.12	12.875	0.625	126
14	08	12.31	12.69	13.81	14.12	16.50	0.625	174
14	10	12.94	13.56	15.19	14.12	20.00	0.625	221
14	12	13.32	13.95	15.20	14.12	22.00	0.625	286
14	14	13.44	14.06	15.18	14.12	26.00	0.625	314
16	06	12.12	12.78	13.78	16.12	14.00	0.750	170
16	08	13.68	14.06	15.18	16.12	14.875	0.750	193
16	10	13.68	14.31	15.94	16.12	20.00	0.750	256
16	12	14.21	14.84	16.09	16.12	24.00	0.750	345
16	16	14.56	15.31	16.81	16.12	30.00	0.750	460
18	06	13.25	13.90	14.90	18.12	14.00	0.875	227
18	08	14.14	14.64	15.81	18.12	16.375	0.875	273
18	10	14.81	15.44	17.06	18.12	20.00	0.875	341
18	12	15.44	16.06	17.31	18.12	22.00	0.875	400
18	18	15.51	16.50	17.94	18.12	33.00	0.875	617
20	06	14.62	15.81	16.25	20.12	14.00	1.000	263
20	08	16.19	16.56	17.68	20.12	16.50	1.000	320
20	10	16.06	16.68	18.31	20.12	17.875	1.000	377
20	12	16.56	17.19	18.44	20.12	24.00	1.000	417
20	20	16.82	18.04	19.56	20.12	36.00	1.000	820
24	08	18.26	18.76	19.93	24.12	16.50	1.250	455
24	10	17.70	18.46	20.12	24.12	20.00	1.250	576
24	12	18.37	19.01	20.34	24.12	21.375	1.250	642
24	24	19.58	21.00	22.44	24.12	43.00	1.250	1373
30	30	22.63	24.00	26.75	30.12	56.00	1.375	2435



TDW Tapping Fittings

Weight (lbs.) Class 300	Weight (lbs.) Class 600	MAOP @ 100°F Class 600 B31.3 XY Options 03-33
14	17	1480
21	30	1480
25	34	1480
38	58	1480
47	66	1220
73	109	1200
54	73	1010
84	120	955
118	159	950
71	90	1110
112	148	1030
165	208	1020
190	276	995
101	120	1210
145	181	1110
220	263	1090
254	345	1040
297	383	955
111	130	1115
142	178	1045
204	247	980
259	350	975
340	424	890
393	537	935
186	222	1140
223	266	990
294	385	1025
399	505	1005
569	778	990
243	279	1190
303	346	1130
379	470	1060
453	537	945
770	1001	990
279	315	1260
350	393	1140
415	506	970
471	587	965
1011	1314	1000
485	528	1245
614	525	1160
696	780	980
1658	2077	1015
2893	3235	945

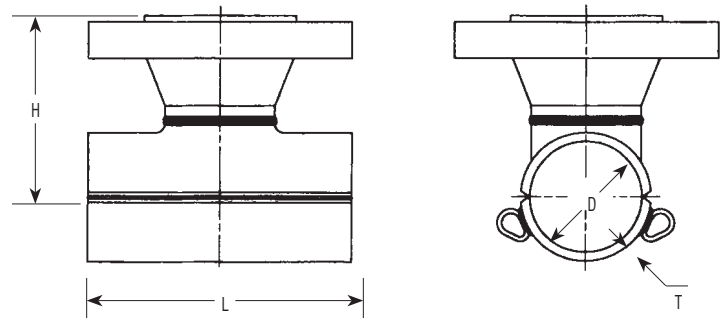

Option Y (Design Code)

Option	ASME Design Code
3	B31.3
4	B31.4 & B31.8 W/ 0.72 DF

Option X (Sleeve Material)

Option	Material
0	A 537 CL.1 TDW Std. material.
1	A 537 CL.1 TDW Std. material w/ back-up strips.
2	Low temp. material.
3	Low temp. material w/ back-up strips.
4	A 234 WPB S58 sleeve.
5	A 234 WPB S58 sleeve w/ back-up strips.

Option C (Class)

Option	Class
1	150
3	300
6	600

Option F (Flange Type)

Option	Flange Material
1	Flange, RFWN Std. Wt. Sch., A 105.
2	Flange, RFWN Std. Wt. Sch., A 350 LF2 for low temp. service.
3	Flange, RTJ Std. Wt. Sch., A 105.
4	Flange, RTJ Std. Wt. Sch., A 350 LF2 for low temp. service.

Maximum Allowable Operating Pressure @ 100°F (MAOP)

ASME Design Code	Class	Sleeve Material (X) Options 0 thru 3	Sleeve Material (X) Options 4 and 5
B31.3	150	285	285
Y=3	300	740	740
	600	See Chart	Consult Factory
B31.4*	150	285	285
Y=4	300	740	740
	600	1480	Consult Factory
B31.8	150	See chart	Consult Factory
B31.8	300	See chart	Consult Factory
B31.8	600	See chart	Consult Factory

*B31.4 applications allow MAOP to extend to 250°F



TDW Tapping Fittings

Maximum Allowable Operating Pressure (in PSI) based on A105 or A350 LF2 RFWN standard weight flanges (see Option "F" Options 1 thru 4) and A537 Class 1 sleeve material (see Option "X", Options 0 thru 3) per ASME B31.8 at -20 to +100° F.

Size	Design Factor for ASME Class 150				Part Number	Design Factor for ASME Class 300				Part Number	Design Factor for ASME Class 600				Part Number
	0.72	0.60	0.50	0.40		0.72	0.60	0.50	0.40		0.72	0.60	0.50	0.40	
2x2	285	285	285	285	T6-0202-F100-X4	740	740	740	740	T6-0202-F300-X4	1480	1480	1340	1070	T6-0202-F600-X4
3x3	285	285	285	285	T6-0303-F100-X4	740	740	740	740	T6-0303-F300-X4	1480	1355	1130	905	T6-0303-F600-X4
4x3	285	285	285	285	T6-0403-F100-X4	740	740	740	740	T6-0403-F300-X4	1480	1480	1480	1480	T6-0403-F600-X4
4x4	285	285	285	285	T6-0404-F100-X4	740	740	740	740	T6-0404-F300-X4	1480	1480	1480	1455	T6-0404-F600-X4
6x4	285	285	285	285	T6-0604-F100-X4	740	740	740	740	T6-0604-F300-X4	1480	1480	1320	1055	T6-0604-F600-X4
6x6	285	285	285	285	T6-0606-F100-X4	740	740	740	740	T6-0606-F300-X4	1480	1480	1295	1035	T6-0606-F600-X4
8x4	285	285	285	285	T6-0804-F100-X4	740	740	740	740	T6-0804-F300-X4	1480	1315	1095	875	T6-0804-F600-X4
8x6	285	285	285	285	T6-0806-F100-X4	740	740	740	740	T6-0806-F300-X4	1480	1240	1035	825	T6-0806-F600-X4
8x8	285	285	285	285	T6-0808-F100-X4	740	740	740	740	T6-0808-F300-X4	1480	1235	1030	825	T6-0808-F600-X4
10x4	285	285	285	285	T6-1004-F100-X4	740	740	740	740	T6-1004-F300-X4	1480	1430	1195	955	T6-1004-F600-X4
10x6	285	285	285	285	T6-1006-F100-X4	740	740	740	740	T6-1006-F300-X4	1480	1325	1105	885	T6-1006-F600-X4
10x8	285	285	285	285	T6-1008-F100-X4	740	740	740	740	T6-1008-F300-X4	1480	1320	1100	880	T6-1008-F600-X4
10x10	285	285	285	285	T6-1010-F100-X4	740	740	740	740	T6-1010-F300-X4	1480	1305	1085	870	T6-1010-F600-X4
12x4	285	285	285	285	T6-1204-F100-X4	740	740	740	740	T6-1204-F300-X4	1480	1480	1300	1040	T6-1204-F600-X4
12x6	285	285	285	285	T6-1206-F100-X4	740	740	740	740	T6-1206-F300-X4	1480	1420	1185	945	T6-1206-F600-X4
12x8	285	285	285	285	T6-1208-F100-X4	740	740	740	740	T6-1208-F300-X4	1480	1415	1175	940	T6-1208-F600-X4
12x10	285	285	285	285	T6-1210-F100-X4	740	740	740	740	T6-1210-F300-X4	1480	1380	1150	920	T6-1210-F600-X4
12x12	285	285	285	285	T6-1212-F100-X4	740	740	740	740	T6-1212-F300-X4	1480	1260	1050	840	T6-1212-F600-X4
14x4	285	285	285	285	T6-1404-F100-X4	740	740	740	740	T6-1404-F300-X4	1480	1440	1200	960	T6-1404-F600-X4
14x6	285	285	285	285	T6-1406-F100-X4	740	740	740	740	T6-1406-F300-X4	1480	1350	1125	900	T6-1406-F600-X4
14x8	285	285	285	285	T6-1408-F100-X4	740	740	740	740	T6-1408-F300-X4	1480	1260	1050	840	T6-1408-F600-X4
14x10	285	285	285	285	T6-1410-F100-X4	740	740	740	740	T6-1410-F300-X4	1480	1280	1065	850	T6-1410-F600-X4
14x12	285	285	285	285	T6-1412-F100-X4	740	740	740	740	T6-1412-F300-X4	1480	1275	1065	850	T6-1412-F600-X4
14x14	285	285	285	285	T6-1414-F100-X4	740	740	740	740	T6-1414-F300-X4	1480	1230	1025	820	T6-1414-F600-X4
16x6	285	285	285	285	T6-1606-F100-X4	740	740	740	740	T6-1606-F300-X4	1480	1465	1220	975	T6-1606-F600-X4
16x8	285	285	285	285	T6-1608-F100-X4	740	740	740	740	T6-1608-F300-X4	1480	1310	1090	870	T6-1608-F600-X4
16x10	285	285	285	285	T6-1610-F100-X4	740	740	740	740	T6-1610-F300-X4	1480	1340	1115	895	T6-1610-F600-X4
16x12	285	285	285	285	T6-1612-F100-X4	740	740	740	740	T6-1612-F300-X4	1480	1315	1095	875	T6-1612-F600-X4
16x16	285	285	285	285	T6-1616-F100-X4	740	740	740	675	T6-1616-F300-X4	1480	1285	1070	855	T6-1616-F600-X4
18x6	285	285	285	285	T6-1806-F100-X4	740	740	740	740	T6-1806-F300-X4	1480	1480	1270	1015	T6-1806-F600-X4
18x8	285	285	285	285	T6-1808-F100-X4	740	740	740	740	T6-1808-F300-X4	1480	1475	1230	980	T6-1808-F600-X4
18x10	285	285	285	285	T6-1810-F100-X4	740	740	740	740	T6-1810-F300-X4	1480	1400	1165	930	T6-1810-F600-X4
18x12	285	285	285	285	T6-1812-F100-X4	740	740	740	740	T6-1812-F300-X4	1480	1260	1050	840	T6-1812-F600-X4
18x18	285	285	285	285	T6-1818-F100-X4	740	740	740	740	T6-1818-F300-X4	1480	1300	1085	865	T6-1818-F600-X4
20x6	285	285	285	285	T6-2006-F100-X4	740	740	740	740	T6-2006-F300-X4	1480	1480	1350	1080	T6-2006-F600-X4
20x8	285	285	285	285	T6-2008-F100-X4	740	740	740	740	T6-2008-F300-X4	1480	1480	1240	990	T6-2008-F600-X4
20x10	285	285	285	285	T6-2010-F100-X4	740	740	740	740	T6-2010-F300-X4	1480	1315	1095	875	T6-2010-F600-X4
20x12	285	285	285	285	T6-2012-F100-X4	740	740	740	740	T6-2012-F300-X4	1480	1270	1060	845	T6-2012-F600-X4
20x20	285	285	285	285	T6-2020-F100-X4	740	740	740	732	T6-2020-F300-X4	1480	1325	1105	885	T6-2020-F600-X4
24x8	285	285	285	285	T6-2408-F100-X4	740	740	740	740	T6-2408-F300-X4	1480	1480	1395	1115	T6-2408-F600-X4
24x10	285	285	285	285	T6-2410-F100-X4	740	740	740	740	T6-2410-F300-X4	1480	1480	1222	978	T6-2410-F600-X4
24x12	285	285	285	285	T6-2412-F100-X4	740	740	740	740	T6-2412-F300-X4	1480	1350	1059	847	T6-2412-F600-X4
24x24	285	285	285	285	T6-2424-F100-X4	740	740	740	700	T6-2424-F300-X4	1480	1355	1125	900	T6-2424-F600-X4
30x30	285	285	285	285	T6-3030-F100-X4	740	740	740	740	T6-3030-F300-X4	1480	1255	1045	835	T6-3030-F600-X4