

# PIG-SIG® V

## Scraper Passage Indicator

Optional mounting system available



Bulletin No: 5110.003.12  
Version: 05.2021  
Supersedes: 5110.003.11 10.2020)



### Description

TDW's PIG-SIG® V Scraper Passage Indicator is a device installed at prescribed intervals on pipelines to detect the passage of a scraper or sphere. This unique product functions by extending an omnidirectional trigger into the pipeline through a welded fitting: the trigger is tripped by the passage of a scraper/sphere. The TDW PIG-SIG V Scraper Passage Indicator is easy to install, compatible with all standard and flanged THREAD-O-RING™ nipples.

Signaling systems available with the PIG-SIG V device include a flag indicator, an electrical indicator or a flag/electrical indicator. It is compatible with all standard THREAD-O-RING nipples previously sold by TDW and are interchangeable. This makes it possible to order the PIG-SIG V unit as an upgrade conversion kit without nipple, or as a new installation kit complete with nipple.

The PIG-SIG V device can also be provided in a flange-mounted configuration per the required pipeline pressure class (up to 1500 lb. standard).

### Features

Standard PIG-SIG V Passage Indicators are built to withstand the most severe offshore/onshore environments. Each PIG-SIG V device is weatherproof, corrosion-resistant, and all wetted components are NACE MR0175/ISO15156 compliant. All components exposed to pipeline products are completely sealed to prevent leakage. Components exposed to the atmosphere are all 316 stainless steel — except on electrical models, where the MICRO SWITCH™ is aluminum with a protective powder coating (unless stainless steel is specially requested).

The MICRO SWITCH flag indicator offers high visibility. Because the triggering toggle that extends into a pipe is omni-directional, it does not require adjustments after it is set. This means the flag can be oriented to face any desired direction. The carbon steel nipple is manufactured from easily weldable material. All PIG-SIG indicators can be installed on or removed from a pressurized pipeline by using a TDW T-101 Tapping Machine and accessories.

### Options

Available options:

- Flag Indicator with Manual Reset
- Electrical Indicator with Auto Reset
- Flag/Electrical Indicator combined
- Extended models, for installation on buried pipelines, are available in all configurations
- Varied materials and O-ring seals
- Unit can be thread-mounted to  
THREAD-O-RING nipple
- "Build your own" PIG-SIG V assembly  
from the charts on the pages  
of this product bulletin

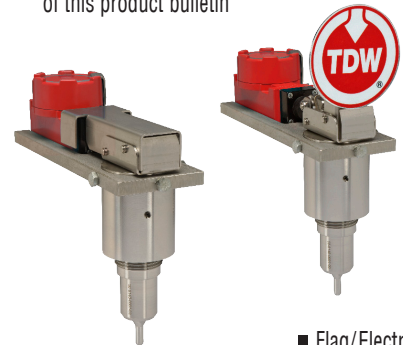

■ Electrical Indicator

■ Flag/Electrical Indicator

T.D. Williamson is committed to providing you with the right product to assist you in planning, budgeting and meeting the specifications for your individual application needs.

The PIG-SIG® V is patented in the U.S. (7861665) and other countries.

MICRO SWITCH™ is a trademark of Honeywell International, Inc.

# PIG-SIG® V Scraper Passage Indicator

04 - XXXX - XXXX -

### Class Options

Class*	Pipe Sizes	Mounting
9550	2 – 4-inch (50 – 100 mm)	TOR† Nipple-Mounted
9548	5-inch (125 mm) and Larger	TOR† Nipple-Mounted
4400	150 # RF	Flange-Mounted
4410	300 # RF	Flange-Mounted
4420	600 # RF	Flange-Mounted
4430	600 # RTJ	Flange-Mounted
4440	900 / 1500 # RF	Flange-Mounted
4450	900 / 1500 # RTJ	Flange-Mounted
4460	2500 # RF	Flange-Mounted

\* All Ratings are ANSI Class † TOR = THREAD-O-RING™

### Shaft Assembly

	Extension Length	
	0	1
0	None	None
1	12"	304.8 mm
2*	24"	609.6 mm
3*	36"	914.4 mm
4*	48"	1219.2 mm
5	60"	1524.0 mm
6	72"	1828.8 mm
7*	84"	2133.6 mm
8	96"	2438.4 mm
9*	108"	2743.2 mm
A*	120"	3048.0 mm

\* Special options available upon request. Factory lead times may vary.

### Plug Assembly

THREAD-O-RING™ Nipple-Mounted

0 = 316 Stainless Steel Omnidirectional

1\* = Naval Brass

\* Special options available upon request. Factory lead times may vary.

OPTIONAL



### Indicator Assembly

Indicator Option

0	Flag with Manual Reset
1	Electrical with Auto Reset
2	Flag/Electrical Combined
3*	Electrical with Auto Reset (Stainless Steel Switch Housing)
4*	Flag/Electrical Combined (Stainless Steel Switch Housing)

\* Special options available upon request. Factory lead times may vary.

Flag Indicator Assembly



Electrical Indicator Assembly

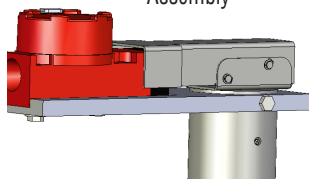

Flag/Electrical Indicator Assembly

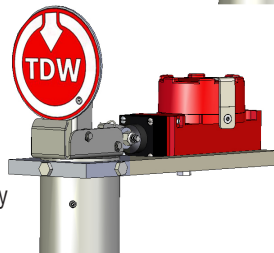

Extended Indicator



Flange-Mounted THREAD-O-RING™ Material Option

0	A105 & A350 LF2 CL1 Dual Certification	w/EN-10204 3.1
1	A105 & A350 LF2 CL1 Dual Certification	w/EN-10204 3.2
2	A182 F316 w/EN-10204 3.1 Certification	
3	A 182 F316 w/EN-10204 3.2 Certification	



### Example: 04-9548-0100-51

This example is a PIG-SIG V indicator with a THREAD-O-RING nipple and a nipple-mounted flag indicator, 12 in. extended shaft for 6 in. and larger pipe with .250 in. to .500 in. wall.

**Suffix \***

OPTION

**THREAD-O-RING™ Nipple-Mounted Options**

**Flange-Mounted Assembly Options**

O-Ring Material		Nom. Pipe Size		Wall Thickness		Nipple Length		Suffix
		in.	mm	in.	mm	in.	mm	
0	Explosive Decompression & Extrusion Resistant FKM	2	50	0.125 - 0.188	3.175 - 4.775	4.250	108.0	11
		2	50	0.189 - 0.375	4.801 - 9.525	4.125	104.8	07
1	Nitrile (Low Temp.)	2.5	65	0.125 - 0.188	3.175 - 4.775	4.250	108.0	10
2	Neoprene	2.5	65	0.189 - 0.375	4.801 - 9.525	4.125	104.8	06
3†	EPDM	3	80	0.062 - 0.125	1.575 - 3.175	4.375	111.1	24
4†	FFKM	3	80	0.125 - 0.188	3.175 - 4.775	4.250	108.0	09
5	Buna	3	80	0.189 - 0.375	4.801 - 9.525	4.125	104.8	05
6†	FKM	3	80	0.376 - 0.562	9.550 - 14.275	3.938	100.0	18
7†	PTFE	3.5	90	0.125 - 0.188	3.175 - 4.775	4.250	108.0	08
8†	Explosive Decompression Resistant TFE/P	3.5	90	0.189 - 0.375	4.801 - 9.525	4.125	104.8	04
		3.5	90	0.563 - 0.750	14.300 - 19.050	3.750	95.3	19
9†	FKM (Low Temp.)	4	100	0.125 - 0.188	3.175 - 4.775	4.250	108.0	03
		4	100	0.189 - 0.375	4.801 - 9.525	4.120	104.8	01
		4	100	0.376 - 0.500	9.550 - 12.700	3.938	100.0	17
		4	100	0.501 - 0.587	12.725 - 14.910	3.913	99.4	22
		4	100	0.588 - 0.750	14.935 - 19.050	3.750	95.3	21
		5	125	0.125 - 0.188	3.175 - 4.775	4.250	108.0	13
		5	125	0.189 - 0.375	4.801 - 9.525	4.125	104.8	12
		5	125	0.563 - 0.750	14.300 - 19.050	3.750	95.3	20
		6 & up	150 & up	0.250 - 0.499	6.350 - 12.675	4.000	101.6	51
		6 & up	150 & up	0.500 - 0.749	12.700 - 19.025	3.750	95.3	52
		6 & up	150 & up	0.750 - 0.999	19.050 - 25.375	3.500	88.9	53
		6 & up	150 & up	1.000 - 1.249	25.400 - 31.725	3.250	82.6	54
6 & up	150 & up	1.250 - 1.499	31.750 - 38.075	3.000	76.2	55		
6 & up	150 & up	1.500 - 1.750	38.100 - 44.450	2.750	69.9	56		
6 & up	150 & up	0.125 - 0.249	3.175 - 6.375	4.250	108.0	64		
Less Nipple								99

**Suffix**

Contact your TDW representative with pipe size, wall thickness, desired extension length and flange type to determine the appropriate 4-digit suffix.



† Special options available upon request. Factory lead times may vary.

THREAD-O-RING™ Nipple  
part number: 00-1023-0333-SUFFIX

5 in. & Smaller Pipe

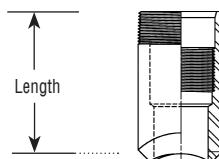

6 in. & Larger Pipe

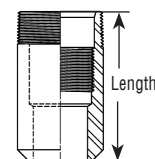



# PIG-SIG® V Scraper Passage Indicator

## THREAD-O-RING™ Nipple Material

Size & Grade:	2 NPS XXS ASTM A 333 Grade 6 seamless steel pipe
Tensile Requirements:	35,000 psi SMYS - 60,000 psi SMTS
Impact Requirements:	15 ft-lbf min. avg. three specimens
	12 ft-lbf min. one specimen only
	Impact Temperature -50° F
Chemical Requirements:	Composition, % - Carbon 0.22 max, Manganese 0.60-1.35
	Sulfur 0.01 max., Carbon Equivalent (IIW) 0.45 max
Test Report:	EN10204 3.1

## PIG-SIG V Pressure Temperature Ratings

Pressures are in pounds per square inch, gage (psig). Temperatures are in Fahrenheit.

Piping Code Temp. °F	B31.3	B31.4 F=.72	F=.72	F=.60	B31.8 F=.50	F=.40
-50	3200					
-20 to 200	3200	3750	3750	3120	2600	2080

## PIG-SIG V Pressure Temperature Ratings

Pressures are in bar. Temperatures are in Celsius.

Piping Code Temp. °C	B31.3	B31.4 F=.72	F=.72	F=.60	B31.8 F=.50	F=.40
-46	221					
-29 to 93	221	259	259	215	179	143

Rating shown for PIG-SIG V with 316 SS Plug Assembly and ASTM A333 Gr 6 THREAD-O-RING Nipple.

Rating do not include allowance for corrosion.

Due to magnet degradation, PIG-SIG V passage indication functionality is limited to 200F (93C).

O-Ring material selection must be suitable for service fluids and temperature requirements.

# PIG-SIG® V Scraper Passage Indicator

## Flag Indicator with Manual Reset

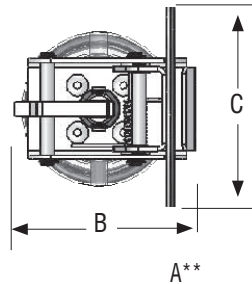
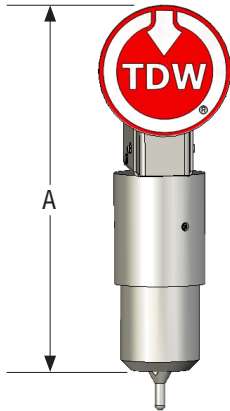

	A**		B		C		Weight		Part Number
	Inch	mm	Inch	mm	Inch	mm	Lb.	Kg.	
Standard:	11.26	286	3.09	78	4.00	101	9	4	04-9548-0000
Extended:									
	+36	900					20	9.0	04-9548-0300*
	+48	1200					25	11.5	04-9548-0400*
	+60	1500					29	13.0	04-9548-0500
	+72	1800					34	15.5	04-9548-0600
	+84	2000					39	18.0	04-9548-0700*
	+96	2500					44	20.5	04-9548-0800

The basic indicator includes:  
2 in. (50 mm) THREAD-O-RING™ nipple, plug assembly and indicator assembly.

The extended indicator includes the same items, as well as an extended length indicator assembly.

\* Special options available upon request. Factory lead times may vary.

\*\* Length "A" is estimated/varies per configuration. "A" values in millimeters are rounded.

NOTE: Extended lengths are added to Standard "A" length (example: 36-in Extended Length "A" is 47.26-in)

## Flag Indicator with Manual Reset - Electrical Indicator with Auto Reset Combined

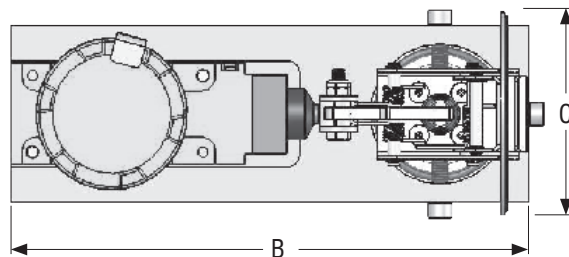
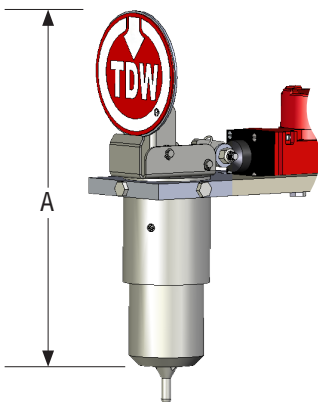

	A**		B		C		Weight		Part Number
	Inch	mm	Inch	mm	Inch	mm	Lb.	Kg.	
Standard:	11.26	286	10.25	260	4.125	105	14	6	04-9548-2000
Extended:									
	+36	900					25	11.0	04-9548-2300*
	+48	1200					30	14.0	04-9548-2400*
	+60	1500					35	16.0	04-9548-2500
	+72	1800					40	18.0	04-9548-2600
	+84	2000					45	20.0	04-9548-2700*
	+96	2500					50	23.0	04-9548-2800

The basic indicator includes: 2 in. (50 mm) THREAD-O-RING nipple, plug assembly and flag/electrical indicator assembly. The electrical indicator consists of a weatherproof, explosion-proof, ATEX Certified MICRO SWITCH™ (LSX, double-pole, double-throw).

The extended indicator includes the same items, as well as an extended length indicator assembly.

\* Special options available upon request. Factory lead times may vary.

\*\* Length "A" is estimated/varies per configuration. "A" values in millimeters are rounded.

NOTE: Extended lengths are added to Standard "A" length (example: 36-in Extended Length "A" is 47.26-in)

# PIG-SIG® V Scraper Passage Indicator

## Electrical Indicator with Auto Reset

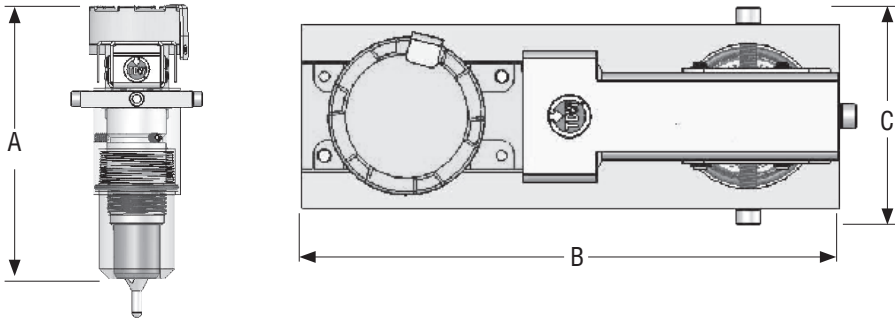

The basic indicator includes: 2 in. (50 mm) THREAD-O-RING™ nipple, plug assembly and electrical indicator assembly. The electrical indicator consists of a weatherproof, explosion-proof, ATEX Certified MICRO SWITCH™ (LSX, double-pole, double-throw).

The extended indicator includes the same items, as well as an extended length indicator assembly.

	A**		B		C		Weight		Part Number
	Inch	mm	Inch	mm	Inch	mm	Lb.	Kg.	
Standard:	8.76	223	10.25	260	4.125	105	14	6	04-9548-1000
Extended:									
	+36	900					25	11.0	04-9548-1300*
	+48	1200					30	14.0	04-9548-1400*
	+60	1500					35	16.0	04-9548-1500
	+72	1800					40	18.0	04-9548-1600
	+84	2000					45	20.0	04-9548-1700*
	+96	2500					50	23.0	04-9548-1800

\* Special options available upon request. Factory lead times may vary.

\*\* Length 'A': is estimated/varies per configuration. 'A' values in millimeters are rounded.

NOTE: Extended lengths are added to Standard 'A' length (example: 36-in Extended Length 'A' is 47.26-in)

**Optional Feature:** Transparent Cover/Enclosure Part Number: 04-3993-0000



# PIG-SIG® V Scraper Passage Indicator

## Electrical Indicator Switch Specifications

### MICRO SWITCH™ Electrical Diagram

Electrical specifications:

- Double-Pole
- 2 N.O., 2 N.C.
- 3/4 in. conduit

**Note:** When a Flag Indicator is used in combination with the electrical switch, the switch will open or close when the flag is reset.

### DPDT (2NC/2NO)

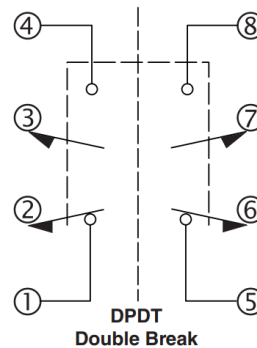

### Switch Specifications

MICRO SWITCH™	Weatherproof, explosion-proof switch BXC4L for use either indoors or outdoors in hazardous atmospheres
Temperature Range:	-40°F (-40°C) to 158°F (70°C)
Housing Materials:	Aluminum and Zinc (Optional: Stainless Steel)
Seals:	Fluorosilicone
NEMA Standards:	1, 3, 4, 4X, 6, 7, 9 and 13
UL listed (File No. E61730) and CSA certified (File No. LR57327):	Class I, Div. 1, Groups B, C, and D (Listings covered in Div. 1 are also covered in the same groups in Div. 2) Class II, Div. 1, Groups E, F and G (IEC standards: EExd IICT6, IP67)
Electrical Ratings:	10 amps continuous carry. Circuits on any one pole must be the same polarity
ATEX Certification:	EExd II T6 category II 2 GD, SIRA 00ATEX 1037X

### AC Volts - Pilot Duty: 600 VAC, 720VA

Circuitry	VAC	Amps at 0.35 Power Factor	
		Make	Break
Double-Pole, Double-Throw	120	30	3
	240	15	1.5
	480	7.5	0.75
	600	6	0.60

### DC Volts - Pilot Duty: 240 VDC, 30 watts

Circuitry	VDC	Make and Break Amps	
		Inductive	Resistive
Double-Pole, Double-Throw	24	10	10
	120	0.25	0.8
	240	0.15	0.4

# PIG-SIG® V Scraper Passage Indicator

## Recommended Spare Parts List

Component	Quantity in Assembly	Part Number
O-ring (Explosive Decompression Resistant FKM), Plug	1	00-8440-0003-00
Backup Ring	1	00-1586-0066-00
O-ring, Cap	1	00-8144-0001-00
Set Screw	3	00-8176-0001-00
1-inch Hex Plug Holder*	1	00-8138-0000-00
1-inch Hex Bit †	1	00-8235-0001-00
THREAD-O-RING Cleaner (w/ Brush & Magnet)*	1	04-3998-0000-00
THREAD-O-RING Thread Chaser	1	05-0347-0000-00
Magnet Holder Assm. with Filter Pack	1	04-4133-0000-00
Adapter (use w/ T-101)	1	00-8383-0000-00
Transparent Cover/Enclosure	1	04-3993-0000

\* If PIG-SIG V is to be installed or removed under pressure with removal tool, these component(s) will be required.

† If PIG-SIG V is to be installed with no pipeline pressure, these component(s) will be required.