



# Spherical 3-WAY™ Tee

with LOCK-O-RING® Flange - Sizes: 4- through 24-inch



T.D. Williamson, Inc.

Bulletin No: 2100.020.01

Date: February 2010

Cross Indexing No: n/a

Supersedes: 2100.020.00 (9/08)



## ■ Spherical 3-WAY™ Tee with LOCK-O-RING Flange

### Description

The 4-inch through 24-inch spherical three-way fittings are designed for use with STOPPLE® Plugging Equipment to temporarily stop flow in a line. A side or bottom outlet in the fittings permits installation of a bypass around the area where flow is stopped to keep the line in service. Spherical three-way fittings are furnished with LOCK-O-RING® Flanges drilled and faced to match ASME Class 150, 300 or 600 flanges. Other ASME Class ratings are available upon request. These fittings are available in 4- through 24-inch sizes.

### Features

Spherical three-way fittings are compact and low-profile, with a side outlet at the same level as the main. With 4-inch through 12-inch sizes, the bottom half of the fitting can also be repositioned 180 degrees from the flange to create a bottom outlet. For 16-inch and larger sizes, the fitting must

be specifically ordered as either a side or bottom outlet. Whether the outlet is to the side or on the bottom, the STOPPLE® Plugging Head can stop flow in the main line while flow continues through the outlet. These fittings may be used for lateral line tie-in, temporary relocation, or permanent relocation projects.

Spherical three-way fittings are designed to a maximum operating temperature of 180° F (82° C) as per ASME B31.4, or 100° F (38° C) as per ASME B31.8. All fittings are stamped with a serial number for complete material traceability. Material Test Reports are available upon request. Factory welding of these fittings is 100 percent radiographically inspected.

### Options

After work is completed, a LOCK-O-RING® Completion Plug can be installed in the neck of the fitting, permitting removal of the tapping valve. A blind flange can be installed, providing protection for the plug.

## ■ Typical Applications

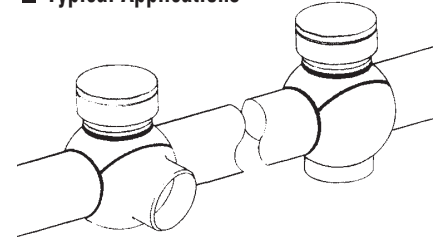

The bottom half of the Spherical 3-WAY™ Tee can be turned for either a side or bottom\* outlet as illustrated. The tee can also be installed horizontally.

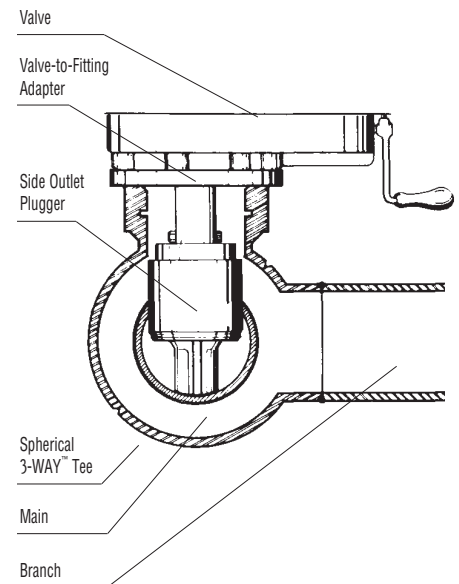

ISO 9001 Certified

Toll Free

**1-888-TDWmSon (839-6766)**



# Spherical 3-WAY™ Tee with LOCK-O-RING® Flange



■ 4- through 24-inch

## ASME Class 150

Maximum allowable operating pressure (in psi) per ASME B31.4 at -20 to 180° F = 285 psi.  
Maximum allowable operating pressure (in psi) per ASME B31.8 at -20 to 100°F see chart below.

Size		Weight		Design Factor				Part Number
Inches	DN	lbs	Kgs	.40	.50	.60	.72	
4	100	48	22	285	285	285	285	26-1863-0415-00
6	150	95	43	285	285	285	285	26-1863-0615-00
8	200	150	68	285	285	285	285	26-1863-0815-00
10	250	340	155	285	285	285	285	26-1863-1015-00
12	300	380	173	285	285	285	285	26-1863-1215-00
16	400	875	397	285	285	285	285	26-1101-0000-suff
18	450	1180	535	250	285	285	285	26-1061-0000-suff
20	500	1295	587	210	260	285	285	26-0906-0000-suff
24	600	2235	1013	185	230	275	285	26-0911-0000-suff

## ASME Class 300

Maximum allowable operating pressure (in psi) per ASME B31.4 at -20 to 180° F = 740 psi.  
Maximum allowable operating pressure (in psi) per ASME B31.8 at -20 to 100°F see chart below.

Size		Weight		Design Factor				Part Number
Inches	DN	lbs	Kgs	.40	.50	.60	.72	
4	100	60	27	435	545	650	740	26-1863-0430-00
6	150	100	45	410	510	615	740	26-1863-0630-00
8	200	160	73	495	620	740	740	26-1863-0830-00
10	250	340	155	500	625	740	740	26-1863-1030-00
12	300	380	173	470	590	710	740	26-1863-1230-00
16	400	890	202	445	555	670	740	26-1103-0000-suff
18	450	1200	544	410	515	615	740	26-1063-0000-suff
20	500	1310	594	410	510	615	740	26-0907-0000-suff
24	600	2350	1065	425	535	640	740	26-0912-0000-suff

## ASME Class 600

Maximum allowable operating pressure (in psi) per ASME B31.4 at -20 to 180° F = 1480 psi.  
Maximum allowable operating pressure (in psi) per ASME B31.8 at -20 to 100°F see chart below.

Size		Weight		Design Factor				Part Number
Inches	DN	lbs	Kgs	.40	.50	.60	.72	
4	100	75	34	1000	1250	1480	1480	26-1863-0460-00
6	150	160	73	890	1115	1340	1480	26-1863-0660-00
8	200	270	123	860	1075	1290	1480	26-1863-0860-00
10	250	540	245	830	1040	1245	1480	26-1863-1060-00
12	300	750	341	930	1165	1400	1480	26-1863-1260-00
16	400	1390	630	820	1025	1230	1480	26-1104-0000-suff
18	450	1865	846	820	1025	1230	1480	26-1064-0000-suff
20	500	2390	1084	825	1030	1235	1480	26-0908-0000-suff
24	600	3615	1639	820	1025	1230	1480	26-0914-0000-suff