



SHORTSTOPP® 3-WAY™ Tee

Sizes: 1-1/4- through 12-inch



T.D. Williamson

Bulletin No: 2100.002.03

Version: 09.2009

Cross Indexing No: n/a

Supersedes: 2100.002.02 (10.2002)



■ **Threaded 3-WAY Tee Fitting**
Sizes: 1-1/4" through 3"



■ **Flanged 3-WAY Tee Fitting**
Sizes: 4" through 12"

Description

TDW's 3-WAY™ Tee is designed for use with the TDW SHORTSTOPP® Plugging Machine Systems. It is used for main relocations, equipment tie-ins, lateral connections, line extensions and for making crossovers, all without shutdown.

The design of the 4" (DN 100) through 12" (DN 300) Type IIA 3-WAY Tee requires a reusable bolt-on flange adapter which adapts the tee to TDW SHORTCUTT® and SHORTSTOPP Valves.

When used with SHORTSTOPP Plugging

Features

Machines, the maximum recommended working pressure and temperature should be limited to that of the plugging equipment, but not exceeding that of the fitting itself.

All fittings are compatible with most ASME Class 150 applications. With the plugging equipment removed, the maximum working pressure is 285 psi (20 bar) at 100°F (38°C) or 245 psi (17 bar) at 180°F (82°C) per ASME B31.4. See chart on page 2 for MAOP per ASME B31.8.

Sizes 1-1/4" (DN 32) and 2" (DN 50) tees are forged ASTM A-105. Size 3" (DN 80) tees are ASTM A-234 Grade WPB steel. Sizes 4" through 12" (DN 100 - 300) tees are either fabricated from ASTM A-106 Grade B or ASTM A-234 Grade WPB steel.

ISO 9001 Certified

Toll Free

1-888-TDWmSon (839-6766)

■ Typical Setup

Sizes: 4" through 12" (100mm-300mm)

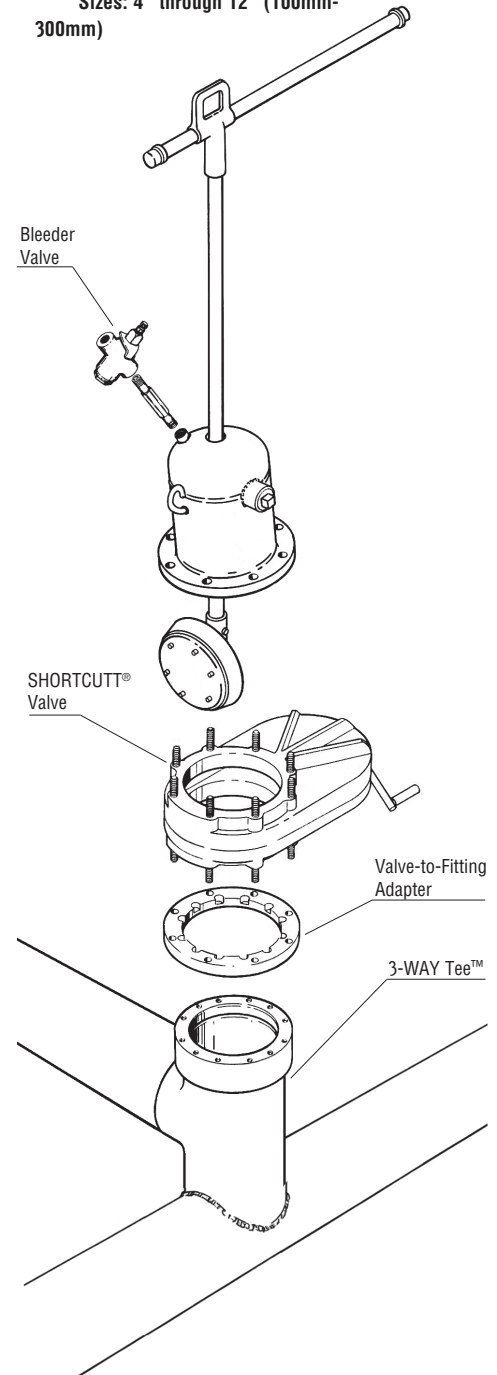



SHORTSTOPP® 3-WAY™ Tee

3-WAY™ Tee for SHORTSTOPP® 60 and SHORTSTOPP® 275

Maximum allowable operating pressure (in psi) per ASME B31.8 at -20 to +100° F

The 3-WAY Tee 1-1/4" through 3" includes: cap, completion plug, O-ring and tee.

The 3-WAY Tee 4" through 12" includes: cover flange with gasket, bolts and plastic caplugs, completion plug, O-Ring and tee.

Size	Weight		Design Factor				Part Number	
	Inches	DN	Lbs.	Kg.	0.72	0.60		0.50
1-1/4	32	4	2	285	285	285	285	06-6741-0000-00
1-1/2	38	4.5	2	285	285	285	285	26-0216-0000-00
2	50	5.5	2.5	285	285	285	285	26-0217-0000-00
3	80	11	5	285	285	285	285	26-0218-0000-00
4	100	36	16	285	285	285	285	06-7218-0000-00
6	150	51	23	285	285	285	285	06-7219-0000-00
8	200	92	42	285	285	285	285	06-7220-0000-00
10	250	162	74	285	285	285	225	06-7221-0000-00
12	300	240	109	285	265	220	175	06-7222-0000-00
3 x 4	80 x 100	11	5	285	285	285	285	26-0325-0304-01
4 x 6	100 x 150	35	16	285	285	285	285	06-7239-0406-01
6 x 8	150 x 200	50	23	285	285	285	285	06-7240-0608-01
8 x 10	200 x 250	125	57	285	285	285	285	06-7241-0810-01
8 x 12	200 x 300	125	57	285	285	285	285	06-7241-0812-01

Minimum Pipe Wall Thickness (Inches)

Size	Header Inches	Design Factor Min. Pipe Wall Thickness			
		0.72	0.60	0.50	0.40
1-1/4	1.660	0.019	0.023	0.027	0.034
1-1/2	1.900	0.021	0.026	0.031	0.039
2	2.375	0.027	0.032	0.039	0.048
3	3.500	0.040	0.048	0.057	0.071
4	4.500	0.051	0.061	0.073	0.092
6	6.625	0.075	0.090	0.108	0.135
8	8.625	0.098	0.177	0.140	0.176
10	10.750	0.122	0.146	0.175	0.219
12	12.750	0.144	0.173	0.208	0.260
3 x 4	4.500	0.051	0.061	0.073	0.092
4 x 6	6.625	0.075	0.090	0.108	0.135
6 x 8	8.625	0.098	0.117	0.140	0.176
8 x 10	10.750	0.122	0.146	0.175	0.219
8 x 12	12.750	0.144	0.173	0.208	0.260

Spare O-Rings & Gaskets

Size	DN	Spare O-Rings Part Number	Spare Gaskets Part Number
1-1/4	32	00-0117-0014	--
1-1/2	38	00-0117-0010	--
2	50	00-0117-0010	--
3	80	00-0017-0013	--
4	100	00-1250-0001	00-5238-0004
6	150	00-1250-0002	00-5238-0006
8	200	00-1250-0003	00-5238-0008
10	250	00-1250-0004	00-5238-0010
12	300	00-1250-0005	00-5238-0012
3 x 4	80 x 100	00-0017-0013	--
4 x 6	100 x 150	00-1250-0001	00-5235-0004
6 x 8	150 x 200	00-1250-0002	00-5238-0006
8 x 10	200 x 250	00-1250-0003	00-5238-0008
8 x 12	200 x 300	00-1250-0003	00-5238-0008

Note: The TDW fitting provides sufficient material thickness for itself and in many cases reinforcement for the branch opening in the pipe. However, the chart above specifies minimum wall thickness of the pipe for self reinforcement. (Based on 35,000 PSI SMYS)

SHORTSTOPP® 3-WAY™ Tee

Valve-to-Fitting Adapters for 4" through 12"

The 4" x 6", 6" x 8" and 10" x 12" adapters are used to adapt the valve to the next size smaller fittings.

Inches	DN	Lbs.	Kg.	Part Number
4	100	10	5	06-5724-0001
6	150	13	6	06-5724-0002
8	200	25	11	06-5724-0003
10	250	40	18	06-5724-0010
12	300	55	25	06-5724-0011
4 x 6	100 x 150	18	8	06-5724-0007
6 x 8	150 x 200	28.5	13	06-5724-0004
10 x 12	250 x 300	70	32	06-5724-0012

Dimensions

Size		A		B	
Inches	DN	Inches	mm	Inches	mm
1-1/4	32	4-3/4	121	2-5/8	67
1-1/2	38	6-5/16	160	2-9/16	65
2	50	5-1/4	133	3-1/4	83
3	80	7-3/16	183	4-3/4	121
4	100	9-13/16	249	6-3/4	171
6	150	13-1/4	338	8-13/16	224
8	200	14-13/16	376	10-3/4	273
10	250	19	483	14-7/8	378
12	300	21-1/2	546	17-3/8	441
3 x 4	80 x 100	7-3/16	183	4-3/4	121
4 x 6	100 x 150	9-13/16	249	6-3/4	171
6 x 8	150 x 200	13-5/16	338	8-13/16	224
8 x 10	200 x 250	14-13/16	376	10-3/4	273
8 x 12	200 x 300	19	483	14-7/8	378



■ Valve-to-Fitting Adapter

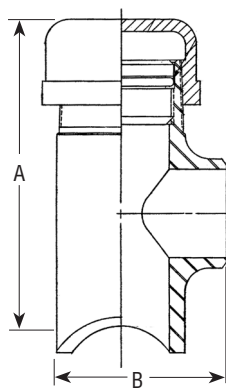

■ Sizes: 1-1/4" through 3"

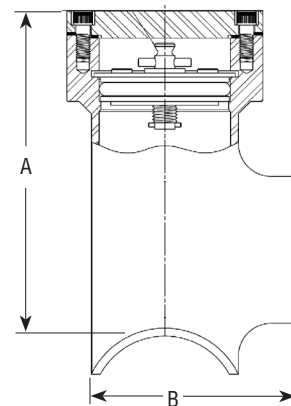

■ Sizes: 4" through 12"



T.D. Williamson

2100.002.03 Pg. 4