



D2000 Quick-Actuating Closures

Sizes: 32- to 48- inch



T.D. Williamson

Bulletin No: 5100.005.00

Version: 06.2020

Supersedes:



■ D2000 Quick-Actuating Closures

Description

The T.D. Williamson quick-actuating closure is easily operated by one person. The closure is designed primarily for horizontal installation, meaning the door swings open on the horizontal axis. However, the closure may be installed on a vertical installation. In the latter case, a counterbalance can be provided to facilitate opening.

Features

The closure, available in sizes 32-inch to 48-inch, offers important advantages:

A reliable seal – The large, cross-sectional diameter O-ring located on the periphery of the closure's barrel collar provides positive sealing as well as protection from damage by tools, pigs or debris.

Pressure indicating device – The closure is equipped with a pressure warning lock, in accordance with UG-35 of ASME BPVC Sect. VIII, Div. 1, to alert the operator to the existence of internal pressure prior to opening the closure.

Safe, reliable operation – After being safely depressurized, the D2000 closure can be opened or close in a single motion while the operator stands safely to the side by utilizing the side screw assist feature. The closure also has a door assist to aid in closing the door

Options

T.D. Williamson is committed to providing you with the exact product to assist you in planning, budgeting and meeting the specifications for your individual application needs.

Expanded Mechanical Options:

- Flanged Closure

Expanded Range of Applications:

- ASME B31.4/31.8 and CSA Z662 Category II, 0.5 and 0.6 design factors, ANSI class 600
- Standard ASME BPVC Sec. VIII Div 1 U-Stamp on door
- NACE MR0175 compliant
- -50 to +250 F (-45.5 to 121 C)

Consult factory for optional items.

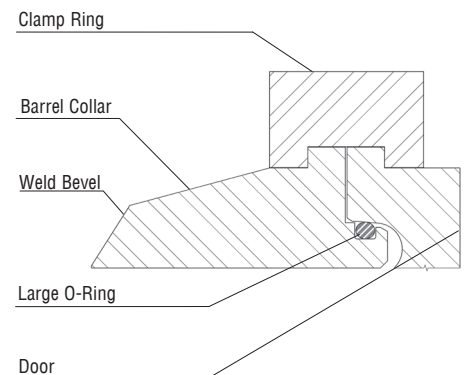

Dimensions and Part Numbers



T.D. Williamson

5100.003 - p2

32-inch ASME B31.4/B31.8/CSA Z662 Cat. II

Size (in)	Part Numbers	Hinge Orientation	Wall Thickness	Nitrile	Low-Temp Nitrile	FKM	Low-Temp FKM
32	12361730	RH	1.000in	19-3700-3068-50	19-3700-3068-51	19-3700-3068-53	19-3700-3068-55
32	12361731	RH	.875in	19-3700-3068-50	19-3700-3068-51	19-3700-3068-53	19-3700-3068-55
32	12361732	RH	.750in	19-3700-3068-50	19-3700-3068-51	19-3700-3068-53	19-3700-3068-55
32	12361733	RH	.625in	19-3700-3068-50	19-3700-3068-51	19-3700-3068-53	19-3700-3068-55
32	12361734	RH	.500in	19-3700-3068-50	19-3700-3068-51	19-3700-3068-53	19-3700-3068-55
32	12361735	RH	.375in	19-3700-3068-50	19-3700-3068-51	19-3700-3068-53	19-3700-3068-55
32	12362969	RH	.250in	19-3700-3068-50	19-3700-3068-51	19-3700-3068-53	19-3700-3068-55
32	12361742	LH	1.000in	19-3700-3068-50	19-3700-3068-51	19-3700-3068-53	19-3700-3068-55
32	12361743	LH	.875in	19-3700-3068-50	19-3700-3068-51	19-3700-3068-53	19-3700-3068-55
32	12361744	LH	.750in	19-3700-3068-50	19-3700-3068-51	19-3700-3068-53	19-3700-3068-55
32	12361745	LH	.625in	19-3700-3068-50	19-3700-3068-51	19-3700-3068-53	19-3700-3068-55
32	12361746	LH	.500in	19-3700-3068-50	19-3700-3068-51	19-3700-3068-53	19-3700-3068-55
32	12361747	LH	.375in	19-3700-3068-50	19-3700-3068-51	19-3700-3068-53	19-3700-3068-55
32	12362971	LH	.250in	19-3700-3068-50	19-3700-3068-51	19-3700-3068-53	19-3700-3068-55
32	12363246*	RH		19-3700-3068-50	19-3700-3068-51	19-3700-3068-53	19-3700-3068-55
32	12363248*	LH		19-3700-3068-50	19-3700-3068-51	19-3700-3068-53	19-3700-3068-55

NOTICE: See additional O-ring part number tables for common O-ring options (must be ordered separately). Other O-ring materials are also available on a special-order basis.

Dimensions and Weights

Size	Wt (Lbs)	H x W x L
32	2743	17 x 54 x 70

* Flanged
Maximum test pressure is 1.5 times design pressure.

Dimensions and Part Numbers



T.D. Williamson

5100.005 - p3

34-inch ASME B31.4/31.8/CSA Z662 Cat. II

Size (in)	Part Number	Hinge Orientation	Wall Thickness	Nitrile	Low-Temp Nitrile	FKM	Low-Temp FKM
34	12361754	RH	1.000in	19-3700-3250-50	19-3700-3250-51	19-3700-3250-53	19-3700-3250-55
34	12361755	RH	.875in	19-3700-3250-50	19-3700-3250-51	19-3700-3250-53	19-3700-3250-55
34	12361756	RH	.750in	19-3700-3250-50	19-3700-3250-51	19-3700-3250-53	19-3700-3250-55
34	12361757	RH	.625in	19-3700-3250-50	19-3700-3250-51	19-3700-3250-53	19-3700-3250-55
34	12361758	RH	.500in	19-3700-3250-50	19-3700-3250-51	19-3700-3250-53	19-3700-3250-55
34	12361759	RH	.375in	19-3700-3250-50	19-3700-3250-51	19-3700-3250-53	19-3700-3250-55
34	12362965	RH	.250in	19-3700-3250-50	19-3700-3250-51	19-3700-3250-53	19-3700-3250-55
34	12362966	RH	.250in	19-3700-3250-50	19-3700-3250-51	19-3700-3250-53	19-3700-3250-55
34	12361766	LH	1.000in	19-3700-3250-50	19-3700-3250-51	19-3700-3250-53	19-3700-3250-55
34	12361767	LH	.875in	19-3700-3250-50	19-3700-3250-51	19-3700-3250-53	19-3700-3250-55
34	12361768	LH	.750in	19-3700-3250-50	19-3700-3250-51	19-3700-3250-53	19-3700-3250-55
34	12361769	LH	.625in	19-3700-3250-50	19-3700-3250-51	19-3700-3250-53	19-3700-3250-55
34	12361770	LH	.500in	19-3700-3250-50	19-3700-3250-51	19-3700-3250-53	19-3700-3250-55
34	12361771	LH	.375in	19-3700-3250-50	19-3700-3250-51	19-3700-3250-53	19-3700-3250-55
34	12362967	LH	.250in	19-3700-3250-50	19-3700-3250-51	19-3700-3250-53	19-3700-3250-55
34	12363250*	RH		19-3700-3250-50	19-3700-3250-51	19-3700-3250-53	19-3700-3250-55
34	12363252*	LH		19-3700-3250-50	19-3700-3250-51	19-3700-3250-53	19-3700-3250-55

Dimensions and Weights

Size	Wt (Lbs)	H x W x L
34	3087	18 x 56 x 73

* Flanged
Maximum test pressure is
1.5 times design pressure.

Dimensions and Part Numbers



T.D. Williamson

5100.005 - p4

36-inch ASME B31.4/31.8/CSA Z662 Cat. II

Size (in)	Part Number	Hinge Orientation	Wall Thickness	Nitrile	Low-Temp Nitrile	FKM	Low-Temp FKM
36	12351953	RH	1.125in	19-3700-3432-50	19-3700-3432-51	19-3700-3432-53	19-3700-3432-55
36	12356004	RH	1.000in	19-3700-3432-50	19-3700-3432-51	19-3700-3432-53	19-3700-3432-55
36	12355824	RH	.875in	19-3700-3432-50	19-3700-3432-51	19-3700-3432-53	19-3700-3432-55
36	12355825	RH	.750in	19-3700-3432-50	19-3700-3432-51	19-3700-3432-53	19-3700-3432-55
36	12355826	RH	.625in	19-3700-3432-50	19-3700-3432-51	19-3700-3432-53	19-3700-3432-55
36	12355827	RH	.500in	19-3700-3432-50	19-3700-3432-51	19-3700-3432-53	19-3700-3432-55
36	12355828	RH	.375in	19-3700-3432-50	19-3700-3432-51	19-3700-3432-53	19-3700-3432-55
36	12356007	LH	1.000in	19-3700-3432-50	19-3700-3432-51	19-3700-3432-53	19-3700-3432-55
36	12355835	LH	.875in	19-3700-3432-50	19-3700-3432-51	19-3700-3432-53	19-3700-3432-55
36	12355836	LH	.750in	19-3700-3432-50	19-3700-3432-51	19-3700-3432-53	19-3700-3432-55
36	12355837	LH	.625in	19-3700-3432-50	19-3700-3432-51	19-3700-3432-53	19-3700-3432-55
36	12355838	LH	.500in	19-3700-3432-50	19-3700-3432-51	19-3700-3432-53	19-3700-3432-55
36	12355839	LH	.375in	19-3700-3432-50	19-3700-3432-51	19-3700-3432-53	19-3700-3432-55
36	12363231*	RH		19-3700-3432-50	19-3700-3432-51	19-3700-3432-53	19-3700-3432-55
36	12363232*	LH		19-3700-3432-50	19-3700-3432-51	19-3700-3432-53	19-3700-3432-55

Dimensions and Weights

Size	Wt (Lbs)	H x W x L
36	3523	18 x 58 x 76

* Flanged
Maximum test pressure is
1.5 times design pressure.

Dimensions and Part Numbers



T.D. Williamson

5100.005 - p5

38-inch

ASME B31.4/31.8/CSA Z662 Cat. II

Size (in)	Part Number	Hinge Orientation	Wall Thickness	Nitrile	Low-Temp Nitrile	FKM	Low-Temp FKM
38	12363225	RH	1.250in	19-3700-3682-50	19-3700-3682-51	19-3700-3682-53	19-3700-3682-55
38	12361778	RH	1.125in	19-3700-3682-50	19-3700-3682-51	19-3700-3682-53	19-3700-3682-55
38	12361779	RH	1.000in	19-3700-3682-50	19-3700-3682-51	19-3700-3682-53	19-3700-3682-55
38	12361780	RH	.875in	19-3700-3682-50	19-3700-3682-51	19-3700-3682-53	19-3700-3682-55
38	12361781	RH	.750in	19-3700-3682-50	19-3700-3682-51	19-3700-3682-53	19-3700-3682-55
38	12361782	RH	.625in	19-3700-3682-50	19-3700-3682-51	19-3700-3682-53	19-3700-3682-55
38	12361783	RH	.500in	19-3700-3682-50	19-3700-3682-51	19-3700-3682-53	19-3700-3682-55
38	12361784	RH	.375in	19-3700-3682-50	19-3700-3682-51	19-3700-3682-53	19-3700-3682-55
38	12363223	LH	1.250in	19-3700-3682-50	19-3700-3682-51	19-3700-3682-53	19-3700-3682-55
38	12361792	LH	1.125in	19-3700-3682-50	19-3700-3682-51	19-3700-3682-53	19-3700-3682-55
38	12361793	LH	1.000in	19-3700-3682-50	19-3700-3682-51	19-3700-3682-53	19-3700-3682-55
38	12361794	LH	.875in	19-3700-3682-50	19-3700-3682-51	19-3700-3682-53	19-3700-3682-55
38	12361795	LH	.750in	19-3700-3682-50	19-3700-3682-51	19-3700-3682-53	19-3700-3682-55
38	12361796	LH	.625in	19-3700-3682-50	19-3700-3682-51	19-3700-3682-53	19-3700-3682-55
38	12361797	LH	.500in	19-3700-3682-50	19-3700-3682-51	19-3700-3682-53	19-3700-3682-55
38	12361798	LH	.375in	19-3700-3682-50	19-3700-3682-51	19-3700-3682-53	19-3700-3682-55
38	12363254*	RH		19-3700-3682-50	19-3700-3682-51	19-3700-3682-53	19-3700-3682-55
38	12363256*	LH		19-3700-3682-50	19-3700-3682-51	19-3700-3682-53	19-3700-3682-55

Dimensions and Weights

Size	Wt (Lbs)	H x W x L
38	4341	20 x 61 x 79

* Flanged
Maximum test pressure is
1.5 times design pressure.

Dimensions and Part Numbers



T.D. Williamson

5100.005 - p6

40-inch

ASME B31.4/31.8/CSA Z662 Cat. II

Size (in)	Part Number	Hinge Orientation	Wall Thickness	Nitrile	Low-Temp Nitrile	FKM	Low-Temp FKM
40	12361806	RH	1.250in	19-3700-3864-50	19-3700-3864-51	19-3700-3864-53	19-3700-3864-55
40	12361807	RH	1.125in	19-3700-3864-50	19-3700-3864-51	19-3700-3864-53	19-3700-3864-55
40	12361808	RH	1.000in	19-3700-3864-50	19-3700-3864-51	19-3700-3864-53	19-3700-3864-55
40	12361809	RH	.875in	19-3700-3864-50	19-3700-3864-51	19-3700-3864-53	19-3700-3864-55
40	12361810	RH	.750in	19-3700-3864-50	19-3700-3864-51	19-3700-3864-53	19-3700-3864-55
40	12361811	RH	.625in	19-3700-3864-50	19-3700-3864-51	19-3700-3864-53	19-3700-3864-55
40	12361812	RH	.500in	19-3700-3864-50	19-3700-3864-51	19-3700-3864-53	19-3700-3864-55
40	12363212	RH	.375in	19-3700-3864-50	19-3700-3864-51	19-3700-3864-53	19-3700-3864-55
40	12361820	LH	1.250in	19-3700-3864-50	19-3700-3864-51	19-3700-3864-53	19-3700-3864-55
40	12361821	LH	1.125in	19-3700-3864-50	19-3700-3864-51	19-3700-3864-53	19-3700-3864-55
40	12361822	LH	1.000in	19-3700-3864-50	19-3700-3864-51	19-3700-3864-53	19-3700-3864-55
40	12361823	LH	.875in	19-3700-3864-50	19-3700-3864-51	19-3700-3864-53	19-3700-3864-55
40	12361824	LH	.750in	19-3700-3864-50	19-3700-3864-51	19-3700-3864-53	19-3700-3864-55
40	12361825	LH	.625in	19-3700-3864-50	19-3700-3864-51	19-3700-3864-53	19-3700-3864-55
40	12361826	LH	.500in	19-3700-3864-50	19-3700-3864-51	19-3700-3864-53	19-3700-3864-55
40	12363214	LH	.375in	19-3700-3864-50	19-3700-3864-51	19-3700-3864-53	19-3700-3864-55
40	12363258*	RH		19-3700-3864-50	19-3700-3864-51	19-3700-3864-53	19-3700-3864-55
40	12363260*	LH		19-3700-3864-50	19-3700-3864-51	19-3700-3864-53	19-3700-3864-55

Dimensions and Weights

Size	Wt (Lbs)	H x W x L
40	4895	21 x 63 x 81

* Flanged
Maximum test pressure is 1.5 times design pressure.

Dimensions and Part Numbers

42-inch

ASME B31.4/31.8/CSA Z662 Cat. II



T.D. Williamson

5100.005 - p7

Size (in)	Part Number	Hinge Orientation	Wall Thickness	Nitrile	Low-Temp Nitrile	FKM	Low-Temp FKM
42	12353616	RH	1.250in	19-3700-4023-50	19-3700-4023-51	19-3700-4023-53	19-3700-4023-55
42	12353617	RH	1.125in	19-3700-4023-50	19-3700-4023-51	19-3700-4023-53	19-3700-4023-55
42	12353618	RH	1.000in	19-3700-4023-50	19-3700-4023-51	19-3700-4023-53	19-3700-4023-55
42	12353619	RH	.875in	19-3700-4023-50	19-3700-4023-51	19-3700-4023-53	19-3700-4023-55
42	12353620	RH	.750in	19-3700-4023-50	19-3700-4023-51	19-3700-4023-53	19-3700-4023-55
42	12353621	RH	.625in	19-3700-4023-50	19-3700-4023-51	19-3700-4023-53	19-3700-4023-55
42	12353622	RH	.500in	19-3700-4023-50	19-3700-4023-51	19-3700-4023-53	19-3700-4023-55
42	12362813	RH	.375in	19-3700-4023-50	19-3700-4023-51	19-3700-4023-53	19-3700-4023-55
42	12356279	LH	1.250in	19-3700-4023-50	19-3700-4023-51	19-3700-4023-53	19-3700-4023-55
42	12356280	LH	1.125in	19-3700-4023-50	19-3700-4023-51	19-3700-4023-53	19-3700-4023-55
42	12356281	LH	1.000in	19-3700-4023-50	19-3700-4023-51	19-3700-4023-53	19-3700-4023-55
42	12356282	LH	.875in	19-3700-4023-50	19-3700-4023-51	19-3700-4023-53	19-3700-4023-55
42	12356283	LH	.750in	19-3700-4023-50	19-3700-4023-51	19-3700-4023-53	19-3700-4023-55
42	12356284	LH	.625in	19-3700-4023-50	19-3700-4023-51	19-3700-4023-53	19-3700-4023-55
42	12356285	LH	.500in	19-3700-4023-50	19-3700-4023-51	19-3700-4023-53	19-3700-4023-55
42	12362854	LH	.375in	19-3700-4023-50	19-3700-4023-51	19-3700-4023-53	19-3700-4023-55
42	12363233*	RH		19-3700-4023-50	19-3700-4023-51	19-3700-4023-53	19-3700-4023-55
42	12363234*	LH		19-3700-4023-50	19-3700-4023-51	19-3700-4023-53	19-3700-4023-55

Dimensions and Weights

Size	Wt (Lbs)	H x W x L
42	5040	20 x 66 x 83

* Flanged

Maximum test pressure is 1.5 times design pressure.

Dimensions and Part Numbers



T.D. Williamson

5100.005 - p8

44-inch

ASME B31.4/31.8/CSA Z662 Cat. II

Size (in)	Part Number	Hinge Orientation	Wall Thickness	Nitrile	Low-Temp Nitrile	FKM	Low-Temp FKM
44	12359080	RH	1.125in	19-3700-4227-50	19-3700-4227-51	19-3700-4227-53	19-3700-4227-55
44	12359081	RH	1.000in	19-3700-4227-50	19-3700-4227-51	19-3700-4227-53	19-3700-4227-55
44	12359082	RH	.875in	19-3700-4227-50	19-3700-4227-51	19-3700-4227-53	19-3700-4227-55
44	12359083	RH	.750in	19-3700-4227-50	19-3700-4227-51	19-3700-4227-53	19-3700-4227-55
44	12359084	RH	.625in	19-3700-4227-50	19-3700-4227-51	19-3700-4227-53	19-3700-4227-55
44	12359085	RH	.500in	19-3700-4227-50	19-3700-4227-51	19-3700-4227-53	19-3700-4227-55
44	12359086	RH	.375in	19-3700-4227-50	19-3700-4227-51	19-3700-4227-53	19-3700-4227-55
44	12366081	RH	.250in	19-3700-4227-50	19-3700-4227-51	19-3700-4227-53	19-3700-4227-55
44	12361834	LH	1.125in	19-3700-4227-50	19-3700-4227-51	19-3700-4227-53	19-3700-4227-55
44	12361835	LH	1.000in	19-3700-4227-50	19-3700-4227-51	19-3700-4227-53	19-3700-4227-55
44	12361836	LH	.875in	19-3700-4227-50	19-3700-4227-51	19-3700-4227-53	19-3700-4227-55
44	12361837	LH	.750in	19-3700-4227-50	19-3700-4227-51	19-3700-4227-53	19-3700-4227-55
44	12361838	LH	.625in	19-3700-4227-50	19-3700-4227-51	19-3700-4227-53	19-3700-4227-55
44	12361839	LH	.500in	19-3700-4227-50	19-3700-4227-51	19-3700-4227-53	19-3700-4227-55
44	12361840	LH	.375in	19-3700-4227-50	19-3700-4227-51	19-3700-4227-53	19-3700-4227-55
44	12366083	LH	.250in	19-3700-4227-50	19-3700-4227-51	19-3700-4227-53	19-3700-4227-55
44	12363262*	RH		19-3700-4409-50	19-3700-4409-51	19-3700-4409-53	19-3700-4409-55
44	12363264*	LH		19-3700-4409-50	19-3700-4409-51	19-3700-4409-53	19-3700-4409-55

Dimensions and Weights

Size	Wt (Lbs)	H x W x L
44	5975	21 x 68 x 85

* Flanged
Maximum test pressure is
1.5 times design pressure.

Dimensions and Part Numbers

46-inch ASME B31.4/31.8/CSA Z662 Cat. II



T.D. Williamson
5100.005 - p9

Dimensions and Weights

Size (in)	Part Number	Hinge Orientation	Wall Thickness	Nitrile	Low-Temp Nitrile	FKM	Low-Temp FKM
46	12361848	RH	1.250in	19-3700-4409-50	19-3700-4409-51	19-3700-4409-53	19-3700-4409-55
46	12361849	RH	1.125in	19-3700-4409-50	19-3700-4409-51	19-3700-4409-53	19-3700-4409-55
46	12361850	RH	1.000in	19-3700-4409-50	19-3700-4409-51	19-3700-4409-53	19-3700-4409-55
46	12361851	RH	.875in	19-3700-4409-50	19-3700-4409-51	19-3700-4409-53	19-3700-4409-55
46	12361852	RH	.750in	19-3700-4409-50	19-3700-4409-51	19-3700-4409-53	19-3700-4409-55
46	12361853	RH	.625in	19-3700-4409-50	19-3700-4409-51	19-3700-4409-53	19-3700-4409-55
46	12361854	RH	.500in	19-3700-4409-50	19-3700-4409-51	19-3700-4409-53	19-3700-4409-55
46	12362961	RH	.375in	19-3700-4409-50	19-3700-4409-51	19-3700-4409-53	19-3700-4409-55
46	12361862	LH	1.250in	19-3700-4409-50	19-3700-4409-51	19-3700-4409-53	19-3700-4409-55
46	12361863	LH	1.125in	19-3700-4409-50	19-3700-4409-51	19-3700-4409-53	19-3700-4409-55
46	12361864	LH	1.000in	19-3700-4409-50	19-3700-4409-51	19-3700-4409-53	19-3700-4409-55
46	12361865	LH	.875in	19-3700-4409-50	19-3700-4409-51	19-3700-4409-53	19-3700-4409-55
46	12361866	LH	.750in	19-3700-4409-50	19-3700-4409-51	19-3700-4409-53	19-3700-4409-55
46	12361867	LH	.625in	19-3700-4409-50	19-3700-4409-51	19-3700-4409-53	19-3700-4409-55
46	12361868	LH	.500in	19-3700-4409-50	19-3700-4409-51	19-3700-4409-53	19-3700-4409-55
46	12362963	LH	.375in	19-3700-4409-50	19-3700-4409-51	19-3700-4409-53	19-3700-4409-55
46	12363266*	RH		19-3700-4591-50	19-3700-4591-51	19-3700-4591-53	19-3700-4591-55
46	12363268*	LH		19-3700-4591-50	19-3700-4591-51	19-3700-4591-53	19-3700-4591-55

Size	Wt (Lbs)	H x W x L
46	6742	22 x 70 x 87

* Flanged
Maximum test pressure is
1.5 times design pressure.

Dimensions and Part Numbers

48-inch

ASME B31.4/31.8/GSA Z662 Cat. II



T.D. Williamson

5100.005 - p10

Size (in)	Part Number	Hinge Orientation	Wall Thickness	Nitrile	Low-Temp Nitrile	FKM	Low-Temp FKM
48	12361876	RH	1.250in	19-3700-4591-50	19-3700-4591-51	19-3700-4591-53	19-3700-4591-55
48	12361877	RH	1.125in	19-3700-4591-50	19-3700-4591-51	19-3700-4591-53	19-3700-4591-55
48	12361878	RH	1.000in	19-3700-4591-50	19-3700-4591-51	19-3700-4591-53	19-3700-4591-55
48	12361879	RH	.875in	19-3700-4591-50	19-3700-4591-51	19-3700-4591-53	19-3700-4591-55
48	12361880	RH	.750in	19-3700-4591-50	19-3700-4591-51	19-3700-4591-53	19-3700-4591-55
48	12361881	RH	.625in	19-3700-4591-50	19-3700-4591-51	19-3700-4591-53	19-3700-4591-55
48	12361882	RH	.500in	19-3700-4591-50	19-3700-4591-51	19-3700-4591-53	19-3700-4591-55
48	12363116	RH	.375in	19-3700-4591-50	19-3700-4591-51	19-3700-4591-53	19-3700-4591-55
48	12361890	LH	1.250in	19-3700-4591-50	19-3700-4591-51	19-3700-4591-53	19-3700-4591-55
48	12361891	LH	1.125in	19-3700-4591-50	19-3700-4591-51	19-3700-4591-53	19-3700-4591-55
48	12361892	LH	1.000in	19-3700-4591-50	19-3700-4591-51	19-3700-4591-53	19-3700-4591-55
48	12361893	LH	.875in	19-3700-4591-50	19-3700-4591-51	19-3700-4591-53	19-3700-4591-55
48	12361894	LH	.750in	19-3700-4591-50	19-3700-4591-51	19-3700-4591-53	19-3700-4591-55
48	12361895	LH	.625in	19-3700-4591-50	19-3700-4591-51	19-3700-4591-53	19-3700-4591-55
48	12361896	LH	.500in	19-3700-4591-50	19-3700-4591-51	19-3700-4591-53	19-3700-4591-55
48	12363113	LH	.375in	19-3700-4591-50	19-3700-4591-51	19-3700-4591-53	19-3700-4591-55
48	12363270*	RH		19-3700-4591-50	19-3700-4591-51	19-3700-4591-53	19-3700-4591-55
48	12363272*	LH		19-3700-4591-50	19-3700-4591-51	19-3700-4591-53	19-3700-4591-55

Dimensions and Weights

Size	Wt (Lbs)	H x W x L
48	7137	22 x 73 x 90

* Flanged
Maximum test pressure is 1.5 times design pressure.

Dimensions and Part Numbers



T.D. Williamson

5100.003 - p11

32-inch ASME B31.4/B31.8/CSA Z662 Cat. II ASME BVPC Sec. VIII Div. 1 U-Stamp (Head)

Size (in)	Part Numbers	Hinge Orientation	Wall Thickness	Nitrile	Low-Temp Nitrile	FKM	Low-Temp FKM
32	12361736	RH	1.000in	19-3700-3068-50	19-3700-3068-51	19-3700-3068-53	19-3700-3068-55
32	12361737	RH	.875in	19-3700-3068-50	19-3700-3068-51	19-3700-3068-53	19-3700-3068-55
32	12361738	RH	.750in	19-3700-3068-50	19-3700-3068-51	19-3700-3068-53	19-3700-3068-55
32	12361739	RH	.625in	19-3700-3068-50	19-3700-3068-51	19-3700-3068-53	19-3700-3068-55
32	12361740	RH	.500in	19-3700-3068-50	19-3700-3068-51	19-3700-3068-53	19-3700-3068-55
32	12361741	RH	.375in	19-3700-3068-50	19-3700-3068-51	19-3700-3068-53	19-3700-3068-55
32	12362970	RH	.250in	19-3700-3068-50	19-3700-3068-51	19-3700-3068-53	19-3700-3068-55
32	12361748	LH	1.000in	19-3700-3068-50	19-3700-3068-51	19-3700-3068-53	19-3700-3068-55
32	12361749	LH	.875in	19-3700-3068-50	19-3700-3068-51	19-3700-3068-53	19-3700-3068-55
32	12361750	LH	.750in	19-3700-3068-50	19-3700-3068-51	19-3700-3068-53	19-3700-3068-55
32	12361751	LH	.625in	19-3700-3068-50	19-3700-3068-51	19-3700-3068-53	19-3700-3068-55
32	12361752	LH	.500in	19-3700-3068-50	19-3700-3068-51	19-3700-3068-53	19-3700-3068-55
32	12361753	LH	.375in	19-3700-3068-50	19-3700-3068-51	19-3700-3068-53	19-3700-3068-55
32	12362972	LH	.250in	19-3700-3068-50	19-3700-3068-51	19-3700-3068-53	19-3700-3068-55
32	12363247*	RH		19-3700-3068-50	19-3700-3068-51	19-3700-3068-53	19-3700-3068-55
32	12363249*	LH		19-3700-3068-50	19-3700-3068-51	19-3700-3068-53	19-3700-3068-55

NOTICE: See additional O-ring part number tables for common O-ring options (must be ordered separately). Other O-ring materials are also available on a special-order basis.

Dimensions and Weights

Size	Wt (Lbs)	H x W x L
32	2743	17 x 54 x 70

* Flanged
Maximum test pressure is 1.5 times design pressure.

Dimensions and Part Numbers



T.D. Williamson

5100.005 - p12

34-inch

ASME B31.4/B31.8/CSA Z662 Cat. II

ASME BVPC Sec. VIII Div. 1 U-Stamp (Head)

Size (in)	Part Number	Hinge Orientation	Wall Thickness	Nitrile	Low-Temp Nitrile	FKM	Low-Temp FKM
34	12361760	RH	1.000in	19-3700-3250-50	19-3700-3250-51	19-3700-3250-53	19-3700-3250-55
34	12361761	RH	.875in	19-3700-3250-50	19-3700-3250-51	19-3700-3250-53	19-3700-3250-55
34	12361762	RH	.750in	19-3700-3250-50	19-3700-3250-51	19-3700-3250-53	19-3700-3250-55
34	12361763	RH	.625in	19-3700-3250-50	19-3700-3250-51	19-3700-3250-53	19-3700-3250-55
34	12361764	RH	.500in	19-3700-3250-50	19-3700-3250-51	19-3700-3250-53	19-3700-3250-55
34	12361765	RH	.375in	19-3700-3250-50	19-3700-3250-51	19-3700-3250-53	19-3700-3250-55
34	12361772	LH	1.000in	19-3700-3250-50	19-3700-3250-51	19-3700-3250-53	19-3700-3250-55
34	12361773	LH	.875in	19-3700-3250-50	19-3700-3250-51	19-3700-3250-53	19-3700-3250-55
34	12361774	LH	.750in	19-3700-3250-50	19-3700-3250-51	19-3700-3250-53	19-3700-3250-55
34	12361775	LH	.625in	19-3700-3250-50	19-3700-3250-51	19-3700-3250-53	19-3700-3250-55
34	12361776	LH	.500in	19-3700-3250-50	19-3700-3250-51	19-3700-3250-53	19-3700-3250-55
34	12361777	LH	.375in	19-3700-3250-50	19-3700-3250-51	19-3700-3250-53	19-3700-3250-55
34	12362968	LH	.250in	19-3700-3250-50	19-3700-3250-51	19-3700-3250-53	19-3700-3250-55
34	12363251*	RH		19-3700-3250-50	19-3700-3250-51	19-3700-3250-53	19-3700-3250-55
34	12363253*	LH		19-3700-3250-50	19-3700-3250-51	19-3700-3250-53	19-3700-3250-55

Dimensions and Weights

Size	Wt (Lbs)	H x W x L
34	3087	18 x 56 x 73

* Flanged

Maximum test pressure is 1.5 times design pressure.

Dimensions and Part Numbers



T.D. Williamson

5100.005 - p13

36-inch ASME B31.4/B31.8/CSA Z662 Cat. II ASME BVPC Sec. VIII Div. 1 U-Stamp (Head)

Size (in)	Part Number	Hinge Orientation	Wall Thickness	Nitrile	Low-Temp Nitrile	FKM	Low-Temp FKM
36	12351954	RH	1.125in	19-3700-3432-50	19-3700-3432-51	19-3700-3432-53	19-3700-3432-55
36	12356003	RH	1.000in	19-3700-3432-50	19-3700-3432-51	19-3700-3432-53	19-3700-3432-55
36	12355829	RH	.875in	19-3700-3432-50	19-3700-3432-51	19-3700-3432-53	19-3700-3432-55
36	12355830	RH	.750in	19-3700-3432-50	19-3700-3432-51	19-3700-3432-53	19-3700-3432-55
36	12355831	RH	.625in	19-3700-3432-50	19-3700-3432-51	19-3700-3432-53	19-3700-3432-55
36	12355832	RH	.500in	19-3700-3432-50	19-3700-3432-51	19-3700-3432-53	19-3700-3432-55
36	12355833	RH	.375in	19-3700-3432-50	19-3700-3432-51	19-3700-3432-53	19-3700-3432-55
36	12355840	LH	1.125in	19-3700-3432-50	19-3700-3432-51	19-3700-3432-53	19-3700-3432-55
36	12356008	LH	1.000in	19-3700-3432-50	19-3700-3432-51	19-3700-3432-53	19-3700-3432-55
36	12355841	LH	.875in	19-3700-3432-50	19-3700-3432-51	19-3700-3432-53	19-3700-3432-55
36	12355842	LH	.750in	19-3700-3432-50	19-3700-3432-51	19-3700-3432-53	19-3700-3432-55
36	12355843	LH	.625in	19-3700-3432-50	19-3700-3432-51	19-3700-3432-53	19-3700-3432-55
36	12355844	LH	.500in	19-3700-3432-50	19-3700-3432-51	19-3700-3432-53	19-3700-3432-55
36	12355845	LH	.375in	19-3700-3432-50	19-3700-3432-51	19-3700-3432-53	19-3700-3432-55
36	12363216*	RH		19-3700-3432-50	19-3700-3432-51	19-3700-3432-53	19-3700-3432-55
36	12363217*	LH		19-3700-3432-50	19-3700-3432-51	19-3700-3432-53	19-3700-3432-55

Dimensions and Weights

Size	Wt (Lbs)	H x W x L
36	3523	18 x 58 x 76

* Flanged
Maximum test pressure is
1.5 times design pressure.

Dimensions and Part Numbers

38-inch

ASME B31.4/B31.8/CSA Z662 Cat. II

ASME BVPC Sec. VIII Div. 1 U-Stamp (Head)



T.D. Williamson

5100.005 - p14

Size (in)	Part Number	Hinge Orientation	Wall Thickness	Nitrile	Low-Temp Nitrile	FKM	Low-Temp FKM
38	12363226	RH	1.250in	19-3700-3682-50	19-3700-3682-51	19-3700-3682-53	19-3700-3682-55
38	12361785	RH	1.125in	19-3700-3682-50	19-3700-3682-51	19-3700-3682-53	19-3700-3682-55
38	12361786	RH	1.000in	19-3700-3682-50	19-3700-3682-51	19-3700-3682-53	19-3700-3682-55
38	12361787	RH	.875in	19-3700-3682-50	19-3700-3682-51	19-3700-3682-53	19-3700-3682-55
38	12361788	RH	.750in	19-3700-3682-50	19-3700-3682-51	19-3700-3682-53	19-3700-3682-55
38	12361789	RH	.625in	19-3700-3682-50	19-3700-3682-51	19-3700-3682-53	19-3700-3682-55
38	12361790	RH	.500in	19-3700-3682-50	19-3700-3682-51	19-3700-3682-53	19-3700-3682-55
38	12361791	RH	.375in	19-3700-3682-50	19-3700-3682-51	19-3700-3682-53	19-3700-3682-55
38	12363224	LH	1.250in	19-3700-3682-50	19-3700-3682-51	19-3700-3682-53	19-3700-3682-55
38	12361799	LH	1.125in	19-3700-3682-50	19-3700-3682-51	19-3700-3682-53	19-3700-3682-55
38	12361800	LH	1.000in	19-3700-3682-50	19-3700-3682-51	19-3700-3682-53	19-3700-3682-55
38	12361801	LH	.875in	19-3700-3682-50	19-3700-3682-51	19-3700-3682-53	19-3700-3682-55
38	12361802	LH	.750in	19-3700-3682-50	19-3700-3682-51	19-3700-3682-53	19-3700-3682-55
38	12361803	LH	.625in	19-3700-3682-50	19-3700-3682-51	19-3700-3682-53	19-3700-3682-55
38	12361804	LH	.500in	19-3700-3682-50	19-3700-3682-51	19-3700-3682-53	19-3700-3682-55
38	12361805	LH	.375in	19-3700-3682-50	19-3700-3682-51	19-3700-3682-53	19-3700-3682-55
38	12363255*	RH		19-3700-3682-50	19-3700-3682-51	19-3700-3682-53	19-3700-3682-55
38	12363257*	LH		19-3700-3682-50	19-3700-3682-51	19-3700-3682-53	19-3700-3682-55

Dimensions and Weights

Size	Wt (Lbs)	H x W x L
38	4341	20 x 61 x 79

* Flanged
Maximum test pressure is
1.5 times design pressure.

Dimensions and Part Numbers



T.D. Williamson

5100.005 - p15

40-inch ASME B31.4/B31.8/CSA Z662 Cat. II ASME BVPC Sec. VIII Div. 1 U-Stamp (Head)

Size (in)	Part Number	Hinge Orientation	Wall Thickness	Nitrile	Low-Temp Nitrile	FKM	Low-Temp FKM
40	12361813	RH	1.250in	19-3700-3864-50	19-3700-3864-51	19-3700-3864-53	19-3700-3864-55
40	12361814	RH	1.125in	19-3700-3864-50	19-3700-3864-51	19-3700-3864-53	19-3700-3864-55
40	12361815	RH	1.000in	19-3700-3864-50	19-3700-3864-51	19-3700-3864-53	19-3700-3864-55
40	12361816	RH	.875in	19-3700-3864-50	19-3700-3864-51	19-3700-3864-53	19-3700-3864-55
40	12361817	RH	.750in	19-3700-3864-50	19-3700-3864-51	19-3700-3864-53	19-3700-3864-55
40	12361818	RH	.625in	19-3700-3864-50	19-3700-3864-51	19-3700-3864-53	19-3700-3864-55
40	12361819	RH	.500in	19-3700-3864-50	19-3700-3864-51	19-3700-3864-53	19-3700-3864-55
40	12363213	RH	.375in	19-3700-3864-50	19-3700-3864-51	19-3700-3864-53	19-3700-3864-55
40	12361827	LH	1.250in	19-3700-3864-50	19-3700-3864-51	19-3700-3864-53	19-3700-3864-55
40	12361828	LH	1.125in	19-3700-3864-50	19-3700-3864-51	19-3700-3864-53	19-3700-3864-55
40	12361829	LH	1.000in	19-3700-3864-50	19-3700-3864-51	19-3700-3864-53	19-3700-3864-55
40	12361830	LH	.875in	19-3700-3864-50	19-3700-3864-51	19-3700-3864-53	19-3700-3864-55
40	12361831	LH	.750in	19-3700-3864-50	19-3700-3864-51	19-3700-3864-53	19-3700-3864-55
40	12361832	LH	.625in	19-3700-3864-50	19-3700-3864-51	19-3700-3864-53	19-3700-3864-55
40	12361833	LH	.500in	19-3700-3864-50	19-3700-3864-51	19-3700-3864-53	19-3700-3864-55
40	12363215	LH	.375in	19-3700-3864-50	19-3700-3864-51	19-3700-3864-53	19-3700-3864-55
40	12363259*	RH		19-3700-3864-50	19-3700-3864-51	19-3700-3864-53	19-3700-3864-55
40	12363261*	LH		19-3700-3864-50	19-3700-3864-51	19-3700-3864-53	19-3700-3864-55

Dimensions and Weights

Size	Wt (Lbs)	H x W x L
40	4895	21 x 63 x 81

* Flanged
Maximum test pressure is
1.5 times design pressure.

Dimensions and Part Numbers



T.D. Williamson

5100.005 - p16

42-inch

ASME B31.4/B31.8/CSA Z662 Cat. II

ASME BVPC Sec. VIII Div. 1 U-Stamp (Head)

Dimensions and Weights

Size	Wt (Lbs)	H x W x L
42	5040	20 x 66 x 83

* Flanged
Maximum test pressure is
1.5 times design pressure.

Size (in)	Part Number	Hinge Orientation	Wall Thickness	Nitrile	Low-Temp Nitrile	FKM	Low-Temp FKM
42	12353623	RH	1.250in	19-3700-4023-50	19-3700-4023-51	19-3700-4023-53	19-3700-4023-55
42	12353624	RH	1.125in	19-3700-4023-50	19-3700-4023-51	19-3700-4023-53	19-3700-4023-55
42	12353625	RH	1.000in	19-3700-4023-50	19-3700-4023-51	19-3700-4023-53	19-3700-4023-55
42	12353626	RH	.875in	19-3700-4023-50	19-3700-4023-51	19-3700-4023-53	19-3700-4023-55
42	12353627	RH	.750in	19-3700-4023-50	19-3700-4023-51	19-3700-4023-53	19-3700-4023-55
42	12353628	RH	.625in	19-3700-4023-50	19-3700-4023-51	19-3700-4023-53	19-3700-4023-55
42	12353629	RH	.500in	19-3700-4023-50	19-3700-4023-51	19-3700-4023-53	19-3700-4023-55
42	12362814	RH	.375in	19-3700-4023-50	19-3700-4023-51	19-3700-4023-53	19-3700-4023-55
42	12356286	LH	1.250in	19-3700-4023-50	19-3700-4023-51	19-3700-4023-53	19-3700-4023-55
42	12356287	LH	1.125in	19-3700-4023-50	19-3700-4023-51	19-3700-4023-53	19-3700-4023-55
42	12356288	LH	1.000in	19-3700-4023-50	19-3700-4023-51	19-3700-4023-53	19-3700-4023-55
42	12356289	LH	.875in	19-3700-4023-50	19-3700-4023-51	19-3700-4023-53	19-3700-4023-55
42	12356290	LH	.750in	19-3700-4023-50	19-3700-4023-51	19-3700-4023-53	19-3700-4023-55
42	12356291	LH	.625in	19-3700-4023-50	19-3700-4023-51	19-3700-4023-53	19-3700-4023-55
42	12356292	LH	.500in	19-3700-4023-50	19-3700-4023-51	19-3700-4023-53	19-3700-4023-55
42	12362855	LH	.375in	19-3700-4023-50	19-3700-4023-51	19-3700-4023-53	19-3700-4023-55
42	12361343*	RH		19-3700-4023-50	19-3700-4023-51	19-3700-4023-53	19-3700-4023-55
42	12361344*	LH		19-3700-4023-50	19-3700-4023-51	19-3700-4023-53	19-3700-4023-55

Dimensions and Part Numbers



T.D. Williamson

5100.005 - p17

44-inch ASME B31.4/B31.8/CSA Z662 Cat. II ASME BVPC Sec. VIII Div. 1 U-Stamp (Head)

Dimensions and Weights

Size	Wt (Lbs)	H x W x L
44	5975	21 x 68 x 85

* Flanged
Maximum test pressure is
1.5 times design pressure.

Size (in)	Part Number	Hinge Orientation	Wall Thickness	Nitrile	Low-Temp Nitrile	FKM	Low-Temp FKM
44	12359087	RH	1.125in	19-3700-4227-50	19-3700-4227-51	19-3700-4227-53	19-3700-4227-55
44	12359088	RH	1.000in	19-3700-4227-50	19-3700-4227-51	19-3700-4227-53	19-3700-4227-55
44	12359089	RH	.875in	19-3700-4227-50	19-3700-4227-51	19-3700-4227-53	19-3700-4227-55
44	12359090	RH	.750in	19-3700-4227-50	19-3700-4227-51	19-3700-4227-53	19-3700-4227-55
44	12359091	RH	.625in	19-3700-4227-50	19-3700-4227-51	19-3700-4227-53	19-3700-4227-55
44	12359092	RH	.500in	19-3700-4227-50	19-3700-4227-51	19-3700-4227-53	19-3700-4227-55
44	12359093	RH	.375in	19-3700-4227-50	19-3700-4227-51	19-3700-4227-53	19-3700-4227-55
44	12366082	RH	.250in	19-3700-4227-50	19-3700-4227-51	19-3700-4227-53	19-3700-4227-55
44	12361841	LH	1.125in	19-3700-4227-50	19-3700-4227-51	19-3700-4227-53	19-3700-4227-55
44	12361842	LH	1.000in	19-3700-4227-50	19-3700-4227-51	19-3700-4227-53	19-3700-4227-55
44	12361843	LH	.875in	19-3700-4227-50	19-3700-4227-51	19-3700-4227-53	19-3700-4227-55
44	12361844	LH	.750in	19-3700-4227-50	19-3700-4227-51	19-3700-4227-53	19-3700-4227-55
44	12361845	LH	.625in	19-3700-4227-50	19-3700-4227-51	19-3700-4227-53	19-3700-4227-55
44	12361846	LH	.500in	19-3700-4227-50	19-3700-4227-51	19-3700-4227-53	19-3700-4227-55
44	12361847	LH	.375in	19-3700-4227-50	19-3700-4227-51	19-3700-4227-53	19-3700-4227-55
44	12366084	LH	.250in	19-3700-4227-50	19-3700-4227-51	19-3700-4227-53	19-3700-4227-55
44	12363263*	RH		19-3700-4409-50	19-3700-4409-51	19-3700-4409-53	19-3700-4409-55
44	12363265*	LH		19-3700-4409-50	19-3700-4409-51	19-3700-4409-53	19-3700-4409-55

Dimensions and Part Numbers



T.D. Williamson
5100.005 - p18

46-inch

ASME B31.4/B31.8/CSA Z662 Cat. II

ASME BVPC Sec. VIII Div. 1 U-Stamp (Head)

Dimensions and Weights

Size	Wt (Lbs)	H x W x L
46	6742	22 x 70 x 87

* Flanged

Maximum test pressure is
1.5 times design pressure.

Size (in)	Part Number	Hinge Orientation	Wall Thickness	Nitrile	Low-Temp Nitrile	FKM	Low-Temp FKM
46	12361855	RH	1.250in	19-3700-4409-50	19-3700-4409-51	19-3700-4409-53	19-3700-4409-55
46	12361856	RH	1.125in	19-3700-4409-50	19-3700-4409-51	19-3700-4409-53	19-3700-4409-55
46	12361857	RH	1.000in	19-3700-4409-50	19-3700-4409-51	19-3700-4409-53	19-3700-4409-55
46	12361858	RH	.875in	19-3700-4409-50	19-3700-4409-51	19-3700-4409-53	19-3700-4409-55
46	12361859	RH	.750in	19-3700-4409-50	19-3700-4409-51	19-3700-4409-53	19-3700-4409-55
46	12361860	RH	.625in	19-3700-4409-50	19-3700-4409-51	19-3700-4409-53	19-3700-4409-55
46	12361861	RH	.500in	19-3700-4409-50	19-3700-4409-51	19-3700-4409-53	19-3700-4409-55
46	12362962	RH	.375in	19-3700-4409-50	19-3700-4409-51	19-3700-4409-53	19-3700-4409-55
46	12361869	LH	1.250in	19-3700-4409-50	19-3700-4409-51	19-3700-4409-53	19-3700-4409-55
46	12361870	LH	1.125in	19-3700-4409-50	19-3700-4409-51	19-3700-4409-53	19-3700-4409-55
46	12361871	LH	1.000in	19-3700-4409-50	19-3700-4409-51	19-3700-4409-53	19-3700-4409-55
46	12361872	LH	.875in	19-3700-4409-50	19-3700-4409-51	19-3700-4409-53	19-3700-4409-55
46	12361873	LH	.750in	19-3700-4409-50	19-3700-4409-51	19-3700-4409-53	19-3700-4409-55
46	12361874	LH	.625in	19-3700-4409-50	19-3700-4409-51	19-3700-4409-53	19-3700-4409-55
46	12361875	LH	.500in	19-3700-4409-50	19-3700-4409-51	19-3700-4409-53	19-3700-4409-55
46	12362964	LH	.375in	19-3700-4409-50	19-3700-4409-51	19-3700-4409-53	19-3700-4409-55
46	12363267*	RH		19-3700-4591-50	19-3700-4591-51	19-3700-4591-53	19-3700-4591-55
46	12363269*	LH		19-3700-4591-50	19-3700-4591-51	19-3700-4591-53	19-3700-4591-55

Dimensions and Part Numbers

48-inch

ASME B31.4/B31.8/CSA Z662 Cat. II

ASME BVPC Sec. VIII Div. 1 U-Stamp (Head)



T.D. Williamson

5100.005 - p19

Dimensions and Weights

Size	Wt (Lbs)	H x W x L
48	7137	22 x 73 x 90

* Flanged
Maximum test pressure is
1.5 times design pressure.

Size (in)	Part Number	Hinge Orientation	Wall Thickness	Nitrile	Low-Temp Nitrile	FKM	Low-Temp FKM
48	12361883	RH	1.250in	19-3700-4591-50	19-3700-4591-51	19-3700-4591-53	19-3700-4591-55
48	12361884	RH	1.125in	19-3700-4591-50	19-3700-4591-51	19-3700-4591-53	19-3700-4591-55
48	12361885	RH	1.000in	19-3700-4591-50	19-3700-4591-51	19-3700-4591-53	19-3700-4591-55
48	12361886	RH	.875in	19-3700-4591-50	19-3700-4591-51	19-3700-4591-53	19-3700-4591-55
48	12361887	RH	.750in	19-3700-4591-50	19-3700-4591-51	19-3700-4591-53	19-3700-4591-55
48	12361888	RH	.625in	19-3700-4591-50	19-3700-4591-51	19-3700-4591-53	19-3700-4591-55
48	12361889	RH	.500in	19-3700-4591-50	19-3700-4591-51	19-3700-4591-53	19-3700-4591-55
48	12363117	RH	.375in	19-3700-4591-50	19-3700-4591-51	19-3700-4591-53	19-3700-4591-55
48	12361899	LH	1.250in	19-3700-4591-50	19-3700-4591-51	19-3700-4591-53	19-3700-4591-55
48	12361900	LH	1.125in	19-3700-4591-50	19-3700-4591-51	19-3700-4591-53	19-3700-4591-55
48	12361901	LH	1.000in	19-3700-4591-50	19-3700-4591-51	19-3700-4591-53	19-3700-4591-55
48	12361902	LH	.875in	19-3700-4591-50	19-3700-4591-51	19-3700-4591-53	19-3700-4591-55
48	12361903	LH	.750in	19-3700-4591-50	19-3700-4591-51	19-3700-4591-53	19-3700-4591-55
48	12361904	LH	.625in	19-3700-4591-50	19-3700-4591-51	19-3700-4591-53	19-3700-4591-55
48	12361905	LH	.500in	19-3700-4591-50	19-3700-4591-51	19-3700-4591-53	19-3700-4591-55
48	12363114	LH	.375in	19-3700-4591-50	19-3700-4591-51	19-3700-4591-53	19-3700-4591-55
48	12363271*	RH		19-3700-4591-50	19-3700-4591-51	19-3700-4591-53	19-3700-4591-55
48	12363273*	LH		19-3700-4591-50	19-3700-4591-51	19-3700-4591-53	19-3700-4591-55

Dimensions and Part Numbers



T.D. Williamson

5100.005 - p20