



VANTAGE® V Batching Pig

Sizes: 10-inch and larger



T.D. Williamson

Bulletin No: 3000.006.04
Version: 01.2007
Cross Indexing No: n/a
Supersedes: 3000.006.03 (04.2004)



■ **3D2CC VANTAGE® V Batching Pig**
with RealSeal® Cups
(10-inch size shown)



■ **5D2CC VANTAGE® V Batching Pig**
(12-inch size shown)

Description

VANTAGE® V Batching Pigs are multi-use pigs designed for batching, displacing and light cleaning of pipelines 10-inch and larger. Two- and four-cup configurations can be provided, as well as a disc/cup configuration.

The basic two-cup configuration will satisfy most new construction batching/displacing applications. A four-cup or disc/cup design is recommended for:

- Batching products with critical interface contamination points
- Displacing liquids on excessively long runs
- Traversing long-bowl checks and wedge gate valves.

The conical cup features a large wear surface, a cone shape and a small bolt circle. Cups and discs provide excellent sealing capabilities and flexibility. The pig is designed to traverse 20 percent reductions due to anomalies in the pipe without damaging the pipe or pig.

Features

The disc/cup configuration allows for additional batching and light cleaning. The disc also adds support to the pig, increasing the cup life.

All cups and discs are replaceable and can be interchanged or reconfigured. The VANTAGE V Batching Pig is rugged and easy to maintain. It features a consistent design throughout the size range and is available in several different standard configurations to meet most pigging applications.

The VANTAGE V Pigs are equipped with non-metallic bumpers to protect the bolts and prevent metal to metal contact during pigging operations.

Options

T.D. Williamson, Inc., is committed to providing you with the exact product to assist you in meeting your individual needs. The VANTAGE V Batching Pig is offered in several configurations.

- Two- or four-cup and disc-cup configurations can be provided.
- It is available in sizes 10-inch and larger.
- It may be equipped with a magnet kit to remove ferrous debris.
- It may be equipped with an adapter plate on which to mount a pig tracking transmitter.
- It may be equipped with dual diameter cups.
- RealSeal® Multi-Lip cups are available for increased seal effectiveness and wear life.

RealSeal® Multi-Lip Cup: Patented in the United States and in foreign countries.

North and South America: 918-447-5400

Europe / Africa: 32-67-28-04-20

Middle East: 91-2667-619900

Asia / Pacific: 65-6364-8520



VANTAGE® V Batching Pigs

2CC Configuration

The 2CC VANTAGE® V Batching Pigs are recommended for light to medium batching and in lines with 1.5 DR - 90° bends.

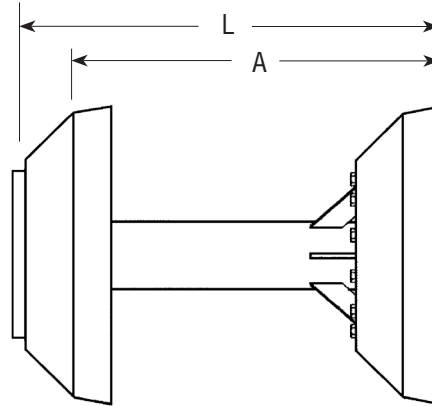

Size		Part Number	Weight		Allowable Pipe ID Variations				A		L	
Inch	mm		Lbs.	Kg.	Minimum		Maximum		Inch	mm	Inch	mm
10	250	01-1970-0010	18	8	9-3/4	246	10-1/2	266	14-9/16	370	19-11/16	500
12	300	01-1970-0012	23	10	11-3/4	300	12-1/2	317	14-7/16	367	20-9/16	522
14	350	01-1970-0014	24	11	13	330	13-3/4	349	14-1/2	368	21-1/4	540
16	400	01-1299-0000	42	19	14-3/4	375	15-5/8	397	20-1/2	521	23-9/16	598
18	450	01-1300-0000	68	31	16-3/4	425	17-5/8	448	24-1/4	616	27-3/8	695
20	500	01-1301-0000	75	34	18-3/4	476	19-5/8	498	24-1/2	622	28-5/8	727
22	550	01-1302-0000	129	58	20-1/2	521	21-3/4	552	29-1/4	743	32-5/8	829
24	600	01-1303-0000	139	63	22-1/2	572	23-3/4	603	29-1/2	749	33-7/8	860
26	650	01-1304-0000	165	74	24-1/2	622	25-3/4	654	34	864	38-7/16	976
28	700	01-1305-0000	177	80	26-1/2	673	27-3/4	705	34-1/4	870	39-11/16	1008
30	750	01-1306-0000	260	117	28-1/4	718	29-3/4	756	39-3/4	1010	44-1/2	1130
32	800	01-1307-0000	280	126	30-1/4	768	31-3/4	806	40	1016	45-3/4	1162
34	850	01-1308-0000	375	169	32-1/4	819	33-3/4	857	46-1/4	1175	51-1/2	1308
36	900	01-1309-0000	399	180	34-1/4	870	35-3/4	908	46-1/2	1181	52-7/8	1343
40	1000	01-1310-0000	638	287	38	965	39-3/4	1010	52-3/4	1340	58-7/8	1495
42	1050	01-1311-0000	664	299	40	1016	41-3/4	1060	53	1346	60-1/8	1527

Consult the factory for larger sizes.



VANTAGE® V Batching Pigs

4CC Configuration

The 4CC VANTAGE® V Batching Pigs are recommended for medium to heavy batching and lines with 1.5 DR - 90° bends. This pig will traverse most long-bowl check valves and full-opening wedge gate valves.

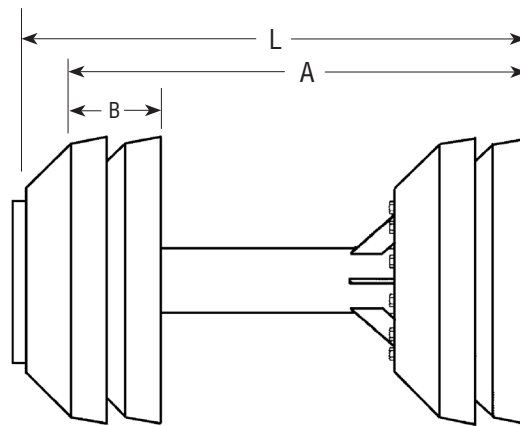

Size		Part Number	Weight		Allowable Pipe ID Variations				A		B		L	
Inch	mm		Lbs.	Kg.	Minimum		Maximum		Inch	mm	Inch	mm	Inch	mm
10	250	01-1972-0010	24	11	9-3/4	246	10-1/2	266	16-11/16	424	4-1/16	103	21-1/16	535
12	300	01-1972-0012	34	15	11-3/4	300	12-1/2	317	20-9/16	522	4-7/16	113	26-11/16	678
14	350	01-1972-0014	36	16	13	330	13-3/4	349	20-5/8	524	4-1/2	114	27-3/8	695
16	400	01-1379-0000	74	34	14-3/4	375	15-5/8	397	27	686	5-1/4	133	29-1/16	738
18	450	01-1380-0000	126	57	16-3/4	425	17-5/8	448	31-3/4	806	6	152	33-7/8	860
20	500	01-1381-0000	127	58	18-3/4	476	19-5/8	498	32	813	6-1/4	159	35-1/8	892
22	550	01-1382-0000	223	101	20-1/2	521	21-3/4	552	38-1/2	978	7-3/8	187	41-3/16	1046
24	600	01-1383-0000	243	110	22-1/2	572	23-3/4	603	38	984	7-5/8	194	42-7/16	1078
26	650	01-1384-0000	287	130	24-1/2	622	25-3/4	654	44-1/4	1124	8-3/8	213	47-15/16	1218
28	700	01-1385-0000	311	141	26-1/2	673	27-3/4	705	44-1/2	1130	8-5/8	219	49-3/16	1249
30	750	01-1386-0000	426	193	28-1/4	718	29-3/4	756	51-1/4	1302	9-1/2	241	55-3/8	1406
32	800	01-1387-0000	446	202	30-1/4	768	31-3/4	806	51-1/2	1308	9-3/4	248	56-5/8	1438
34	850	01-1388-0000	613	278	32-1/4	819	33-3/4	857	59-1/4	1505	10-3/4	273	64-1/8	1629
36	900	01-1389-0000	661	300	34-1/4	870	35-3/4	908	59-1/2	1511	11	279	65-1/2	1664
40	1000	01-1390-0000	1026	465	38	965	39-3/4	1010	67-3/4	1721	12-1/2	318	73-1/2	1867
42	1050	01-1391-0000	1078	489	40	1016	41-3/4	1060	68	1727	12-3/4	324	74-3/4	1899

Consult the factory for larger sizes.



VANTAGE® V Batching Pigs

The DCDC VANTAGE® V Batching Pigs are recommended for medium to heavy batching. The pigs will traverse 1.5 DR - 90° bends. This pig will traverse most long bowl check valves and full-opening wedge gate valves.

DCDC Configuration

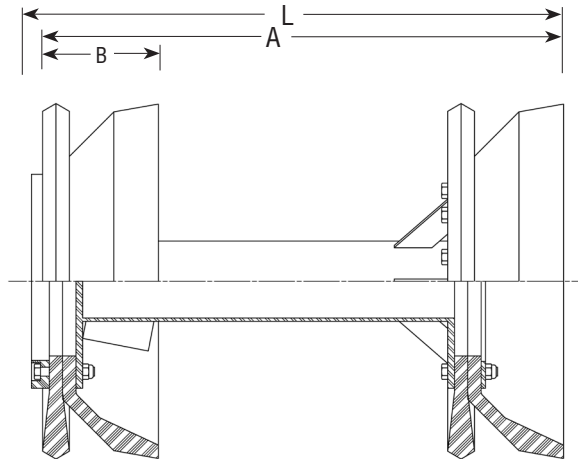

Size		Part Number	Weight		Allowable Pipe ID Variations				A		B		L	
Inch	mm		Lbs.	Kg.	Minimum		Maximum		Inch	mm	Inch	mm	Inch	mm
10	250	01-1633-0010	19	9	9-3/4	246	10-1/2	266	14-11/16	373	3-3/4	95	18-7/16	468
12	300	01-1633-0012	27	12	11-3/4	300	12-1/2	317	18-9/16	471	4-5/8	117	22-5/16	567
14	350	01-1633-0014	30	14	13	330	13-3/4	349	19-1/4	489	5-5/16	135	23	584
16	400	01-1633-0016	62	28	14-3/4	375	15-5/8	397	23-15/16	608	4-7/16	113	24-11/16	627
18	450	01-1633-0018	92	42	16-3/4	425	17-5/8	448	27-3/4	705	4-3/4	121	28-1/2	724
20	500	01-1633-0020	105	48	18-3/4	476	19-5/8	498	29	737	5-7/8	149	29-3/4	756
22	550	01-1633-0022	170	77	20-1/2	521	21-3/4	552	33-5/8	854	6	152	34-1/2	876
24	600	01-1633-0024	190	86	22-1/2	572	23-3/4	603	34-7/8	886	7-1/8	181	35-3/4	908
26	650	01-1633-0026	230	104	24-1/2	622	25-3/4	654	39-3/8	1000	7-3/8	187	40-1/4	1022
28	700	01-1633-0028	250	113	26-1/2	673	27-3/4	705	40-5/8	1032	8-3/8	213	41-1/2	1054
30	750	01-1633-0030	345	156	28-1/4	718	29-3/4	756	45-3/4	1162	8-5/8	219	46-3/4	1187
32	800	01-1633-0032	380	172	30-1/4	768	31-3/4	806	47	1194	9-5/8	244	48	1219
34	850	01-1633-0034	505	229	32-1/4	819	33-3/4	857	53-3/8	1356	9-3/4	248	54-5/8	1387
36	900	01-1633-0036	555	252	34-1/4	870	35-3/4	908	54-3/4	1391	11-1/8	283	56	1422
40	1000	01-1633-0040	845	383	38	965	39-3/4	1010	61-1/4	1556	11-1/2	292	62-3/4	1594
42	1050	01-1633-0042	905	411	40	1016	41-3/4	1060	62-1/2	1588	12-3/4	324	64	1626

Consult the factory for larger sizes.



VANTAGE® V Batching Pigs

3D2CC Configuration

The 3D2CC VANTAGE® V Batching Pigs are recommended for medium to heavy batching and lines with 1.5 DR - 90° bends. This pig will traverse most long-bowl check valves and full-opening wedge gate valves.

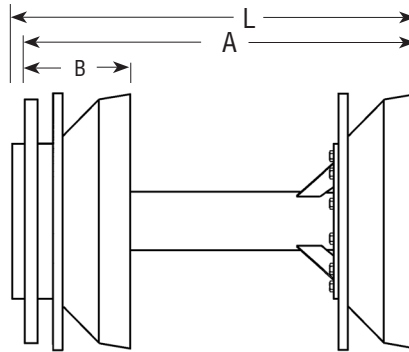

Allowable Pipe ID Variations

Size		Part Number	Weight		Minimum		Maximum		A		B		L	
Inch	mm		Lbs.	Kg.	Inch	mm	Inch	mm	Inch	mm	Inch	mm	Inch	mm
10	250	01-1772-0010	20	9	9-3/4	246	10-1/2	266	15-1/16	382	4-5/8	117	18-7/16	468
12	300	01-1772-0012	32	15	11-3/4	300	12-1/2	317	19-7/16	494	5-7/8	149	22-13/16	579
14	350	01-1772-0014	35	16	13	330	13-3/4	349	20-1/8	511	6-9/16	167	23-1/2	597
16	400	01-1772-0016	52	25	14-3/4	375	15-5/8	397	25-7/16	646	6-5/16	160	26-7/16	672
18	450	01-1772-0018	89	40	16-3/4	425	17-5/8	448	29-1/2	749	6-7/8	175	30-1/2	775
20	500	01-1772-0020	101	46	18-3/4	476	19-5/8	498	31-1/8	791	8-3/8	213	32-1/8	816
22	550	01-1772-0022	160	73	20-1/2	521	21-3/4	552	35-5/16	897	8-1/16	205	36-9/16	929
24	600	01-1772-0024	190	89	22-1/2	572	23-3/4	603	37-1/16	941	9-11/16	246	38-5/16	972
26	650	01-1772-0026	211	96	24-1/2	622	25-3/4	654	41-9/16	1056	9-15/16	252	42-13/16	1087
28	700	01-1772-0028	266	121	26-1/2	673	27-3/4	705	43-9/16	1106	11-11/16	297	44-13/16	1138
30	750	01-1772-0030	353	160	28-1/4	718	29-3/4	756	48-3/8	1229	11-3/8	289	49-5/8	1260
32	800	01-1772-0032	394	179	30-1/4	768	31-3/4	806	50	1270	12-7/8	327	51-1/4	1302
34	850	01-1772-0034	475	215	32-1/4	819	33-3/4	857	56-1/4	1429	13-1/8	333	57-1/2	1461
36	900	01-1772-0036	561	254	34-1/4	870	35-3/4	908	58-1/8	1476	14-7/8	378	59-3/8	1508
40	1000	01-1772-0040	826	375	38	965	39-3/4	1010	64-1/2	1638	15-3/8	391	65-3/4	1670
42	1050	01-1772-0042	919	417	40	1016	41-3/4	1060	66-1/4	1683	17	432	67-1/2	1715

Consult the factory for larger sizes.



VANTAGE® V Batching Pigs

5D2CC Configuration

The 5D2CC VANTAGE® V Batching Pigs are recommended for medium to heavy batching of lines with 1.5 DR - 90° bends. This pig will traverse most long-bowl check valves and full-opening wedge gate valves.

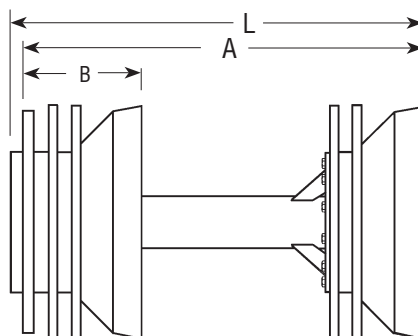

Allowable Pipe ID Variations

Size		Part Number	Weight		Minimum		Maximum		A		B		L	
Inch	mm		Lbs.	Kg.	Inch	mm	Inch	mm	Inch	mm	Inch	mm	Inch	mm
10	250	01-1773-0010	24	11	9-3/4	246	10-1/2	266	16-13/16	427	5-1/2	140	20-3/16	513
12	300	01-1773-0012	38	15	11-3/4	300	12-1/2	317	21-7/16	544	6-7/8	175	24-13/16	630
14	350	01-1773-0014	42	19	13	330	13-3/4	349	22-1/8	562	7-9/16	192	25-1/2	648
16	400	01-1773-0016	69	31	14-3/4	375	15-5/8	397	28-11/16	729	7-15/16	202	29-11/16	754
18	450	01-1773-0018	106	48	16-3/4	425	17-5/8	448	33-1/4	845	8-3/4	222	34-1/4	870
20	500	01-1773-0020	124	56	18-3/4	476	19-5/8	498	35-1/8	892	10-3/8	264	36-1/8	918
22	550	01-1773-0022	189	86	20-1/2	521	21-3/4	552	39-5/16	999	10-1/16	256	40-9/16	1030
24	600	01-1773-0024	228	103	22-1/2	572	23-3/4	603	41-5/16	1049	11-13/16	300	42-9/16	1081
26	650	01-1773-0026	254	115	24-1/2	622	25-3/4	654	45-13/16	1164	12-1/16	306	47-1/16	1195
28	700	01-1773-0028	325	147	26-1/2	673	27-3/4	705	48-5/16	1227	14-1/16	357	49-9/16	1259
30	750	01-1773-0030	417	189	28-1/4	718	29-3/4	756	53-3/8	1356	13-7/8	352	54-5/8	1387
32	800	01-1773-0032	473	215	30-1/4	768	31-3/4	806	55-1/4	1403	15-1/2	394	56-1/2	1435
34	850	01-1773-0034	565	256	32-1/4	819	33-3/4	857	62	1575	16	406	63-1/4	1607
36	900	01-1773-0036	670	304	34-1/4	870	35-3/4	908	64-1/8	1629	17-7/8	454	65-3/8	1661
40	1000	01-1773-0040	965	438	38	965	39-3/4	1010	71-1/4	1818	18-3/4	476	72-1/2	1842
42	1050	01-1773-0042	1083	491	40	1016	41-3/4	1060	73-1/4	1861	20-1/2	513	74-1/2	1892

Consult the factory for larger sizes.



VANTAGE® V Cleaning Pig

Sizes: 10-inch and larger



T.D. Williamson

Bulletin No: 3000.004.06

Version: 04.2011

Cross Indexing No: n/a

Supersedes: 3000.004.05 (02.2009)



■ DCDC-BR VANTAGE® V Cleaning Pig with brushes (12-inch size shown)



■ DCDC-BR VANTAGE® V Cleaning Pig with brushes and urethane nose bumper shown. (20-inch size shown)

Description

VANTAGE® V Cleaning Pigs are multi-use pigs equipped with either scraper discs/cups, cups, brushes or blade cleaning elements. The VANTAGE V is offered in eight different cleaning configurations. All cups and discs are replaceable and can be interchanged or reconfigured.

Features

All 16- through 42-inch VANTAGE V Pigs are equipped with a bypass hole option, which allows you to create a jetting action to improve cleaning effectiveness. Bypass ports can be provided on 10- to 14-inch sizes if requested. This pig is rugged and easy to maintain.

The conical cup features a large wear surface, a conical shape with a small bolt circle. The disc/cup configuration allows for additional cleaning. The disc adds additional support to the pig, increasing

the cup life. Cups and discs have excellent sealing capabilities and flexibility. The pig is designed to traverse 15 to 20 percent reductions due to anomalies in the pipe without damaging the pipe or pig.

Cleaning elements include brushes to remove hard, crust-like deposits, urethane blades for removing soft, gummy deposits, scraper discs to clean both hard and soft internal deposits, and magnet kits to remove ferrous material. All blades, brushes and scraper discs provide 100 percent circumferential cleaning.

The VANTAGE V pigs are equipped with non-metallic bumpers to protect the bolts and prevent metal-to-metal contact during pigging operations.

North and South America: 918-447-5400

Europe / Africa: 32-67-28-04-20

Middle East: 91-2667-619900

Asia / Pacific: 65-6364-8520

Options

T.D. Williamson, Inc. is committed to providing you with the exact product to assist you with your individual needs. The VANTAGE V Cleaning Pig is offered in eight configurations.

- Two-cup and several disc/cup configurations can be provided.
- Available in sizes 10-inch and larger
- May be equipped with a magnet kit to remove ferrous debris.
- May be equipped with gauge plates at a specified diameter and configuration.
- May be equipped with an adapter plate on which to mount a pig tracking transmitter.
- May be equipped with removable bypass plugs (standard on 16-inch and larger) to obtain jet cleaning.
- May be converted to a batching/displacement pig by removing the cleaning elements.
- RealSeal® multi-lip cups are available for increased seal effectiveness and wear life.



■ Close up of optional RealSeal® Multi-Lip Cup

RealSeal® Multi-Lip Cup: Patented in the United States and in foreign countries.

VANTAGE® V Cleaning Pigs

2CC Configurations

The 2CC VANTAGE® V Cleaning Pigs are recommended for light to medium cleaning and lines with 1.5 DR - 90° bends.

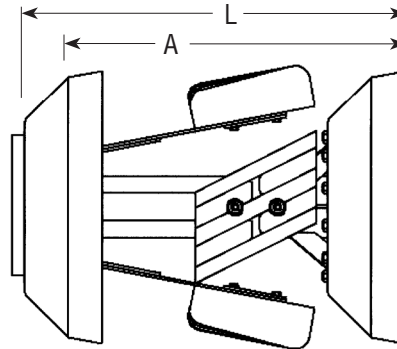

■ 2CC Blade Configuration

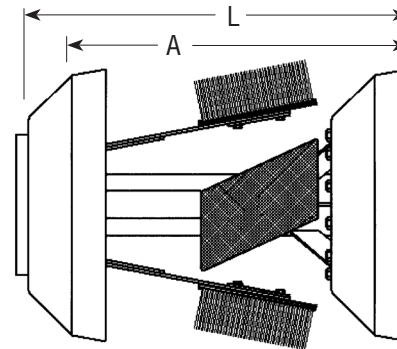

■ 2CC Brush Configuration

Size		2CC-BL Blade Cleaning Pig			2CC-BR Brush Cleaning Pig			2CC (Blade or Brush) Dimensions			
Inch	mm	Part Number	Weight		Part Number	Weight		A		L	
			Lbs.	Kg.		Lbs.	Kg.	Inch	mm	Inch	mm
10	250	02-3068-0010	28	13	02-3067-0010	33	15	14-9/16	370	19-11/16	500
12	300	02-3068-0012	33	15	02-3067-0012	38	17	16-11/16	424	20-9/16	522
14	350	02-3068-0014	36	16	02-3067-0014	41	19	16-3/4	425	21-1/4	540
16	400	02-2290-0000	72	33	02-2304-0000	74	34	20-1/2	521	23-9/16	598
18	450	02-2291-0000	110	50	02-2305-0000	130	59	24-1/4	616	27-3/8	695
20	500	02-2292-0000	118	54	02-2306-0000	147	67	24-1/2	622	28-5/8	727
22	550	02-2293-0000	195	88	02-2307-0000	214	97	29-1/4	743	32-5/8	829
24	600	02-2294-0000	207	94	02-2308-0000	234	106	29-1/2	749	33-7/8	860
26	650	02-2295-0000	250	113	02-2309-0000	281	127	34	864	38-7/16	976
28	700	02-2296-0000	265	120	02-2310-0000	308	140	34-1/4	870	39-11/16	1008
30	750	02-2297-0000	360	163	02-2311-0000	387	176	39-3/4	1010	44-1/2	1130
32	800	02-2298-0000	385	175	02-2312-0000	423	192	40	1016	45-3/4	1162
34	850	02-2299-0000	538	244	02-2313-0000	576	262	46-1/4	1175	51-1/2	1308
36	900	02-2300-0000	562	255	02-2314-0000	627	284	46-1/2	1181	52-7/8	1343
40	1000	02-2301-0000	820	372	02-2315-0000	857	388	52-3/4	1340	58-7/8	1495
42	1050	02-2302-0000	858	389	02-2316-0000	913	414	53	1346	60-1/8	1527

Consult the factory for larger sizes.

VANTAGE® V Cleaning Pigs

The 3D2CC VANTAGE® V Cleaning Pigs are recommended for medium to heavy cleaning. The 10- to 14-inch pigs will traverse 1.5 DR - 90° bends and the 16-inches and larger will traverse 3.0 DR - 90° bends. This pig will traverse most long bowl check valves and full opening wedge gate valves.

3D2CC Configurations

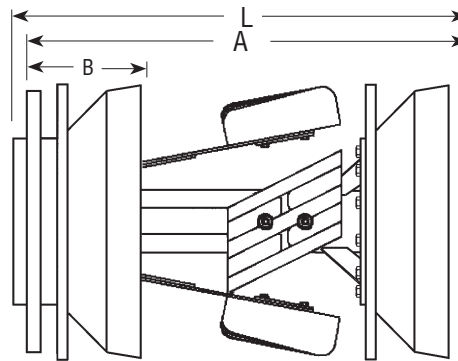

■ 3D2CC Blade Configuration

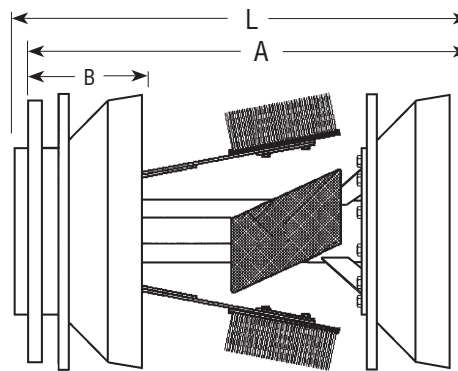

■ 3D2CC Brush Configuration

Size		3D2CC-BL Blade Cleaning Pig			3D2CC-BR Brush Cleaning Pig			3D2CC (Blade or Brush) Dimensions					
		Weight		Weight		Weight		A		B		L	
Inch	mm	Part Number	Lbs.	Kg.	Part Number	Lbs.	Kg.	Inch	mm	Inch	mm	Inch	mm
10	250	02-2953-0010	33	15	02-2954-0010	38	17	18-1/16	459	4-5/8	117	21-7/16	544
12	300	02-2953-0012	43	20	02-2954-0012	48	22	21-11/16	551	5-7/8	149	25-1/16	637
14	350	02-2953-0014	48	22	02-2954-0014	53	24	22-3/8	568	6-9/16	167	25-3/4	654
16	400	02-2953-0016	86	39	02-2954-0016	88	40	25-7/16	646	6-5/16	160	26-7/16	672
18	450	02-2953-0018	131	59	02-2954-0018	151	68	29-1/2	749	6-7/8	175	30-1/2	775
20	500	02-2953-0020	144	65	02-2954-0020	173	78	31-1/8	791	8-3/8	213	32-1/8	816
22	550	02-2953-0022	226	103	02-2954-0022	245	111	35-5/16	897	8-1/16	205	36-9/16	929
24	600	02-2953-0024	258	117	02-2954-0024	285	129	37-1/16	941	9-11/16	246	38-5/16	972
26	650	02-2953-0026	296	134	02-2954-0026	327	148	41-9/16	1056	9-15/16	252	42-13/16	1087
28	700	02-2953-0028	354	161	02-2954-0028	397	180	43-9/16	1106	11-11/16	297	44-13/16	1138
30	750	02-2953-0030	453	205	02-2954-0030	480	218	48-3/8	1229	11-3/8	289	49-5/8	1260
32	800	02-2953-0032	499	226	02-2954-0032	537	244	50	1270	12-7/8	327	51-1/4	1302
34	850	02-2953-0034	638	289	02-2954-0034	676	307	56-1/4	1429	13-1/8	333	57-1/2	1461
36	900	02-2953-0036	724	328	02-2954-0036	789	358	58-1/8	1476	14-7/8	378	59-3/8	1508
40	1000	02-2953-0040	1008	457	02-2954-0040	1045	474	64-1/2	1638	15-3/8	391	65-3/4	1670
42	1050	02-2953-0042	1113	505	02-2954-0042	1168	530	66-1/4	1683	17	432	67-1/2	1715

Consult the factory for larger sizes.



VANTAGE® V Cleaning Pigs

5D2CC Configuration

The 5D2CC VANTAGE® V Cleaning Pigs are recommended for medium to heavy cleaning. The 10- to 14-inch pigs will traverse 1.5 DR - 90° bends and 16-inches and larger will traverse 3.0 DR - 90° bends. This pig will traverse most long bowl check valves and full-opening wedge gate valves.

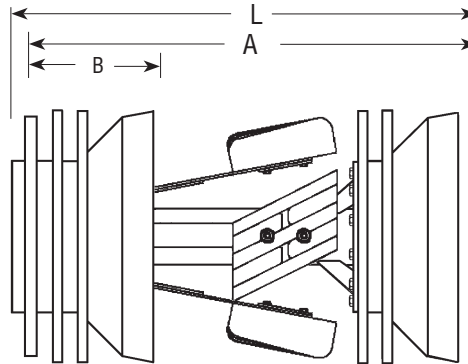

■ 5D2CC Blade Configuration

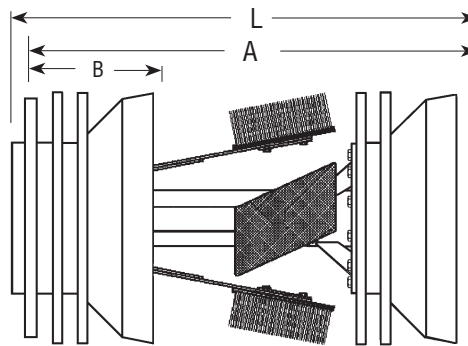

■ 5D2CC Brush Configuration

Size		5D2CC-BL Blade Cleaning Pig			5D2CC-BR Brush Cleaning Pig			5D2CC (Blade or Brush) Dimensions					
		Weight		Weight				A		B		L	
Inch	mm	Part Number	Lbs.	Kg.	Part Number	Lbs.	Kg.	Inch	mm	Inch	mm	Inch	mm
10	250	02-2955-0010	37	17	02-2956-0010	42	19	19-13/16	503	5-1/2	140	23-3/16	589
12	300	02-2955-0012	49	22	02-2956-0012	54	24	23-11/16	602	6-7/8	175	27-1/16	687
14	350	02-2955-0014	55	25	02-2956-0014	60	27	24-3/8	619	7-9/16	192	27-3/4	705
16	400	02-2955-0016	99	45	02-2956-0016	101	46	28-11/16	729	7-15/16	202	29-11/16	754
18	450	02-2955-0018	148	67	02-2956-0018	168	76	33-1/4	845	8-3/4	222	34-1/4	870
20	500	02-2955-0020	167	76	02-2956-0020	196	89	35-1/8	892	10-3/8	264	36-1/8	918
22	550	02-2955-0022	255	116	02-2956-0022	274	124	39-5/16	999	10-1/16	256	40-9/16	1030
24	600	02-2955-0024	296	134	02-2956-0024	323	147	41-5/16	1049	11-13/16	300	42-9/16	1081
26	650	02-2955-0026	339	154	02-2956-0026	370	168	45-13/16	1164	12-1/16	306	47-1/16	1195
28	700	02-2955-0028	413	187	02-2956-0028	456	207	48-5/16	1227	14-1/16	357	49-9/16	1259
30	750	02-2955-0030	517	234	02-2956-0030	544	247	53-3/8	1356	13-7/8	352	54-5/8	1387
32	800	02-2955-0032	578	262	02-2956-0032	616	279	55-1/4	1403	15-1/2	394	56-1/2	1435
34	850	02-2955-0034	728	330	02-2956-0034	766	347	62	1575	16	406	63-1/4	1607
36	900	02-2955-0036	833	378	02-2956-0036	898	407	64-1/8	1629	17-7/8	454	65-3/8	1661
40	1000	02-2955-0040	1147	520	02-2956-0040	1184	537	71-1/4	1818	18-3/4	476	72-1/2	1842
42	1050	02-2955-0042	1277	579	02-2956-0042	1332	604	73-1/4	1861	20-1/2	513	74-1/2	1892

Consult the factory for larger sizes.

VANTAGE® V Cleaning Pigs

DCDC Configurations

The DCDC VANTAGE® V Cleaning Pigs are recommended for medium to heavy cleaning. The 10- to 14-inch pigs will traverse 1.5 DR - 90° bends and 16-inches and larger will traverse 3.0 DR - 90° bends. This pig will traverse some long bowl check valves and full-opening wedge gate valves.

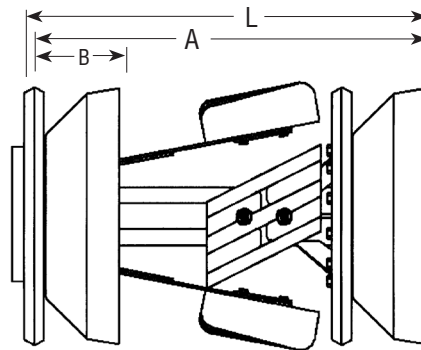

■ DCDC Blade Configuration

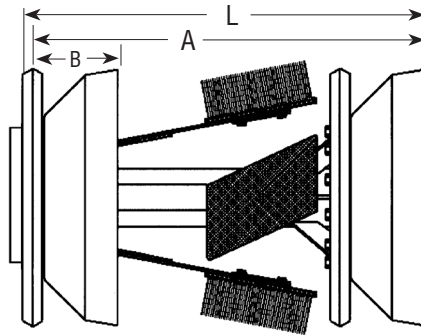

■ DCDC Brush Configuration

Size		DCDC-BL Blade Cleaning Pig			DCDC-BR Brush Cleaning Pig			DCDC C (Blade or Brush) Dimensions					
		Weight		Weight		Weight		A		B		L	
Inch	mm	Part Number	Lbs.	Kg.	Part Number	Lbs.	Kg.	Inch	mm	Inch	mm	Inch	mm
10	250	02-2865-0010	31	14	02-2864-0010	36	16	17-11/16	392	3-3/4	95	21-7/16	544
12	300	02-2865-0012	37	17	02-2864-0012	42	19	20-13/16	529	4-5/8	117	24-9/16	624
14	350	02-2865-0014	42	19	02-2864-0014	47	21	21-1/2	546	5-5/16	135	25-1/4	641
16	400	02-2865-0016	86	39	02-2864-0016	88	40	23-15/16	608	4-7/16	113	24-11/16	627
18	450	02-2865-0018	128	58	02-2864-0018	148	67	27-3/4	705	4-3/4	121	28-1/2	724
20	500	02-2865-0020	138	63	02-2864-0020	167	76	29	737	5-7/8	149	29-3/4	756
22	550	02-2865-0022	227	103	02-2864-0022	246	112	33-5/8	854	6	152	34-1/2	876
24	600	02-2865-0024	247	112	02-2864-0024	274	124	34-7/8	886	7-1/8	181	35-3/4	908
26	650	02-2865-0026	300	136	02-2864-0026	331	150	39-3/8	1000	7-3/8	187	40-1/4	1022
28	700	02-2865-0028	329	149	02-2864-0028	372	169	40-5/8	1032	8-3/8	213	41-1/2	1054
30	750	02-2865-0030	430	195	02-2864-0030	457	207	45-3/4	1162	8-5/8	219	46-3/4	1187
32	800	02-2865-0032	469	213	02-2864-0032	507	230	47	1194	9-5/8	244	48	1219
34	850	02-2865-0034	644	292	02-2864-0034	682	309	53-3/8	1356	9-3/4	248	54-5/8	1387
36	900	02-2865-0036	686	311	02-2864-0036	751	341	54-3/4	1391	11-1/8	283	56	1422
40	1000	02-2865-0040	982	445	02-2864-0040	1021	463	61-1/4	1556	11-1/2	292	62-3/4	1594
42	1050	02-2865-0042	1054	478	02-2864-0042	1109	503	62-1/2	1588	12-3/4	324	64	1626

Consult the factory for larger sizes.



VANTAGE® V Cleaning Pigs

VANTAGE® Pigs Will Traverse

Size		Maximum Gate Valve Seat Ring Spacing							
		2CC		DCDC		3D2CC		5D2CC	
Inch	mm	Inch	mm	Inch	mm	Inch	mm	Inch	mm
10	250	2-3/4	70	3-3/4	95	4-1/8	105	5	127
12	300	3-5/8	92	4-5/8	117	5-7/8	149	6-3/8	162
14	350	4-5/16	110	5-5/16	135	6-1/16	154	7-1/16	179
16	400	3-9/16	90	4-11/16	119	5-13/16	148	7-7/16	189
18	450	3-7/8	98	5	127	6-3/8	162	8-1/4	209
20	500	5-1/8	130	6-1/4	159	7-7/8	200	9-7/8	251
22	550	5	127	6-3/16	157	7-1/2	190	9-1/2	241
24	600	6-1/8	156	7-7/16	189	9-1/8	232	11-1/4	286
26	650	6-1/2	165	7-3/4	197	9-7/16	240	11-9/16	294
28	700	7-3/4	197	9	229	11-13/16	284	13-9/16	344
30	750	7-3/8	187	9	229	10-7/8	276	13-3/8	340
32	800	8-5/8	219	10-1/4	260	12-3/8	314	15	381
34	850	8-5/8	219	10-1/2	267	12-5/8	321	15-1/2	394
36	900	10	254	11-7/8	302	14-3/8	365	17-3/8	441
40	1000	10-1/4	260	12-1/2	318	14-7/8	378	18-1/4	464
42	1050	11-1/2	292	13-3/4	349	16-1/2	419	20	508

Consult the factory for parts or accessories not listed.

Size		Maximum Check Valve Bowl Length							
		2CC		DCDC		3D2CC		5D2CC	
Inch	mm	Inch	mm	Inch	mm	Inch	mm	Inch	mm
10	250	13-1/16	332	16-1/8	410	18-1/16	459	18-1/4	464
12	300	13-1/16	332	19-3/8	492	20-1/4	514	22-1/4	565
14	350	13-1/16	332	20-1/16	510	20-15/16	532	22-15/16	583
16	400	19-1/2	495	22-11/16	576	23-7/16	595	26-11/16	678
18	450	23-1/4	591	26-1/4	667	27-1/4	692	31	787
20	500	23-1/2	597	27-1/4	692	28-5/8	727	32-5/8	829
22	550	28-1/4	718	31-3/4	806	32-1/2	826	36-1/2	927
24	600	28-1/2	724	32-3/4	832	34	864	38-1/4	972
26	650	33	838	37	940	38-5/16	973	42-9/16	1081
28	700	33-1/4	845	38	965	40-1/16	1018	44-13/16	1138
30	750	38-3/4	984	43	1092	44-5/8	1133	49-5/8	1260
32	800	39	991	44	1118	46	1168	51-1/4	1302
34	850	45-1/4	1149	50-3/8	1280	52	1321	57-3/4	1467
36	900	45-1/2	1156	51-1/2	1308	53-5/8	1362	59-5/8	1514
40	1000	51-3/4	1314	57-3/4	1467	59-1/2	1511	66-1/4	1683
42	1050	52	1321	58-3/4	1492	61	1549	68	1727

Consult the factory for parts or accessories not listed.



VANTAGE® V Cleaning Pigs

Replacement Cups/Discs

Size		Standard VANTAGE®	RealSeal®			
Inch	mm	Conical Cups	Conical Cups	Disc for DCDC Pigs	Scraper Seal Disc	Guide/Support Disc
10	250	00-4120-0010-03	00-7457-0010	00-1702-0003	00-7698-0010	00-7699-0010
12	300	00-4120-0012-03	00-7457-0012	00-1702-0004	00-7698-0012	00-7699-0012
14	350	00-4120-0014-03	00-7457-0014	00-1702-0010	00-7698-0014	00-7699-0014
16	400	00-4120-0016	00-7457-0016	00-6414-0016	00-7698-0016	00-7699-0016
18	450	00-4120-0018	00-7457-0018	00-6414-0018	00-7698-0018	00-7699-0018
20	500	00-4120-0020	00-7457-0020	00-6414-0020	00-7698-0020	00-7699-0020
22	550	00-4120-0022	00-7457-0022	00-6414-0022	00-7698-0022	00-7699-0022
24	600	00-4120-0024	00-7457-0024	00-6414-0024	00-7698-0024	00-7699-0024
26	650	00-4120-0026	00-7457-0026	00-6414-0026	00-7698-0026	00-7699-0026
28	700	00-4120-0028	00-7457-0028	00-6414-0028	00-7698-0028	00-7699-0028
30	750	00-4120-0030	00-7457-0030	00-6414-0030	00-7698-0030	00-7699-0030
32	800	00-4120-0032	00-7457-0032	00-6414-0032	00-7698-0032	00-7699-0032
34	850	00-4120-0034	00-7457-0034	00-6414-0034	00-7698-0034	00-7699-0034
36	900	00-4120-0036	00-7457-0036	00-6414-0036	00-7698-0036	00-7699-0036
40	1000	00-4120-0040	00-7457-0040	00-6414-0040	00-7698-0040	00-7699-0040
42	1050	00-4120-0042	00-7457-0042	00-6414-0042	00-7698-0042	00-7699-0042

Replacement Blades and Brushes

Size		Blade			Brush			Brush Holder		
Inch	mm	Lbs.	Kg.	Part Number	Lbs.	Kg.	Part Number	Lbs.	Kg.	Part Number
10	250	.75	.34	00-1716-0018	1.5	.68	00-0359-0001	.25	.11	00-0349-0001
12	300	.75	.34	00-1716-0018	1.5	.68	00-0359-0001	.25	.11	00-0349-0001
14	350	.75	.34	00-1716-0018	1.5	.68	00-0359-0001	.25	.11	00-0349-0001
16	400	1-1/4	0.6	00-1716-0010	2	0.9	00-4127-0001	0.4	0.02	00-4143-0001
18-24	450-600	4-1/2	2	00-1716-0011	4	1.8	00-4127-0003	0.8	0.04	00-4143-0002
26-42	650-1050	5-1/4	2.4	00-1716-0013	4	1.8	00-4127-0003	0.8	0.04	00-4143-0002

Consult the factory for parts or accessories not listed.



T.D. Williamson

3000.004.06 - p8



VANTAGE® V Batching Pigs

VANTAGE® Pigs Will Traverse

Size		Maximum Gate Valve Seat Ring Spacing									
		2CC		4CC		DCDC		3D2CC		5D2CC	
Inch	mm	Inch	mm	Inch	mm	Inch	mm	Inch	mm	Inch	mm
10	250	2-3/4	70	5-3/16	132	3-3/4	95	4-1/8	105	5	127
12	300	3-5/8	92	6-11/16	170	4-5/8	117	5-7/8	149	6-3/8	162
14	350	4-5/16	110	7-3/8	187	5-5/16	135	6-1/16	154	7-1/16	179
16	400	3-9/16	90	6-13/16	173	4-11/16	119	5-13/16	148	7-7/16	189
18	450	3-7/8	98	7-5/8	194	5	127	6-3/8	162	8-1/4	209
20	500	5-1/8	130	8-5/8	225	6-1/4	159	7-7/8	200	9-7/8	251
22	550	5	127	9-1/2	241	6-3/16	157	7-1/2	190	9-1/2	241
24	600	6-1/8	156	10-3/4	273	7-7/16	189	9-1/8	232	11-1/4	286
26	650	6-1/2	165	11-9/16	294	7-3/4	197	9-7/16	240	11-9/16	294
28	700	7-3/4	197	12-13/16	325	9	229	11-13/16	284	13-9/16	344
30	750	7-3/8	187	13-1/8	333	9	229	10-7/8	276	13-3/8	340
32	800	8-5/8	219	14-3/8	365	10-1/4	260	12-3/8	314	15	381
34	850	8-5/8	219	15-1/8	384	10-1/2	267	12-5/8	321	15-1/2	394
36	900	10	254	16-1/2	419	11-7/8	302	14-3/8	365	17-3/8	441
40	1000	10-1/4	260	17-3/4	451	12-1/2	318	14-7/8	378	18-1/4	464
42	1050	11-1/2	292	19	483	13-3/4	349	16-1/2	419	20	508

Consult the factory for parts or accessories not listed.

Size		Maximum Check Valve Bowl Length									
		2CC		4CC		DCDC		3D2CC		5D2CC	
Inch	mm	Inch	mm	Inch	mm	Inch	mm	Inch	mm	Inch	mm
10	250	13-1/16	332	15-1/8	384	16-1/8	410	13-1/2	343	15-1/4	387
12	300	13-1/16	332	19-1/8	486	19-3/8	492	18	457	20	508
14	350	13-1/16	332	19-1/8	486	20-1/16	510	18-11/16	475	20-11/16	525
16	400	19-1/2	495	21-3/4	552	22-11/16	576	23-7/16	595	26-11/16	678
18	450	23-1/4	591	25-3/4	654	26-1/4	667	27-1/4	692	31	787
20	500	23-1/2	597	25-3/4	654	27-1/4	692	28-5/8	727	32-5/8	829
22	550	28-1/4	718	31-1/8	791	31-3/4	806	32-1/2	826	36-1/2	927
24	600	28-1/2	724	31-1/8	791	32-3/4	832	34	864	38-1/4	972
26	650	33	838	35-7/8	911	37	940	38-5/16	973	42-9/16	1081
28	700	33-1/4	845	35-7/8	911	38	965	40-1/16	1018	44-13/16	1138
30	750	38-3/4	984	41-3/4	1060	43	1092	44-5/8	1133	49-5/8	1260
32	800	39	991	41-3/4	1060	44	1118	46	1168	51-1/4	1302
34	850	45-1/4	1149	48-1/2	1232	50-3/8	1280	52	1321	57-3/4	1467
36	900	45-1/2	1156	48-1/2	1232	51-1/2	1308	53-5/8	1362	59-5/8	1514
40	1000	51-3/4	1314	55-1/4	1403	57-3/4	1467	59-1/2	1511	66-1/4	1683
42	1050	52	1321	55-1/4	1403	58-3/4	1492	61	1549	68	1727

Consult the factory for parts or accessories not listed.



VANTAGE® V Batching Pigs

Replacement Cups/Discs

Inch	Size mm	Standard VANTAGE®	RealSeal®	Discs for DCDC pigs	Scraper Seal Disc	Guide/Support Disc
		Conical Cups	Conical Cups			
10	250	00-4120-0010-03	00-7457-0010	00-1702-0003	00-7698-0010	00-7699-0010
12	300	00-4120-0012-03	00-7457-0012	00-1702-0004	00-7698-0012	00-7699-0012
14	350	00-4120-0014-03	00-7457-0014	00-1702-0010	00-7698-0014	00-7699-0014
16	400	00-4120-0016	00-7457-0016	00-6414-0016	00-7698-0016	00-7699-0016
18	450	00-4120-0018	00-7457-0018	00-6414-0018	00-7698-0018	00-7699-0018
20	500	00-4120-0020	00-7457-0020	00-6414-0020	00-7698-0020	00-7699-0020
22	550	00-4120-0022	00-7457-0022	00-6414-0022	00-7698-0022	00-7699-0022
24	600	00-4120-0024	00-7457-0024	00-6414-0024	00-7698-0024	00-7699-0024
26	650	00-4120-0026	00-7457-0026	00-6414-0026	00-7698-0026	00-7699-0026
28	700	00-4120-0028	00-7457-0028	00-6414-0028	00-7698-0028	00-7699-0028
30	750	00-4120-0030	00-7457-0030	00-6414-0030	00-7698-0030	00-7699-0030
32	800	00-4120-0032	00-7457-0032	00-6414-0032	00-7698-0032	00-7699-0032
34	850	00-4120-0034	00-7457-0034	00-6414-0034	00-7698-0034	00-7699-0034
36	900	00-4120-0036	00-7457-0036	00-6414-0036	00-7698-0036	00-7699-0036
40	1000	00-4120-0040	00-7457-0040	00-6414-0040	00-7698-0040	00-7699-0040
42	1050	00-4120-0042	00-7457-0042	00-6414-0042	00-7698-0042	00-7699-0042