



# STOPPLE® Plugging Machine

## Sizes: 4-inches and Larger



T.D. Williamson, Inc.

Bulletin No: 1030.001.02

Date: October 2010

Cross Indexing No: n/a

Supersedes: 1030.001.01 (2/05)



■ STOPPLE® Plugging Machine

### Description

TDW STOPPLE® Plugging Machines serve as temporary block valves installed anywhere in a piping system. They are used to isolate a section of line for repairs or additions without interruption of service.

The STOPPLE Plugging Machine consists of three major sections: a hydraulic cylinder or jackscrew, a plugging head housing, and a plugging head.

### Features

Operation of the hydraulic STOPPLE Plugging Machine is easy due to the location of the control valve, which is positioned at the lower end of the hydraulic cylinder. The hydraulically operated control bar has a direct reading scale visible to the operator, enabling him to know the plugging head position at all times.

- The TDW STOPPLE Plugging Machine is available for pipe sizes 4" (DN 100) and larger.

Its maximum operating temperature is 180°F (82°C).

\* For design code options not listed and additional sizes, consult your sales representative.

### Typical Setup

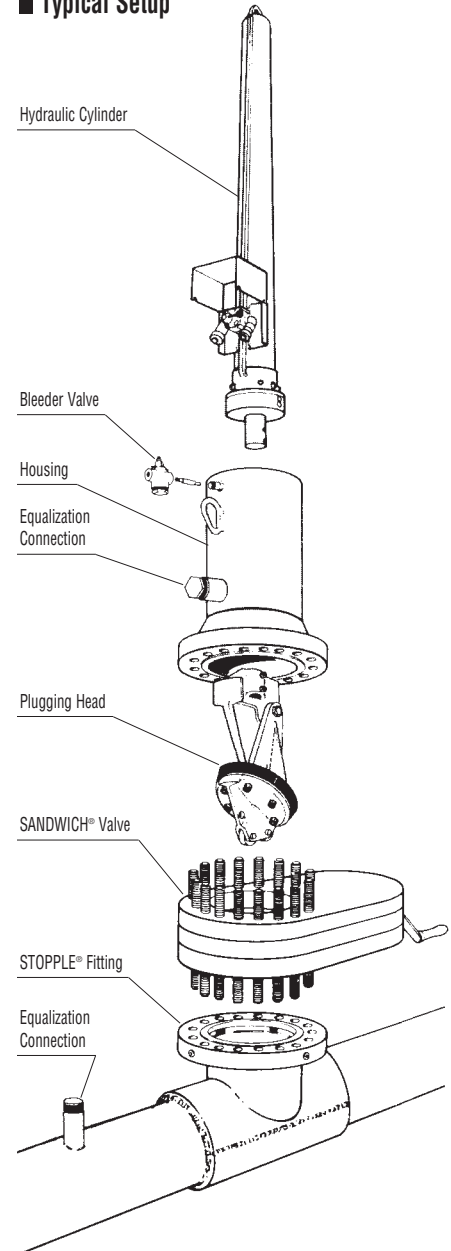

ISO 9001 Certified

Toll Free

**1-888-TDWmSon (839-6766)**



# STOPPLE® Plugging Machine

## Cylinder Operation

Jackscrew Operated Cylinder	Lbs.	Kg.	Part Number
4" (DN 100) and 6" (DN 150)	69	31	08-0299-0000
Hydraulic Operated Cylinders			
6" (DN 150), 8" (DN 200), 10" (DN 250), 12" (DN 300)	235	107	08-2116-0000
14" (DN 350), 16" (DN 400), 18" (DN 450), 20" (DN 500)	862	391	08-2117-0000
22" (DN 550), 24" (DN 600), 26" (DN 650), 30" (DN 750), 36" (DN 900)	1800	816	08-2118-0000

### ■ Fall Protection Assembly



## Safety Harness Assembly

Cylinder	Fall Protection Assembly
08-2116-0000	08-2546-0000
08-2117-0000	08-2547-0000
08-2118-0000	08-2548-0000
08-2119-0000	08-2549-0000

## Plugging Heads & Sealing Elements

Size		Plugging Heads			Sealing Elements		
Inches	DN	Lbs.	Kg.	Part Number	Lbs.	Kg.	Part Number
4	100	7	3	08-2578-0000*	1	.5	08-0036-0005
6	150	25	11	08-2579-0000*	2	.9	08-0040-0005
8	200	50	23	08-2580-0000*	2	.9	08-0246-0005
10	250	90	41	08-2581-0000*	4	2	08-0247-0005
12	300	150	68	08-2582-0000*	5	2	08-0248-0005
14	350	185	84	08-1892-0000	7	3	08-0249-0005
16	400	260	118	08-1893-0000	9	4	08-0250-0005
18	450	455	206	08-1894-0000	12	5	08-0251-0005
20	500	525	238	08-1895-0000	19	9	08-0252-0005
22	550	670	304	08-1896-0000	24	11	08-0253-0005
24	600	870	395	08-1897-0000	37	17	08-0254-0005
26	650	1050	476	08-1898-0000	40	18	08-1863-0005
30	750	1610	730	08-1900-0000	64	29	08-1623-0005
36	900	3025	1372	08-2048-0000	77	35	08-2046-0005

\*This plugging head is furnished with 2 nose pieces

When ordering sealing elements specify pipe ID, pressure, material of sealing element desired and number of bolt holes and bolt circle diameter required. Factory recommends two elements be purchased with each plugging head, one to be used as a spare. STD Machines are designed for STD weight pipe. If used in heavy or thin wall pipe, special components may be required.

## STOPPLE® Housings

Housings For Jackscrew Cylinders:				Class 150			Class 300			Class 600		
Inches	DN	Lbs.	Kg.	Part Number	Lbs.	Kg.	Part Number	Lbs.	Kg.	Part Number		
4	100	32	15	08-0319-0000	43	20	08-0320-0000	60	27	08-0300-0000		
6	150	56	25	08-0322-0000	73	33	08-0323-0000	75	34	08-0302-0000		
Housings For Hydraulic Cylinders:				Class 150			Class 300			Class 600		
6	150	56	25	08-0270-0000	73	33	08-0276-0000	75	34	08-1715-0000		
8	200	92	42	08-0202-0000	130	59	08-0213-0000	187	85	08-1716-0000		
10	250	128	58	08-0203-0000	185	84	08-0214-0000	270	122	08-1645-0000		
12	300	200	91	08-0204-0000	285	129	08-0215-0000	350	159	08-1646-0000		
14	350	327	148	08-0205-0000	410	186	08-0216-0000	570	259	08-1647-0000		
16	400	410	186	08-0206-0000	535	243	08-0217-0000	660	299	08-2170-0000		
18	450	480	218	08-0207-0000	655	297	08-0218-0000	955	433	08-2169-0000		
20	500	600	272	08-0208-0000	735	333	08-0219-0000	1025	465	08-1648-0000		
22	550	770	349	08-0209-0000	985	447	08-0220-0000	1365	619	08-1664-0000		
24	600	935	424	08-0210-0000	1225	556	08-0221-0000	1740	789	08-1649-0000		
26	650	1075	488	08-0211-0000	1410	640	08-0222-0000	1875	851	08-1864-0000		
30	750	1425	646	08-0212-0000	1795	814	08-0223-0000	2440	1107	08-1650-0000		
36	900	1550	703	08-0423-0000	2100	953	08-0360-0000	5130	2327	08-2257-0000		

Note: Housings are equipped with flanges which are drilled, faced and pressure-rated to match ANSI Class 150, 300 or 600 flanges.



# STOPPLE® Plugging Machine

## Approximate Dimensions for Determining Machine Clearances

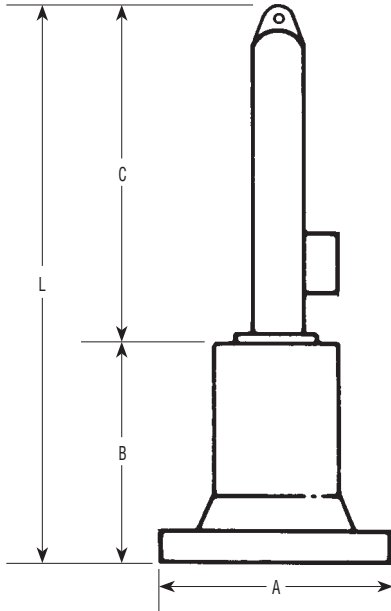

Size		A*		B*		C		L	
Inches	DN	Inches	mm	Inches	mm	Inches	mm	Inches	mm
4	100	11	280	14	356	58	1473	72	1829
6	150	14	356	17	432	58	1473	75	1905
8	200	17	432	19	483	85	2159	104	2642
10	250	20	508	23	533	85	2159	108	2743
12	300	22	559	25	610	85	2159	110	2794
14	350	24	610	32	787	124	3150	156	3962
16	400	27	686	35	889	124	3150	159	4039
18	450	30	762	39	991	124	3150	163	4140
20	500	32	813	42	1041	124	3150	166	4216
22	550	35	889	46	1168	166	4216	212	5385
24	600	37	940	52	1321	166	4216	218	5537
26	650	40	1015	52	1321	166	4216	218	5537
30	750	45	1143	60	1524	166	4216	226	5740
36	900	52	1321	67	1803	166	4216	233	5918

\*Maximum with 600 Class Flange.

The TDW 660/760 Tapping Machine power unit normally operates 6" (DN 150) through 12" (DN 300) plugging machines. The power unit for the 1200 Tapping Machines operates 14" (DN 350) and larger.

Hydraulic cylinder (08-2116-0000) is furnished with hydraulic couplings for 660/760 Tapping Machine power unit.

Hydraulic cylinders (08-2117-0000, 08-2118-0000, and 08-2119-0000) are furnished with hydraulic couplings for 1200 Tapping Machine power units.

Hydraulic cylinder (08-2117-0000) can be used with the 660/760 power unit with the purchase of a conversion kit (08-0384-0000).

If other power unit to hydraulic cylinder combinations are to be used, be sure to specify so that proper couplings can be furnished.

## Plugging Head Specifications

	Control Bar Travel		Max. Operating Pressure	
	Inches	mm	psi	bar
with Jackscrew Cylinder				
4" (DN 100) and 6" (DN 150)	48	1219	900	62
with Hydraulic Cylinders				
*6" (DN 150), 8" (DN 200), 10" (DN 250), 12" (DN 300)	72	1829	900	62
14" (DN 350), 16" (DN 400), 18" (DN 450), 20" (DN 500)	102	2604	750	52
22" (DN 550), 24" (DN 600), 26" (DN 650), 30" (DN 750)	140	3556	625	43
36" (DN 900)	140	3556	1000	70

NOTE: This chart is applicable to STOPPLE® equipment ordered from and manufactured at the Tulsa Manufacturing Plant. STOPPLE equipment ordered from and manufactured at TDW (SA) in Belgium is designed for a standard maximum operating pressure of 1,000 psi (70 bar). For STOPPLE equipment requiring higher pressure ratings or sizes other than those indicated in the above chart, consult the factory.

\*When ordering 6" (DN 150) STOPPLE equipment, please specify either jackscrew or hydraulic cylinder.



# Plugging Without Shutdown - Typical Procedure

## 1. Weld Fittings

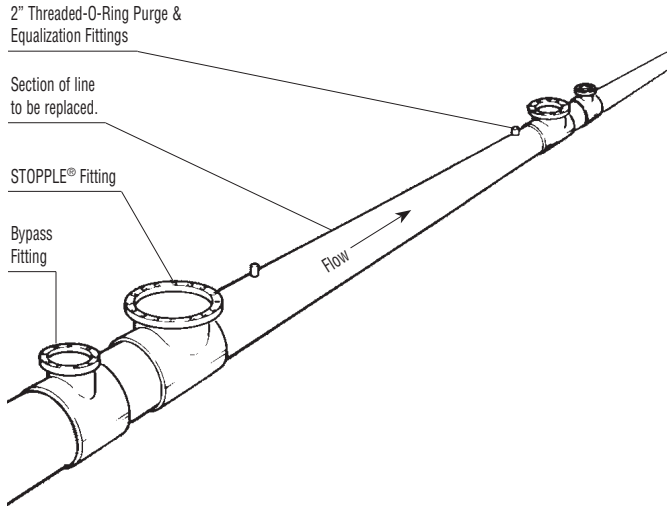

STOPPLE® Fittings with LOCK-O-RING® Flanges\* are welded on each end of the section to be isolated. Bypass fittings with LOCK-O-RING Flanges and equalization fittings are welded to the line.

\*See LOCK-O-RING Flanges, Bulletin 1120.001.

## 2. Make Taps

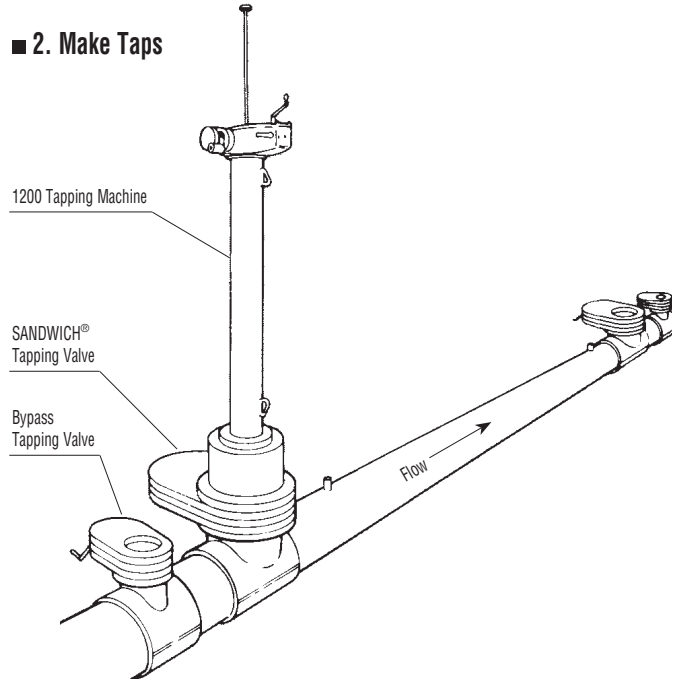

A Tapping Valve\* is mounted on each fitting and taps are made through the valves into the pipeline. The cutter is withdrawn after each tap, the valve closed, and tapping machine removed.

\*See SANDWICH® Valve, Bulletin 1020.001.

## 3. Plug Line

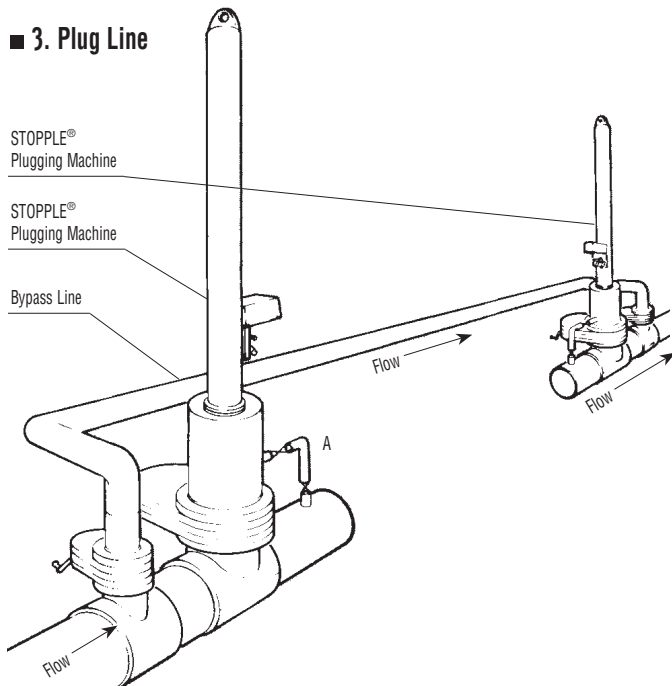

Bypass connections are made and the bypass valves are opened. STOPPLE Plugging Machines are mounted and the plugging heads are lowered through valves into sealing position. After the new section is tied in, pressure is equalized by connection from the STOPPLE Housing to the pipeline (See A).

## 4. Recover Valves

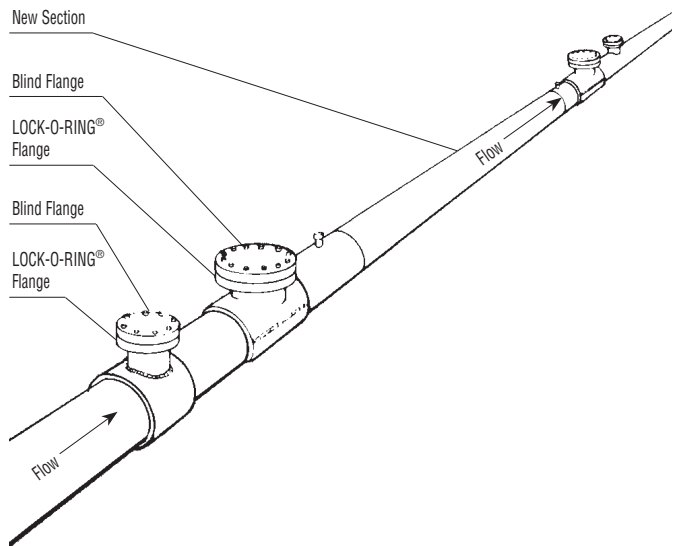

Tapping machine cutters are replaced with LOCK-O-RING Plugs, and tapping machines (or machine) are mounted on valves. The LOCK-O-RING Plugs are lowered into position inside LOCK-O-RING Flanges. Tapping machines are removed, valves recovered, and blind flanges installed.