



TracMaster™

Magnetic Pig Tracking & Locating System



T.D. Williamson, Inc.

Bulletin No: 5000.003.01

Date: June 2005

Cross Indexing No: n/a

Supersedes: 5000.003.00 (9/00)



■ TracMaster™ Pig Tracker and Locator

Description

Designed exclusively for the pigging industry, the TDW TracMaster™ Pig Tracker and Locator provides a visual display as well as an audible signal of stopped or moving pigs in a pipeline. The need to “walk and stop” is eliminated with TracMaster because extraneous signals and noise are filtered out as it accurately detects, reports and stores pig passages, locations, times and dates. Pigging activities are reported via a simple, graphic menu system and display that reveal the distinctive pulsing pattern of a passing pig plus quick, precise locations of stationary pigs. This information is provided for on-site viewing and printed reports, and is transferrable to desktop PCs.

Features

T. D. Williamson, Inc., is committed to providing you with the exact product to assist you in meeting the needs of your individual applications.

- Simple, graphic menu system and a display reveal the distinctive pulsing pattern of a passing pig as well as stationary pigs.
- As pig passages are detected, their count, location, time and date are stored in the TracMaster’s memory.
- Pig activity can be recalled for on-site viewing and report printing, and can be transferred to a desktop PC.
- The pig passage recording list on the display can be used to obtain the average pig speed, as well as elapsed time and distance, between any two recordings.
- A list of pig passages shows the time, date, and image, and optionally, the mile or foot marker of each recording location on the pipeline.

- A built-in help menu provides assistance with many functions.
- The receiver’s graphic screen is backlit for readability in dim light; the screen blanks to save energy and automatically reactivates when passing pigs are detected.
- Built-in speakers indicate pig passages, transmitter pulses, button presses, etc.
- All information can be printed out on standard dot matrix printers.
- Transmitters fit inside or can be towed behind all types of foam, unicast and metal pigs.
- Receiving antennas reject false signals created during movement, allowing operators to walk continuously without interference and eliminating the time-consuming “walk and stop” method of other tracking systems.
- The receiver’s stainless steel chassis is designed to endure rough pipeline conditions, is water resistant, and has both serial and printer ports. Battery life is rated at 40 hours with all options on, including the backlight.
- System software can be upgraded to new versions as they become available.

Options

- The TracMaster Pig Tracking and Locating System is available for purchase or rental.

USA: 1-800-571-7447
England: (44) 1-793-603600



TracMaster™ Pig Tracker & Locator

The TracMaster™ Pig Tracking & Locating System is available in six different packaged models.



Pig Tracking & Locating System for 6" - 28" Pipelines (Model TDW/CD42-K1)

| Description | Quantity | Part Number | Weight | |
|---------------------------------------|----------|---------------------|-----------|-----------|
| | | | Lbs. | Kgs. |
| Tracking & Locating System | 1 | 00-7496-0023 | 50 | 35 |
| System includes: | | | | |
| Receiver | 1 | 00-7496-0007 | 10 | 4.5 |
| General Purpose Antenna | 1 | 00-7496-0008 | 10 | 4.5 |
| Transmitter (T-1) | 1 | 00-7496-0006 | 6.0 | 2.7 |
| Antenna Cable | 1 | 00-7496-0011 | 1.0 | 0.5 |
| Shoulder Strap for Receiver | 1 | 00-7496-0014 | | |
| Shoulder Strap for Antenna | 1 | 00-7496-0015 | | |
| Carrying/Shipment Case | 1 | 00-7496-0016 | 30 | 14 |
| D-Cell Replacement Batteries | 5 | 00-7496-0017 | | |
| AA-Cell Replacement Batteries | 6 | | | |

Pig Tracking & Locating System for 6" - 28" Pipelines with Dual-Receiver Equipment (Model TDW/CD42-K2)

| Description | Quantity | Part Number | Weight | |
|---------------------------------------|----------|---------------------|-----------|-----------|
| | | | Lbs. | Kgs. |
| Tracking & Locating System | 1 | 00-7496-0038 | 67 | 30 |
| System includes: | | | | |
| Receivers | 2 | 00-7496-0007 | 10 | 4.5 |
| General Purpose Antennas | 2 | 00-7496-0008 | 10 | 4.5 |
| Transmitter (T-1) | 1 | 00-7496-0006 | 6.0 | 2.7 |
| Antenna Cables | 2 | 00-7496-0011 | 1.0 | 0.5 |
| Shoulder Straps for Receivers | 2 | 00-7496-0014 | | |
| Shoulder Straps for Antennas | 2 | 00-7496-0015 | | |
| Carrying/Shipment Cases | 2 | 00-7496-0016 | 30 | 14 |
| D-Cell Replacement Batteries | 10 | 00-7496-0017 | | |
| AA-Cell Replacement Batteries | 6 | 00-7496-0022 | | |



Pig Tracking & Locating System for 30" - 60" Pipelines (Model TDW/CD42-K3)

| Description | Quantity | Part Number | Weight | |
|---------------------------------------|----------|---------------------|-----------|-----------|
| | | | Lbs. | Kgs. |
| Tracking & Locating System | 1 | 00-7496-0003 | 63 | 29 |
| System includes: | | | | |
| Receiver | 1 | 00-7496-0007 | 10 | 4.5 |
| General Purpose Antenna | 1 | 00-7496-0008 | 10 | 4.5 |
| Transmitter (T-2) | 1 | 00-7496-0005 | 17 | 7.7 |
| Antenna Cable | 1 | 00-7496-0011 | 1.0 | 0.5 |
| Shoulder Strap for Receiver | 1 | 00-7496-0014 | | |
| Shoulder Strap for Antenna | 1 | 00-7496-0015 | | |
| Carrying/Shipment Case | 1 | 00-7496-0016 | 30 | 14 |
| D-Cell Replacement Batteries | 5 | 00-7496-0017 | | |
| C-Cell Replacement Batteries | 6 | 00-7496-0018 | | |



TracMaster™ Pig Tracker & Locator

The TracMaster™ Pig Tracking & Locating System is available in six different packaged models.



Pig Tracking & Locating System for 30" - 60" Pipelines with Dual-Receiver Equipment (Model TDW/CD42-K4)

| Description | Quantity | Part Number | Weight | |
|---------------------------------------|----------|---------------------|-----------|-----------|
| | | | Lbs. | Kgs. |
| Tracking & Locating System | 1 | 00-7496-0004 | 78 | 35 |
| System includes: | | | | |
| Receivers | 2 | 00-7496-0007 | 10 | 4.5 |
| General Purpose Antennas | 2 | 00-7496-0008 | 10 | 4.5 |
| Transmitter (T-2) | 1 | 00-7496-0005 | 17 | 7.7 |
| Antenna Cables | 2 | 00-7496-0011 | 1.0 | 0.5 |
| Shoulder Straps for Receivers | 2 | 00-7496-0014 | | |
| Shoulder Straps for Antennas | 2 | 00-7496-0015 | | |
| Carrying/Shipment Cases | 2 | 00-7496-0016 | 30 | 14 |
| D-Cell Replacement Batteries | 10 | 00-7496-0017 | | |
| C-Cell Replacement Batteries | 6 | 00-7496-0018 | | |



Pig Tracking & Locating System for 4" - 8" Pipelines (Model TDW/CD42-K7)

| Description | Quantity | Part Number | Weight | |
|---------------------------------------|----------|---------------------|-----------|-----------|
| | | | Lbs. | Kgs. |
| Tracking & Locating System | 1 | 00-7496-0033 | 45 | 20 |
| System includes: | | | | |
| Receiver | 1 | 00-7496-0007 | 10 | 4.5 |
| General Purpose Antenna | 1 | 00-7496-0008 | 10 | 4.5 |
| Transmitter (T-0) | 1 | 00-7496-0019 | 3.0 | 1.4 |
| Antenna Cable | 1 | 00-7496-0011 | 1.0 | 0.5 |
| Shoulder Strap for Receiver | 1 | 00-7496-0014 | | |
| Shoulder Strap for Antenna | 1 | 00-7496-0015 | | |
| Carrying/Shipment Case | 1 | 00-7496-0016 | 30 | 14 |
| D-Cell Replacement Batteries | 5 | 00-7496-0017 | | |
| N-Cell Replacement Batteries | 6 | 00-7496-0042 | | |

Pig Tracking & Locating System for 4" - 8" Pipelines with Dual-Receiver Equipment (Model TDW/CD42-K8)

| Description | Quantity | Part Number | Weight | |
|---------------------------------------|----------|---------------------|-----------|-----------|
| | | | Lbs. | Kgs. |
| Tracking & Locating System | 1 | 00-7496-0034 | 62 | 28 |
| System includes: | | | | |
| Receivers | 2 | 00-7496-0007 | 10 | 4.5 |
| General Purpose Antennas | 2 | 00-7496-0008 | 10 | 4.5 |
| Transmitter (T-0) | 1 | 00-7496-0019 | 3.0 | 1.4 |
| Antenna Cables | 2 | 00-7496-0011 | 1.0 | 0.5 |
| Shoulder Straps for Receivers | 2 | 00-7496-0014 | | |
| Shoulder Straps for Antennas | 2 | 00-7496-0015 | | |
| Carrying/Shipment Cases | 2 | 00-7496-0016 | 30 | 14 |
| D-Cell Replacement Batteries | 10 | 00-7496-0017 | | |
| N-Cell Replacement Batteries | 6 | 00-7496-0042 | | |





TracMaster™ Components

■ T-0 Transmitter

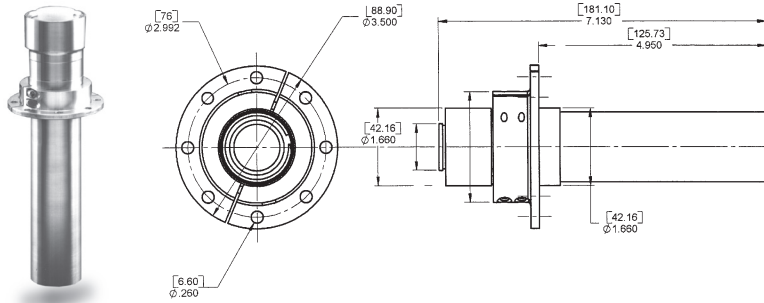

| Description | Quantity | Part Number | Weight | |
|----------------------|----------|--------------|--------|------|
| | | | Lbs. | Kgs. |
| CD42-T-0 Transmitter | 1 | 00-7496-0019 | 3.0 | 1.4 |

■ T-1 Transmitter

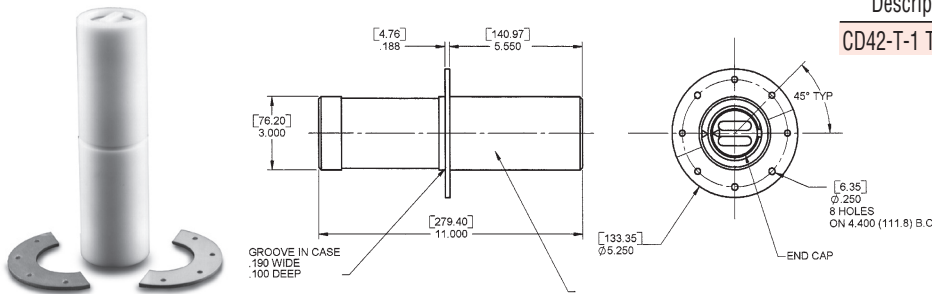

| Description | Quantity | Part Number | Weight | |
|----------------------|----------|--------------|--------|------|
| | | | Lbs. | Kgs. |
| CD42-T-1 Transmitter | 1 | 00-7496-0006 | 6.0 | 2.7 |

■ T-2 Transmitter

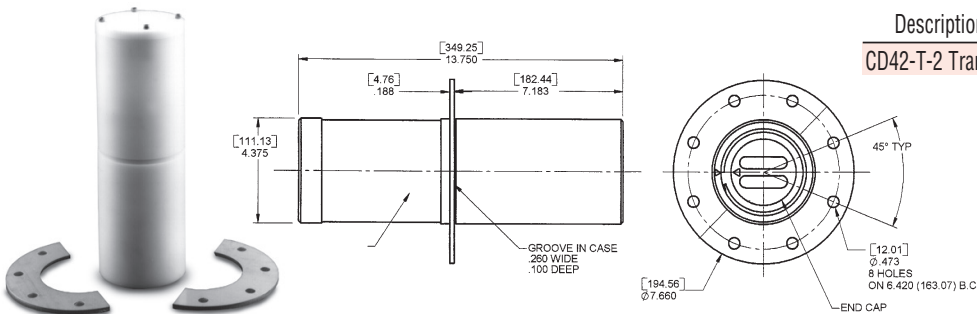

| Description | Quantity | Part Number | Weight | |
|----------------------|----------|--------------|--------|------|
| | | | Lbs. | Kgs. |
| CD42-T-2 Transmitter | 1 | 00-7496-0005 | 17 | 7.7 |

■ Receiver



| Description | Quantity | Part Number | Weight | |
|-----------------|----------|--------------|--------|------|
| | | | Lbs. | Kgs. |
| CD42-R Receiver | 1 | 00-7496-0007 | 10 | 4.5 |

■ Antenna



| Description | Quantity | Part Number | Weight | |
|-----------------|----------|--------------|--------|------|
| | | | Lbs. | Kgs. |
| CD42-GP Antenna | 1 | 00-7496-0008 | 10 | 4.5 |