



# PIG-SIG® IV

## Scraper Passage Indicator



T.D. Williamson, Inc.

Bulletin No: 5110.001.03

Date: June 2008

Cross Indexing No: n/a

Supersedes: 5110.001.02 (1/06)

■ Flag Indicator



■ Electrical Indicator

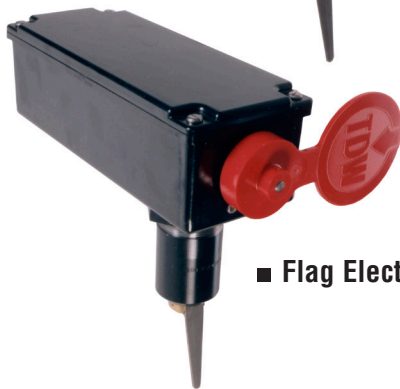

■ Flag Electrical Indicator

### Description

TDW's PIG-SIG® IV Scraper Passage Indicator is a device installed on a pipeline to detect the passage of a pig or sphere. The most common indicators have a trigger extending into the pipeline through a welded fitting that has been tapped. When a pig passes, the trigger is tripped, activating the signaling mechanism.

Signaling systems available include a flag indicator, electrical indicator or flag/electrical indicator. All indicators are compatible with all standard plug assemblies now in the field and are interchangeable. This makes it possible to use these units as conversion kits as well as complete PIG-SIG Indicators.

### Features

The PIG-SIG IV is weatherproof and corrosion-resistant. It features housings manufactured from space age plastic for durability and weather resistance. The flag indicator offers high visibility from the air or the ground. The electrical indicator switch has UL, CSA and European approvals. The carbon steel nipple is manufactured from easily weldable material. The PIG-SIG Indicator can be installed on or removed from a pressured pipeline using a TDW T-101 Tapping Machine and accessories.

### Options

T. D. Williamson, Inc. is committed to providing you with the exact product to assist you in planning, budgeting and meeting the specifications for your individual application needs.

The PIG-SIG IV Scraper Passage Indicator is available in a number of different materials, depending on product carried in the pipeline.

The following options are available:

- Flag Indicator with Manual Reset;
  - Rotary Cap Indicator with Manual Reset;
  - Electrical Indicator with Auto Reset;
  - Flag/Electrical Indicator combined.
- 
- Extended models are available in all configurations.
  - Unidirectional or bidirectional models are available.
  - Special materials and O-Ring seals are available.
  - Models are available for environmentally harsh conditions.
  - Nipple can be furnished with flanged or threaded mounting.
  - Stainless steel or brass trigger assemblies are available.
  - "Build your own" PIG-SIG IV Assembly from the following charts.

**USA: 1-800-571-7447**  
**England: (44) 1-793-603600**

# PIG-SIG® IV Scrapper Passage Indicators

04-7778 -

## Indicator Assembly

Indicator Option	Part Number
0 = Flag with Manual Reset	04-3150-0000
1 = Electrical with Auto Reset	04-3151-0000
2 = Flag/Electrical combined	04-3152-0000

## Shaft Assembly

Shaft Option	Part Number
0 = Nonextended	04-3149-0000
1 = 12" Extension	04-3168-0012
2 = 24" Extension	04-3168-0024
3 = 36" Extension	04-3168-0036
4 = 48" Extension	04-3168-0048
5 = 60" Extension	04-3168-0060
6 = 72" Extension	04-3168-0072
7 = 84" Extension	04-3168-0084
8 = 96" Extension	04-3168-0096
9 = 108" Extension	04-3168-0108

## Plug Assembly

Plug Assembly Option	Part Number
0 = Unidirectional, Brass	04-3051-000X
5 = Bidirectional, Brass	04-3753-000X
2 = Unidirectional, 316 SST	04-3052-000X
7 = Bidirectional, 316 SST	04-3754-000X

Note: The last digit of the plug assembly corresponds to O-ring material option.

Flag

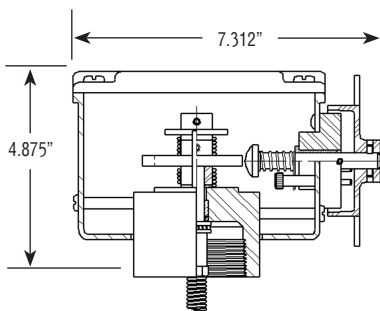

Electrical

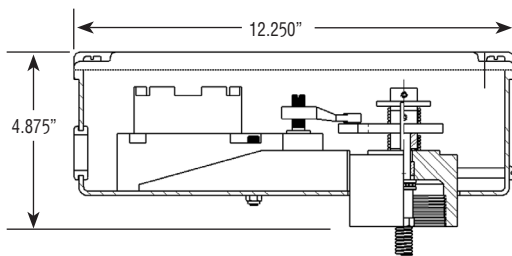

Flag/Electrical

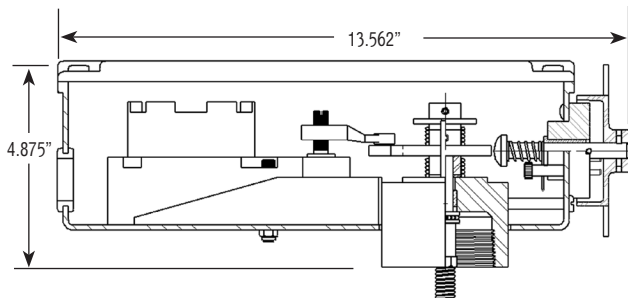

Extended Shaft

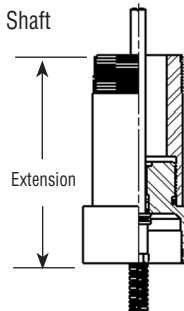

Unidirectional

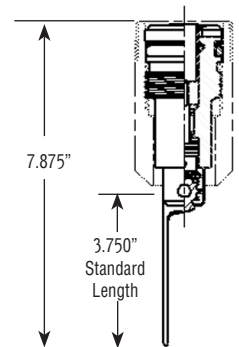

Bidirectional

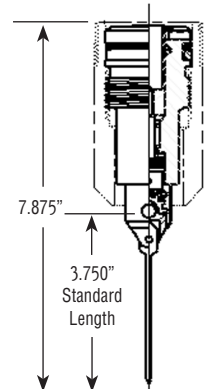

# PIG-SIG® IV Scrapper Passage Indicators

XXXX - Suffix \*

### O-Ring Material

Material Option	Part Number
0=Buna-	00-6381-0000-00
1=Buna-N (Low Temp)	00-6381-0000-01
2=Neoprene	00-6381-0000-02
3=Viton	00-6381-0000-03
5=EPDM	00-6381-0000-05
6=Kalrez	00-6381-0000-06
8=Viton GF	00-6381-0000-08
A=Viton AED	00-6381-0000-0A

### "SUFFIX" Pipe Size

Pipe Size	Pipe Wall Thickness	Length	Suffix
6" & Up	.250 to .500	4.000	-51
6" & Up	.501 to .750	3.750	-52
6" & Up	.751 to 1.000	3.500	-53
6" & Up	1.001 to 1.250	3.250	-54
6" & Up	1.251 to 1.500	3.000	-55
6" & Up	1.501 to 1.750	2.750	-56
6" & Up	.125 to .249	4.250	-64
4"	.189 to .375	4.125	-01
4"	.125 to .188	4.250	-03
5"	.189 to .375	4.125	-12
5"	.125 to .188	4.250	-13
5"	.563 to .750	3.750	-20
Less Nipple			-99

Final Assembly With Flag Indicator

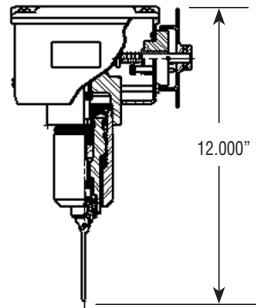

Final Assembly With Flag/ Electrical Indicator

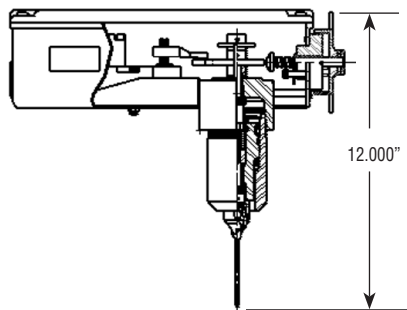

Final Assembly With Electrical Indicator

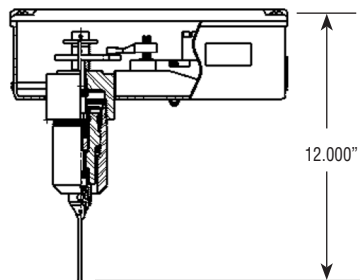

\* Please indicate if protection for environmentally harsh conditions is required.

5" & Smaller Pipe

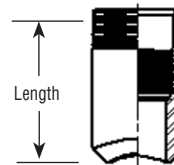

6" & Larger Pipe

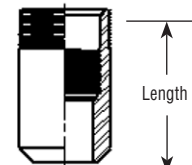

THREAD-O-RING™ Nipple part number:  
00-1023-0333-SUFFIX

### Example: 04-7778-0123-51

is a PIG-SIG with a flag indicator, 12" extended shaft, unidirectional 316 SST Plug, and Viton O-rings for 6" and larger pipe with .250" to .500" wall.



# PIG-SIG® IV Scrapper Passage Indicators

## THREAD-O-RING™ Nipple Material

Size & Grade:	2 NPS XXS ASTM A 333 Grade 6 seamless steel pipe
Tensile Requirements:	35,000 psi SMYS - 60,000 psi SMTS
Impact Requirements:	13 ft-lbf min Avg 3 Specimens 10 ft-lbf min One Specimen Only
	Impact Temperature -50° F
Chemical Requirements:	Composition, % - Carbon 0.30 max, Manganese 0.29-1.06, Phosphorus 0.025 max, Sulfur 0.025 max, Silicon 0.10 min
Test Report:	Certified Test Reports furnished per ASTM A 530

## Pressure Temperature Ratings Pressures are in pounds per square inch, gage (psig). Temperatures are in Fahrenheit.

Piping Code Temp. °F	B31.3	B31.4 F=.72	F=.72	B31.8 F=.60	F=.50	F=.40
-50	3159					
-20 to 250	3159	3743	3743	3120	2600	2080
300	3159		3620	3017	2514	2011
350	3159		3493	2911	2425	1940
400	3159		3369	2808	2340	1872
450	3072		3246	2246	1872	1497
500	2985					



# PIG-SIG® IV Scrapper Passage Indicators

## Pressure Temperature Ratings Pressures are in bar. Temperatures are in Celsius.

Piping Code Temp. °C	B31.3	B31.4 F=.72	F=.72	F=.60	B31.8 F=.50	F=.40
-46	218					
-29 to 116	218	258	258	215	179	143
149	218		250	208	173	139
177	218		241	201	167	134
204	218		232	194	161	129
262	212		224	155	129	103
260	206					

Pressures do not include allowance for corrosion. O-Ring material selection must be suitable for service fluids and temperature requirements.

## Recommended Spare Parts List

Component	Quantity/Assembly	Quantity/Spares*	Part Number
Trigger, Bidirectional	1	1	04-3633-0000-00
Trigger, Unidirectional	1	1	00-0612-0001-00
Trigger Pin	1	1	00-1598-0003-00
Gear, Uni-Directional	1	1	00-1050-0003-00
Gear, Bi-Directional	1	1	00-1050-0004-00
Pin	1	1	00-0615-0005-00
Drive Sleeve	1	1	00-3394-0001-00
Back-up Ring	1	4	00-1586-0002-00
Reset Spring	2	2	00-1486-0008-00
Needle Thrust Bearing	1	1	00-3005-0013-00
Seal Kit	1	4	See O-Ring option

\* for start-up & 2 years service Under severe start-up and/or severe operating conditions additional maintenance is required.



# PIG-SIG® IV Scrapper Passage Indicators

## Flag Indicator with Manual Reset

The basic indicator includes 2" (50 mm) THREAD-O-RING™ nipple, trigger (shaft and plug assembly with O-ring), pipe cap and flag indicator.

The extended indicator includes the same items as the flag indicator model plus an extension shaft and extension housing assembly.

Length		Weight		Part Number	
In.	mm	Lbs.	Kg.	Unidirectional	Bidirectional
Basic		9	4	04-7778-0000	04-7778-0050
Extended:					
36	900	20	9.0	04-7778-0300	04-7778-0350
48	1200	25	11.5	04-7778-0400	04-7778-0450
60	1500	29	13.0	04-7778-0500	04-7778-0550
72	1800	34	15.5	04-7778-0600	04-7778-0650

Consult the factory for larger sizes.

## Electrical Indicator with Auto Reset

The basic indicator includes: 2" (50 mm) THREAD-O-RING nipple, trigger (shaft and plug assembly with O-ring), pipe cap and electrical indicator. The electrical indicator consists of an explosion-proof microswitch (BX, double pole, double throw), cam spring, bracket, and cover.

The extended indicator includes the same items as the electrical indicator model plus an extension shaft and extension housing assembly.

Length		Weight		Part Number	
In.	mm	Lbs.	Kg.	Unidirectional	Bidirectional
Basic		11	5	04-7778-1000	04-7778-1050
Extended:					
36	900	21.5	10	04-7778-1300	04-7778-1350
48	1200	26.0	12	04-7778-1400	04-7778-1450
60	1500	30.5	14	04-7778-1500	04-7778-1550
72	1800	35.0	16	04-7778-1600	04-7778-1650

Consult the factory for larger sizes.

## Flag Indicator with Manual Reset - Electrical Indicator with Auto Reset Combined

The basic indicator includes: 2" (50 mm) THREAD-O-RING nipple, trigger (shaft and plug assembly with O-ring) pipe cap and flag/electrical indicator, combined. The electrical indicator consists of an explosion-proof microswitch (BX, double pole, double throw), cam, spring, bracket, and cover.

The extended indicator includes the same items as the flag/electrical indicator model, plus an extension shaft and extension housing assembly.

Length		Weight		Part Number	
In.	mm	Lbs.	Kg.	Unidirectional	Bidirectional
Basic		12	5.5	04-7778-2000	04-7778-2050
Extended:					
36	900	23	10.5	04-7778-2300	04-7778-2350
48	1200	28	13.0	04-7778-2400	04-7778-2450
60	1500	32	14.5	04-7778-2500	04-7778-2550
72	1800	37	17.0	04-7778-2600	04-7778-2650

Consult the factory for larger sizes.



# PIG-SIG® IV Scrapper Passage Indicators

## MICRO SWITCH Electrical Diagram

Electrical specifications:

- Double-Pole
- 2 N.O., 2 N.C.
- 3/4 in. conduit

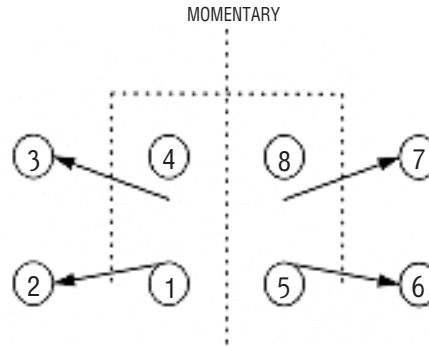

### Electrical Indicator Switch Specifications

MICRO SWITCH<sup>1</sup> weather-sealed explosion-proof switch BXP4L is designed specifically for use in hazardous location applications. The switch enclosure is sealed for protection against corrosion, water, dust and oil as defined in NEMA 1, 3, 4, 4X, 6, 7, 9 and 13 and IP67 as defined in IEC 529. The switch enclosure meets the European Hazardous Locations Designation: EExd IIC T6 category II 2 GD, SIRA 00ATEX 1037X. The switch complies with the European Directive on Equipment and Protective Systems Intended for Use in Potentially Explosive Atmospheres (94/9/EC) commonly referred to as the ATEX Directive. Compliance with the Essential Health and Safety Requirements has been assured by compliance with EN50014 1997 and EN50018 1994. The switch meets the North American Hazardous Locations Designation: Class I, Groups B, C and D; Class II, Groups E, F, and G. The switch complies with UL (File No. E61730) and CSA (File No. LR57327). The switch operating temperature range is -40°F (-40°C) to 158°F (70°C). The switch housing is epoxy coated Aluminum and Zinc with Fluorosilicone seals.

### Electrical Ratings

10 amps continuous carry. Circuits on any one pole must be the same polarity.

### AC Volts - Pilot Duty: 600 VAC, 720VA

Circuitry	VAC	Amps at 0.35 Power Factor	
		Make	Break
Double-Pole Double-Throw	120	30	3
	240	15	1.5
	480	7.5	0.75
	600	6	0.60

### DC Volts - Pilot Duty: 240 VDC, 30 watts

Circuitry	VDC	Make and Break Amps	
		Inductive	Resistive
Double-Pole Double-Throw	24	10	10
	120	0.25	0.8
	240	0.15	0.4

<sup>1</sup>MICRO SWITCH is a Honeywell Division



**T.D. Williamson, Inc.**

5110.001.03 - p8