



THREAD-O-RING™ Fittings

For Sizes: 2- and 3-inch



T.D. Williamson, Inc.

Bulletin No: 2100.001.02

Date: August 2006

Cross Indexing No: n/a

Supersedes: 2100.001.01 (4/06)



■ THREAD-O-RING™ Fittings

■ Typical Setup Using THREAD-O-RING™ Fittings

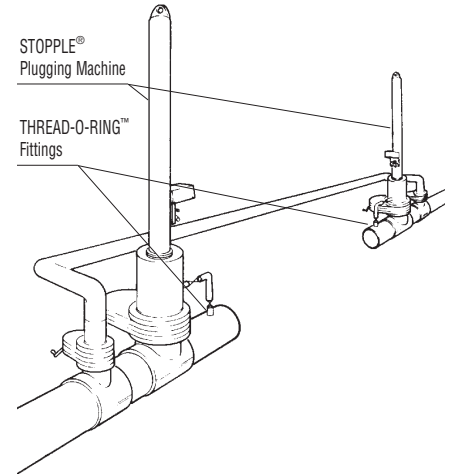

TDW THREAD-O-RING™ Fittings are used for blowdown of the isolated pipe section following a double STOPPLE® operation.

Description

THREAD-O-RING™ Fittings (T-O-R) are used with TDW STOPPLE® Plugging Machines as purge and equalization fittings. They can also be installed during new construction and used for blowdown connections on either side of a block valve. T-O-R Fittings are available in two sizes: 2" and 3" (DN 50 and DN 80).

The 2" T-O-R Fitting will accept the corrosion test coupons, thermometer wells, gauge adapters and other instrument probes.

The 2" T-O-R Fitting has a maximum operating pressure of 3600 psi (248 bar). The 3" fitting has a maximum operating pressure of 1500 psi (103 bar). Both sizes have a maximum operating temperature of 180°F (82°C).

Features

The complete THREAD-O-RING Fitting consists of: cap, plug, O-ring, and nipple.

THREAD-O-RING Fitting taps can be made without shutdown using the TDW T-101 Drilling Machine or the 360 Tapping Machine.

Two-inch T-O-R Plugs are set using either the T-101 Drilling Machine or the 360 Tapping Machine. Three-inch T-O-R Plugs can be set with the 360 Tapping Machine only.

One of the many uses of the THREAD-O-RING Fitting is as a purge and equalization fitting during plugging operations on pipelines and plant piping.

ISO 9001 Certified

Toll Free

1-888-TDWmSon (839-6766)



THREAD-O-RING™ Fittings

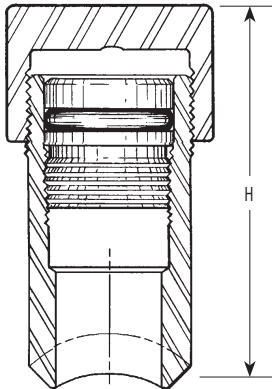

Dimensions

Size		'H' for pipe smaller than 6"		'H' for 6" and larger pipe		Min. Valve I.D.		Weight		Part Number
Inches	mm	Inches	mm	Inches	mm	Inches	mm	Lb.	Kg.	
2	50	5-5/16	135	5-3/16	132	2-1/16	52.4	6-1/2	2.9	See Chart
3	80	4-3/4	121	4-3/4	121	3-1/16	77.8	12-3/8	5.6	06-1387-0000

T R - N N B B - P M R R - C C

2" (DN 50) TDW THREAD-O-RING™ Fitting

Nipple Material

"NN"	Nipple Material	Part Number
00	Steel, Carbon ASTM A-333 GR 6	00-1023-0333-XX
01	Steel, Stainless 304L ASTM A-312	00-1023-0359-XX
02	Steel, Stainless 316L ASTM A-312	00-1023-0358-XX
03	Aluminum, 6061-T6	00-1023-0360-XX

Weld Bevel

"BB"	Part Number	Pipe Size	Detail
00	00-1023-XXXX -51	6.000 and larger	B
01	00-1023-XXXX -12	5.000 Nom. or 5.562 OD	A
02	00-1023-XXXX -03	4.000 Nom. or 4.500 OD	A
03	00-1023-XXXX -04	3.500 Nom. or 4.000 OD	A
04	00-1023-XXXX -05	3.000 Nom. or 3.500 OD	A
05	00-1023-XXXX -06	2.500 Nom. or 2.875 OD	A
06	00-1023-XXXX -07	2.000 Nom. or 2.375 OD	A



Detail A



Detail B



THREAD-O-RING™ Fittings

Threaded Cap

"CC"	Cap Material	Part Number
00	ASTM A105	00-0200-0001
02	ASTM A-312 304L SST	00-0200-0015
03	ASTM A-312 316L SST	00-0200-0021
04	Aluminum 6061-T6	00-0200-0022
06	ASTM A350 LF2	00-0200-0019

Plug Material

"PM"	Plug Material	Part Number
00	ASTM B-16 Yellow Brass (Std. Mat'l)	00-4172-0100
01	ASTM C1213/1215 CF Stl.	00-4172-0200
02	ASTM 304 CF SST	00-4172-0600
03	ASTM 316 CF SST	00-4172-0400
04	Aluminum, 6061-T6	00-4172-1200
05	ASME SA350 LF2	00-4172-0500
06	ASTM 303 CF SST	00-4172-0300
08	4140 CF Steel	00-4172-0800
12	ASTM A105 Normalized	00-4172-1300
13	ASTM B148 C95400 Al Bronze	00-4172-1400
14	ASTM B21 C46400 Naval Brass	00-4172-1500
15	ASTM 304L SST	00-4172-1600
16	ASTM A350 LF2 CL1 Normalized Per NACE MR0175	00-4172-1700

O-Ring Material

"RR"	O-Ring Material	Part Number
00	No O-Ring	N/A
01	Buna-N (Standard) N674-70	00-0118-0006
02	Viton V747-75	00-1248-0002
03	Neoprene C1276-70 (Std)	00-1947-0006
04	Ethylene Propylene E540-80 (EPDM)	00-2977-0001
05	Buna-N (Low-Temp) N103-70	00-3079-0001
06	Teflon	00-1327-0001
07	Neoprene 882-K	00-1808-0003
08	Silicone Rubber	00-3781-0006
09	Neoprene 882-P	00-4677-0006
10	Kalrez	00-4353-0001
11	Viton GF	00-6732-0002
12	Teflon Encapsulated Viton	00-6762-0002
13	Special Nitrile N-497	00-6932-0001
14	Viton V1238-95	00-8509-0002



T.D. Williamson, Inc.

2100.001.02- p4