

PE Branch Saddle-Valve Setup

Sizes: 4- inch valves with Electrofusion Branch saddles for 4-, 6- and 8-inch Polyethelene pipe



T.D. Williamson, Inc.

Data Sheet No. PESAD-VALV

Date: Novemebr 2007

Supersedes: July 2006

Tapping

Holders/Pilots:
2.79-inch (71mm) (for 4x4-inch):
05-0766-0400
3.14-inch (80mm) (for 6x4-inch and
8x4-inch): 05-0767-0600

PE Cutter
2.79-inch (71mm) (for 4x4-inch):
05-0780-1071 (See Note 2)
3.14-inch (80mm) (For 6x4-inch
and 8x4-inch): 05-0770-0080

PS2000XL Drilling Machine
05-0768-5000-00

Electrofusion Clamp
(3408 Saddles)
4-inch 06-8967-0004
6-inch 06-8967-0006

Pipeline Size:
4-inch (114mm)
6-inch (168mm)
8-inch (219mm)

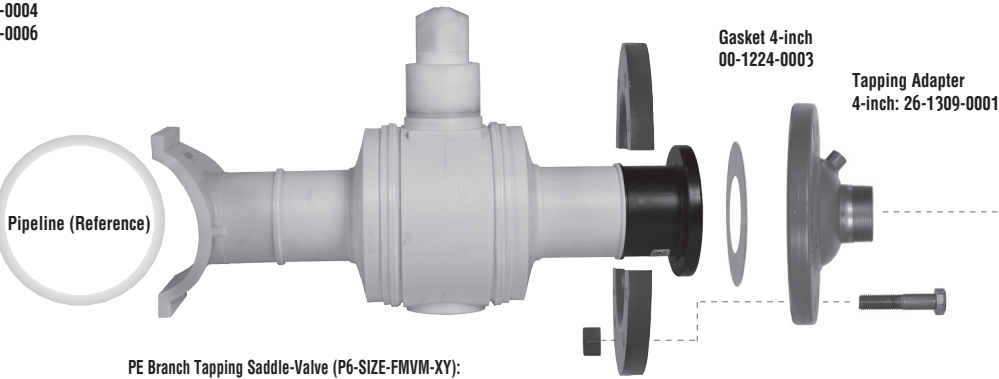

Gasket 4-inch
00-1224-0003

Tapping Adapter
4-inch: 26-1309-0001

Pipeline (Reference)

PE Branch Tapping Saddle-Valve (P6-SIZE-FMVM-XY):

Split Backup Ring Kit
4-inch: 26-1302-0010
(Includes Hardware)

Electrofusion Strap
(2406 Saddles)
4-inch 26-1302-0001
6-inch 26-1302-0002
8-inch 26-1302-0003

Notes

- 1. Maximum Working Pressure and Temperature:**
Tapping Equipment: 150 psi at 15°F - 110°F.
Saddle-Valve Fittings: MWP based on PE Material and SDR. Available in 3408 and 2406 materials.
- 2. 4x4-inch cutter provided with self-centering feature**



T.D. Williamson, Inc.

Data Sheet No. PESAD-VALV

Data Sheet No.
PESAD-VALV

PE Branch Saddle-Valve

Optional Equipment and Accessories

Purchased separately



1/4-Turn Bleeder Valve
00-7206-0022



Nipple
00-0220-0001



Standard Pipe Scraper
4-inch 08-3400-0004
6-inch 08-3400-0006



Deluxe Pipe Scraper
4-inch 08-3400-1004
6-inch 08-3400-1006
8-inch 08-3400-1008



Star Wheel Handle for T-101 XL Drilling Machine
(3/4-inch Hex Drive)
05-0768-1025

T-101-XL Drilling Machine
05-1029-0000-00 may be
used as an alternative to
PS2000XL

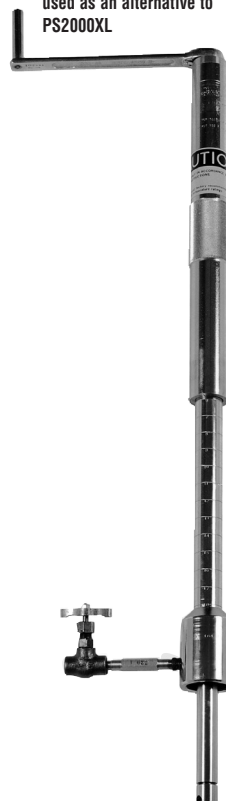

■ Note: Consult your TDW representative for additional accessories or questions. Other sizes available upon request.