

SHORTSTOPP® 300D Split Tees

Sizes: 2" through 12"



T.D. Williamson, Inc.

Bulletin No: 2100.004.04

Date: January 2011

Cross Indexing No: n/a

Supersedes: 2100.004.03 (05/10)



■ SHORTSTOPP® 300D Split Tee

Description

The SHORTSTOPP® 300D Fitting is an extruded-style split tee. The fitting is furnished with a flange that is drilled, faced, and pressure rated to match ASME Class 300 flanges. It is used with TDW plugging machines to temporarily plug the line for maintenance or repair, without shutdown. The flange is machined to accept 300D Completion Plugs.

Features

Quality control measures include inspection to ensure a proper fit on the pipeline, flange alignment verification, and radiographic weld inspection* to API Standard 1104.

The maximum operating pressure of the SHORTSTOPP® 300D Fitting is 740 psi (51 bar) at 100°F (38°C). The maximum operating temperature of the SHORTSTOPP® 300D Fitting is 180°F (82°C) at 675 psi (47 bar) per ASME B31.4. See chart on page 2 for MAOP per ASME B31.8.

All fittings are stamped with a code number for material identification, and a painted band ensures easy alignment in the field. Material certificates are available.

The 4" and larger fittings are complete with blind flange, studs, nuts, gasket, O-ring, and completion plug. The 2" and 3" sizes are furnished with a threaded cap, completion plug, and O-ring.

* 100% ultrasonic examination performed at TDW's Nivelles, Belgium plant.

■ Typical Tapping Setup

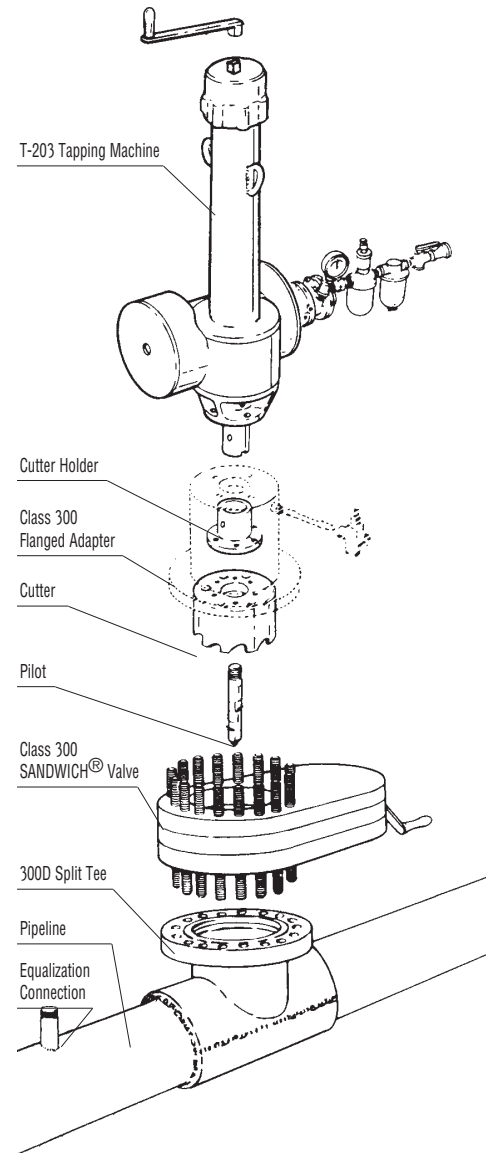

Maximum Pressure: 740 psig @ 100°F
Maximum Temperature: 180°F @ 675 psig

ISO 9001 Certified

Toll Free

1-888-TDWmSon (839-6766)



SHORTSTOPP® 300D Split Tees - .5 Design Factor

300D Split Tees Class 300

Maximum allowable operating pressure (in PSI) per ASME B31.8 at -20 to +100° F

Size		Weight		Design Factor				Part Number
Inches	DN	Lbs.	Kg.	0.72	0.60	0.50	0.40	
2	50	9	4	740	740	740	740	26-0214-0000-00
3	80	15	7	740	740	740	740	26-0215-0000-00
4	100	80	36	740	740	740	740	26-2299-0004-00
6	150	150	68	740	740	740	605	26-2299-0006-00
8	200	240	109	740	740	740	640	26-2299-0008-00
10	250	390	177	740	740	740	605	26-2299-0010-00
12	300	570	259	740	740	740	605	26-2299-0012-00

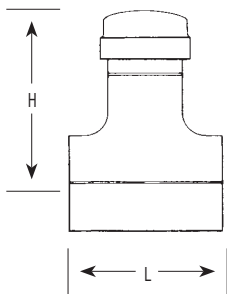

2" and 3" fittings include cap, completion plug, and O-ring.

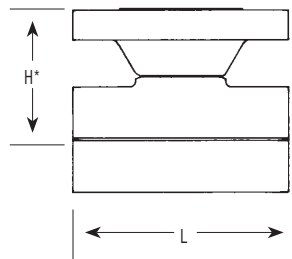

4" through 12" fittings are complete with blind flange, studs, nuts, gasket, O-ring, and completion plug.

Dimensions

Size		L		H*	
Inches	DN	Inches	mm	Inches	mm
2	50	5.75	146	5.56	141
3	80	7.67	195	11.69	297
4	100	10.75	273	6.22	158
6	150	14.00	356	7.91	201
8	200	16.50	419	9.47	240
10	250	20.00	508	11.03	280
12	300	22.00	559	12.72	323

*Does not include blind flange and gasket.

Spare O-Rings

Size		Part Number
Inches	DN	
2	50	00-0117-0010
3	80	00-0117-0013
4	100	00-1250-0001
6	150	00-1250-0002
8	200	00-1250-0003
10	250	00-1250-0004
12	300	00-1250-0005

300D Completion Plugs** Class 300

Size		Part Number	Weight	
Inches	DN		Lbs.	Kg.
2	50	07-1745-0000-00	1	0.3
3	80	07-1746-0000-00	2.1	1
4	100	07-0351-0000-00	2.5	1
6	150	07-1027-0000-00	10	5
8	200	07-1853-0000-00	20	9
10	250	07-1854-0000-00	31	14
12	300	07-1855-0000-00	44	20

**Plug setting pressure limited to pressure rating of completion machine.