



# Mechanical SHORTSLEEVE™ Fitting

## for Cast Iron Pipe, Sizes: 4" - 12"



T.D. Williamson, Inc.

Bulletin No: 2110.001.01

Date: February 2000

Cross Indexing No: n/a

Supersedes: 2110.001.00 (2/99)



■ Mechanical SHORTSLEEVE™ Fitting

### Description

Mechanical SHORTSLEEVE™ Fittings are designed for use on 4" (DN 100) through 12" (DN 300) cast iron pipe. They may be used with SHORTSTOPP® Plugging Equipment to repair or replace a damaged section of cast iron main. Mechanical SHORTSLEEVE™ Fittings can also be used without the plugging machine as a tapping fitting to install branch connections. Fittings can be purchased with or without blind flange, studs, nuts, gaskets and completion plug.

Circumferential and longitudinal sealing elements provide a continuous seal around the pipe.

### Features

The maximum recommended operating pressure is 175 psi (12 bar) at 150°F (66°C). The maximum recommended operating temperature is 180°F (82°C) at 165 psi (11 bar). When used with SHORTSTOPP® Plugging Machines, the maximum recommended pressure and temperature should be limited to that of the plugging equipment, but not exceeding that of the fitting itself as shown above. Flanges conform to ASME Class 125.

### ■ Typical Setup

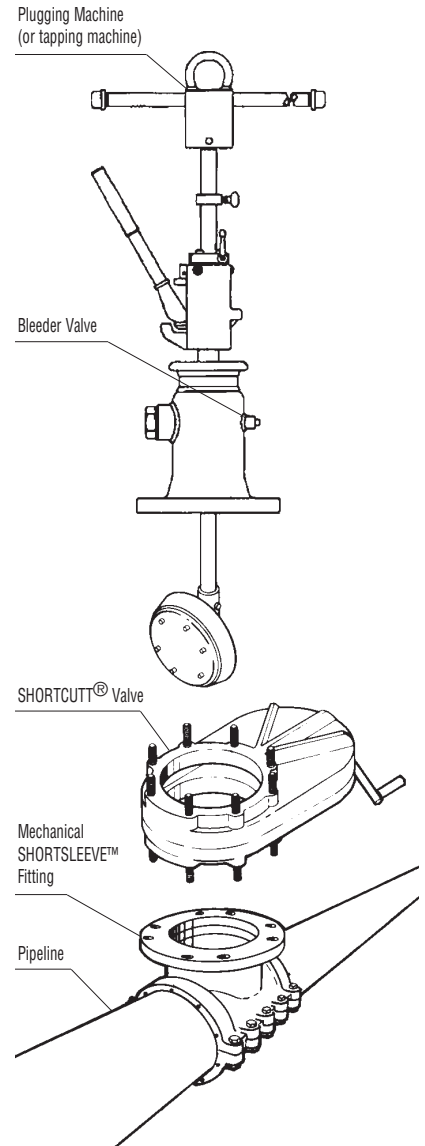

ISO 9001 Certified

Toll Free

**1-888-TDWmSon (839-6766)**



# Mechanical SHORTSLEEVE™ Fittings

Complete with Blind Flange, Studs, Nuts, Gasket and Completion Plug

## 4" through 12" (DN 100 - DN 300) Mechanical SHORTSLEEVE™ Fitting

Size		Weight		Pipe OD +/- 0.060" (1.5 mm)		Part Number
Inches	DN	Lbs.	Kg.	Inches	mm	
4	100	88	40	4.80	122	06-6586-0000
6	150	148	67	6.90	175	06-6587-0000
8	200	212	96	9.05	230	06-6588-0000
10	250	290	132	11.10	282	06-6589-0000
12	300	413	187	13.20	335	06-6590-0000

Excludes Blind Flange, Studs, Nuts, Gasket and Completion Plug

## 4" through 12" (DN 100 - DN 300) Mechanical Tapping Fitting

Size		Weight		Pipe OD +/- 0.060" (1.5 mm)		Part Number
Inches	DN	Lbs.	Kg.	Inches	mm	
4	100	63	28	4.80	122	06-7263-0000
6	150	116	53	6.90	175	06-7280-0000
8	200	127	58	9.05	230	06-7330-0000
10	250	176	80	11.10	282	06-7331-0000
12	300	280	127	13.20	335	06-7332-0000

Note: Mechanical Tapping Fittings are designed for use on cast iron pipe only.

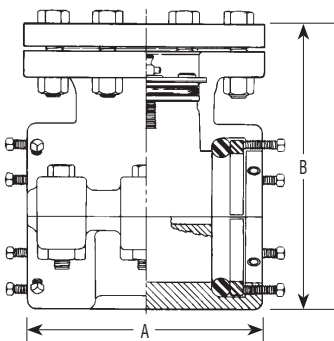

## Dimensions

Size		A		B		Min. Thru-bore	
Inches	DN	Inches	mm	Inches	mm	Inches	mm
4	100	9-1/2	241	11-3/8	289	3-29/32	99
6	150	11-7/8	301	13-3/8	340	5-29/32	150
8	200	14-7/16	367	16-3/4	425	7-13/16	198
10	250	16-7/8	428	18-3/8	467	9-13/16	249
12	300	19-15/16	506	21-3/4	552	11-13/16	300

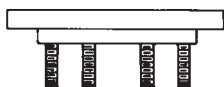

The 8" x 6" (DN 200 x DN 150) and the 12" x 10" (DN 300 x DN 250) are used to adapt valve to next smaller size Mechanical SHORTSLEEVE™.

## Valve-to-Fitting Adapters

Size	Part Number
8" x 6" (DN 200 x DN 150)*	06-1022-0000
12" x 10" (DN 300 x DN 250)	06-1024-0000

\*To be used on a SHORTSTOPP® 60 Plugging Machine only.  
If 4"-12" Jackscrew Actuator (08-0940-0000) is to be used, a spool adapter (06-1165-0043) is required.