



Mechanical SHORTSLEEVE™ Fitting

For Steel Pipe, Size: 2-inch



T.D. Williamson, Inc.

Bulletin No: 2110.002.01

Date: February 2000

Cross Indexing No: n/a

Supersedes: 2110.002.00 (2/99)

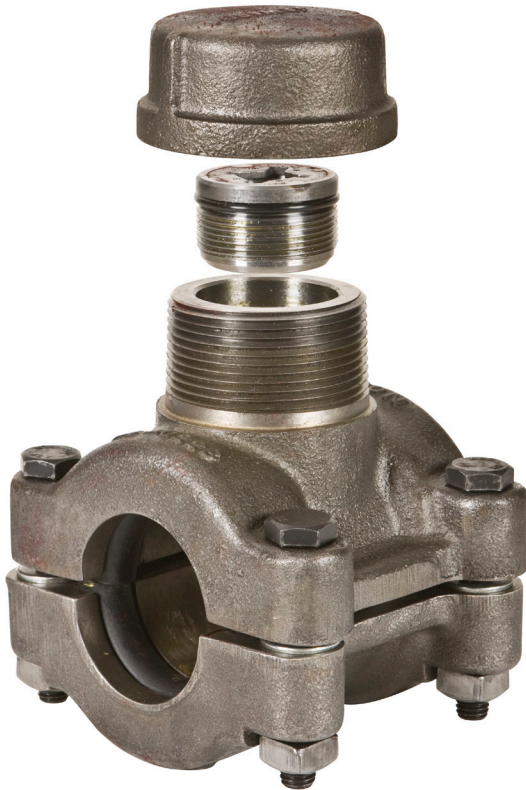

■ Mechanical SHORTSLEEVE™ Fitting

Description

Mechanical SHORTSLEEVE™ Fittings eliminate welding. They are designed for use on 2-3/8" (60 mm) OD steel pipe with the TDW SHORTSTOPP® Plugging Machine system.

Features

Circumferential and longitudinal sealing elements provide a continuous seal around the pipe. Mechanical SHORTSLEEVE™ Fittings can also be used without plugging machines to install branch connections. The maximum recommended operating pressure is 175 psi (12 bar) @ 150°F (66°C). The maximum recommended operating temperature is 180°F (82°C) @ 165 psi (11 bar). When used with the SHORTSTOPP® 60 Plugging Machine, the maximum recommended plugging pressure is 60 psi (4 bar).

■ Typical Setup

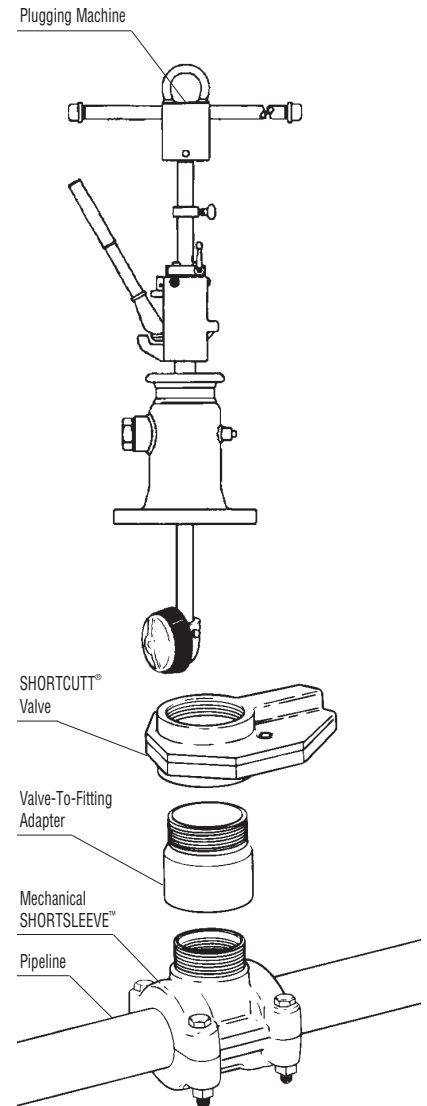

ISO 9001 Certified

Toll Free

1-888-TDWmSon (839-6766)



Mechanical SHORTSLEEVE™ Fittings For 2-inch Steel Pipe

2" Mechanical SHORTSLEEVE™ Fittings

Spare SHORTPLUG™ O-ring
00-0117-0010
Valve-To-Fitting Adapter (required)
06-1384-0001

	Part Number	Lbs.	Kg.
Complete with cap, O-ring, steel plug and cast-iron fitting	26-0228-0000	18-3/4	9
Items 1-10 below			

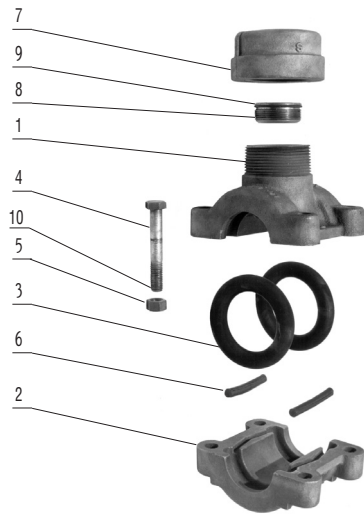

Parts and Descriptions

Item	Description	Quantity	Part Number
1	Split tee, upper half	1	26-0228-0001
2	Split tee, lower half	1	06-1288-0002
3	Split O-ring seal	4	00-1458-0011
4	Hex bolt	4	00-0681-0800-28
5	Square nut	4	00-1544-0005
6	Seal	2	00-1459-0008
7	Pipe cap	1	00-1054-0010
8	Shortplug	1	07-1745-0001
9	O-ring	1	00-0117-0010
10	Washer	4	00-0435-0006

■ Dimensions

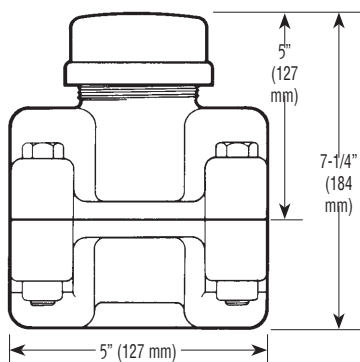

■ Typical Application

