

300D Spherical 3-WAY™ Tee

For **SHORTSTOPP®** Plugging Machines, Sizes 2- through 12-inch



T. D. Williamson, Inc.

Bulletin No: 2100.008.03

Date: May 2005

Cross Indexing No: n/a

Supersedes: 2100.008.02 (6/02)



■ **SHORTSTOPP® 300D Spherical 3-WAY™ Tee**
Sizes 2- and 3-inch



■ **SHORTSTOPP® 300D Spherical 3-WAY™ Tee**
Sizes 4- through 12-inch

Description

The **SHORTSTOPP® 300D Spherical 3-WAY™ Tee**, 4" and larger, is furnished with a flange, drilled, faced and pressure-rated to match ASME Class 300 flanges. They are used with TDW plugging machines to temporarily plug the line, without shutdown, while installing a permanent bypass. The bottom half of the fitting can be rotated for a side or a bottom outlet. The flange is machined to accept 300D Completion Plugs.

Quality control measures include inspection to ensure a proper fit on the pipeline, flange alignment verification, and radiographic weld inspection* to API Standard 1104.

*100% ultrasonic examination performed at TDW's Nivelles, Belgium plant.

Features

All fittings are stamped with a code number for material identification. Material certificates are available.

The 4" and larger fitting is complete with blind flange, studs, nuts, gasket, O-ring, and completion plug. The 2" and 3" sizes are furnished with a threaded cap, completion plug, and O-ring. The bottom half of the tee can be turned for either a side or bottom outlet. The tee can also be installed horizontally.

With plugging equipment removed, the maximum pressure is 740 psig (49 bar) at 100°F (38° C). The maximum operating temperature is 180°F (82°C) at 675 psig (45 bar) per ASME B31.4. See charts on page 2 for MAOP per ASME B31.8.

Typical Applications

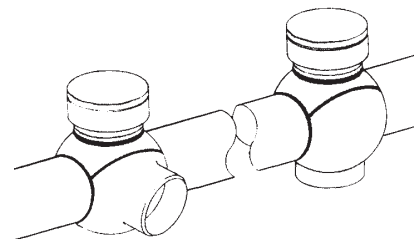

The bottom half of the tee can be turned for either a side or bottom outlet. The tee can also be installed horizontally.

*Use of **SHORTSTOPP® 275** Plugging Machines is not recommended in bottom outlet configuration.

Class 300 SANDWICH® Valve

Branch

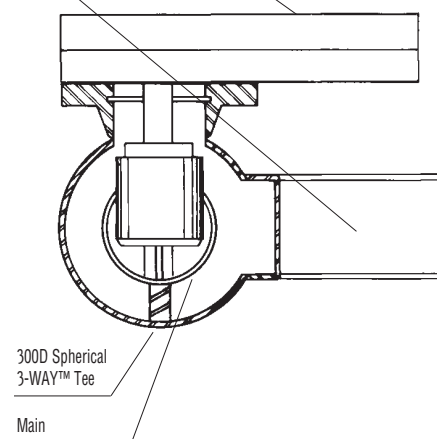

The side outlet plunger can be installed on the control bar of either the **SHORTSTOPP®** Plugging/Completion Machine or the **SHORTSTOPP®** Jackscrew Actuator, and is used on the Spherical 3-WAY™ Tee to plug the tapped hole in the main line. This stops flow into the side outlet, permitting maintenance work on the branch connection.

Maximum working pressure is 275 psi for the side outlet plunger.

ISO 9001 Certified

Toll Free
1-888-TDWmSon (839-6766)



SHORTSTOPP® 300D Spherical 3-WAY™ Tee

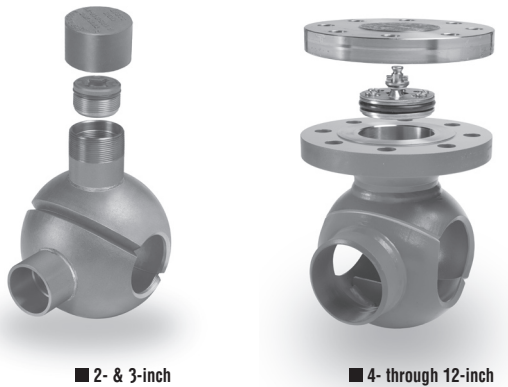

■ 2- & 3-inch

■ 4- through 12-inch

300D Spherical 3-WAY™ Tee Class 300

Maximum Allowable Operating Pressure in PSI, Per ASME B31.8 at -20 to +100° F

Size		Design Factor				Part Number	Weight	
Inches	DN	0.72	0.60	0.50	0.40		Lbs.	Kg.
2	50	740	740	740	740	26-0935-0000	17	18
3	80	740	740	740	740	26-0936-0000	23	11
4	100	740	740	740	740	26-0937-0000	80	36
6	150	740	740	659	527	06-7378-0000	156	70.8
8	200	740	684	570	456	06-7379-0000	248	112.5
10	250	740	690	575	460	26-1141-0000	364	165.1
12	300	740	630	525	420	26-1142-0000	502	227.7

The above fittings are complete with cap or blind flange, studs, nuts, gasket, O-ring, and plug.

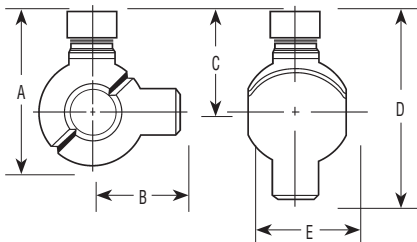

Sizes 2" (50 mm) and 3" (80 mm)

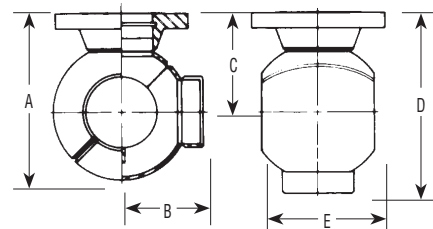

Sizes 4" (100 mm), 6" (150 mm), 8" (200 mm), 10" (250 mm) and 12" (300 mm)

Dimensions

Size		A		B		C		D		E	
Inches	DN	Inches	mm	Inches	mm	Inches	mm	Inches	mm	Inches	mm
2	50	10.468	266	4.750	121	7.156	182	11.706	302	5.844	148
3	80	13.375	340	5.625	143	9.062	230	14.688	373	7.531	191
4	100	11.281	287	5.406	137	6.968	177	12.375	314	6.906	175
6	150	15.625	397	7.750	197	9.250	235	17.000	432	10.500	267
8	200	16.875	429	8.312	211	9.875	251	18.187	462	10.562	268
10	250	20.844	529	10.406	264	11.844	301	22.250	565	13.875	352
12	300	22.844	580	11.281	287	12.844	326	24.125	613	14.812	376

Spare O-Rings

Size		Part Number
Inches	DN	
2	50	00-0117-0010
3	80	00-0117-0013
4	100	00-1250-0001
6	150	00-1250-0002
8	200	00-1250-0003
10	250	00-1250-0004
12	300	00-1250-0005

300D Completion Plugs* Class 300

Size		Part Number	Weight	
Inches	DN		Lbs.	Kg.
2	50	07-1745-0000	0.2	0.1
3	80	07-1746-0000	2	1
4	100	07-0351-0000	2.5	1
6	150	07-1027-0000	10	5
8	200	07-1028-0000	20	9
10	250	07-1029-0000	31	14
12	300	07-1030-0000	44	20

*Plug setting pressure limited to pressure rating of completion machine.