



360 Tapping Machine

Sizes: 2-inch through 6-inch



T.D. Williamson, Inc.

Bulletin No: 1000.004.03

Date: November 2008

Cross Indexing No: n/a

Supersedes: October 2005



■ **360 Tapping Machine**
Model 360a

Description

Tapping machines are used for making connections to pipelines, tanks, and plant piping without shutdown and are used to make hot taps in preparation for plugging machine applications.

Model 360 Series Tapping Machines are designed to make hot taps into pipelines, tanks and plant piping. It can be a manual, air or hydraulic driven machine used for making tank taps to 4-inch and pipe taps to 6-inch. Its maximum working pressure is 1,480 psi (100 bar) at 100°F (38°C). Its operating temperature is -20°F (-29°C) to 700°F (371°C) at 700 psi (48 bar) for intermittent service. Its maximum continuous rating is 350°F (177°C) at 1,025 psi (70 bar).

Features

The basic machine includes:

- Lower-in crank
- Measuring rod
- Ring gasket
- Bleeder valve and nipple
- Motor adapter
- Set of bolts and nuts
- LOCK-O-RING® bypass gauge

Options

T. D. Williamson, Inc., is committed to providing you with the exact product to assist you in planning, budgeting and meeting the specifications for your individual application needs. The following options are available:

- The Model 360a Tapping Machine is manually operated.
- The Model 360b Tapping Machine is air or hydraulic operated.

* For design code options not listed and additional sizes, consult your sales representative.

ISO 9001 Certified

Toll Free

1-888-TDWmSon (839-6766)

■ Typical Tapping Setup

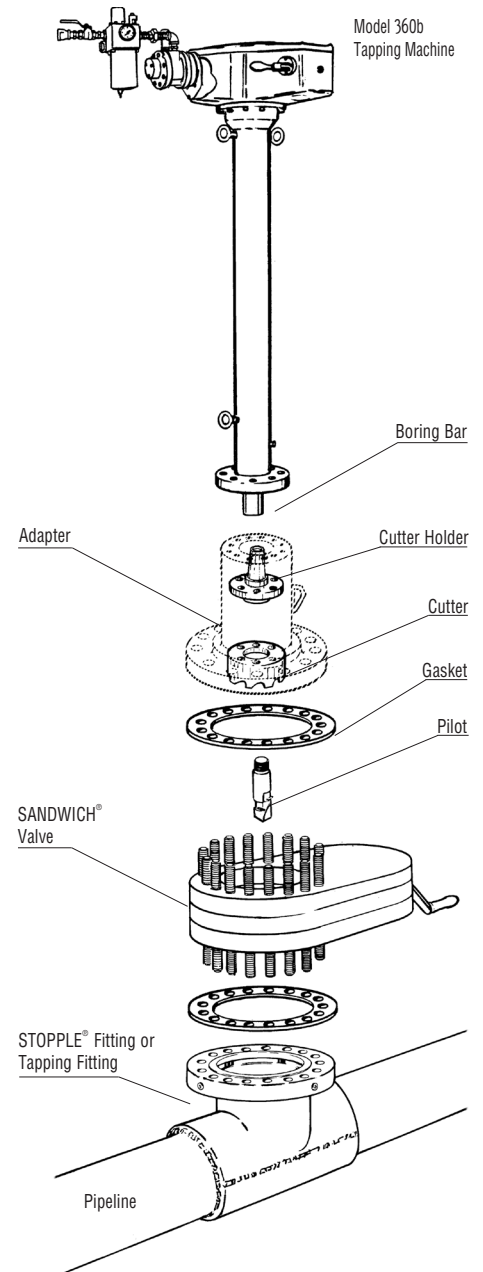



T.D. Williamson, Inc.

1000.004.03 - p2

Dimensions and Part Numbers

360 Tapping Machine

Operating Specifications

Boring Bar Travel	24" (610 mm)
Tank Taps*	to 4" (100 DN)
Pipe Taps*	to 6" (150 DN)
Max. Operating Pressure	1,480 psi (100 bar) at 100°F (38°C)
Max. Operating Temperature	700°F (371°C) at 700 psi (48 bar)**
Power	Manual, Air Motor or Hydraulic
Feed Rate	0.005" (0.127 mm) per revolution
Lower-In Crank	12 turns per inch (2 mm per turn)
Length (without measuring rod)	42-3/4" (1,086 mm)
Length (with measuring rod)	70" (1,778 mm)
Meets NACE specification	MR0175-93

* See note 4 in "Recommended Options" Chart.

** For intermittent service only. Its maximum continuous rating is 350°F (177°C) at 1,025 psi (70 bar).

Operating Options

	Manual Operation (Model 360a)			Air or Hydraulic Operation (Model 360b)		
	Lbs.	Kg.	Part Number	Lbs.	Kg.	Part Number
Tapping Machine	127	58	05-2064-0000	135	61	05-2068-0000
Steel Carrying Case	98	44	05-0026-0000	101	46	05-0029-0000
Air Motor Drive Assembly	-	-	-	40	18	05-2327-0000
Hydraulic Motor Drive Assembly	-	-	-	45	20	05-1258-0000
TOTAL WEIGHT	225	102		321	145	

The basic machine includes: Measuring rod and stop collar; Bleeder valve; Packing wrenches; Lower-in crank; Power crank.

Hydraulic Power Unit

Hydraulic Power Unit and 50' Hose w/Oil	Lbs.	Kg.	Part Number
Manual Start/Diesel	585	266	05-2017-0000
Electric Start/Diesel	600	272	05-2330-0000
Manual Start/Gas	533	242	05-2351-0000
Electric Start/Gas	550	250	05-2354-0000

* If skid is not purchased with the tapping machine, there will be a special crating charge; consult factory

Gasoline Power Unit

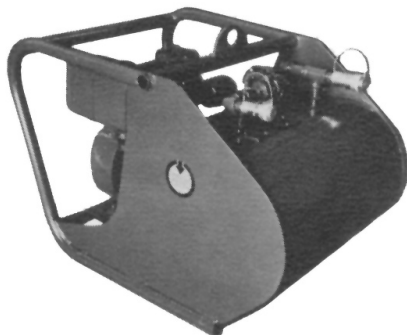

Diesel Power Unit

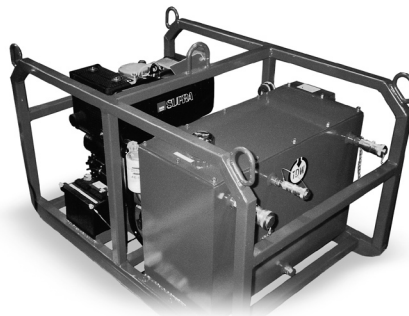

Vitalizer for Air Motor

Minimum Compressor Requirement:
105 cfm at 90 psi (6 bar).

Compressor and connecting hose
furnished by customer.

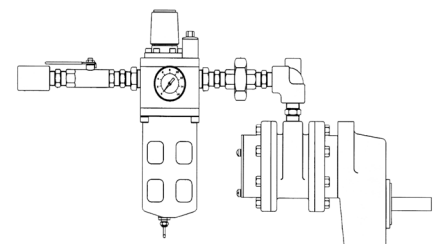



360 Tapping Machine

Adapters

Nominal Tap Size		ASME Class 150 RF Flange			ASME Class 300 RF Flange			ASME Class 600 RF Flange			600# SANDWICH® & Ball Valves		
Inches	DN	Part Number	Lbs.	Kg.	Part Number	Lbs.	Kg.	Part Number	Lbs.	Kg.	Part Number	Lbs.	Kg.
1	25	06-0027-0001	18	8	06-0028-0001	17	8	06-0030-0001	20	9	-	-	-
1-1/4	32	06-0027-0002	19	9	06-0028-0002	20	9	06-0030-0002	22	10	-	-	-
1-1/2	40	06-0027-0003	19	9	06-0028-0003	22	10	06-0030-0003	23	10	-	-	-
2	50	06-0027-0004	16	7	06-0028-0004	18	8	06-0030-0004	20	9	-	-	-
3	80	06-0027-0005	21	10	06-0028-0005	24	11	06-0030-0005	27	12	-	-	-
4	100	06-6098-0004*	32	15	06-6099-0004	42	19	06-6101-0004**	35	16	06-6097-0004	53	24
6	150	06-6098-0006*	45	20	06-6099-0006	62	28	06-6101-0006**	100	45	06-6097-0006	110	50

* Will also work on SHORTCUTT® Valves;

** See special adapters for SANDWICH® & Ball valves.

Cutter Holders, LOCK-O-RING® Holders, THREAD-O-RING™ Holders & LOCK-O-RING® Bypass Gauge

Size		Cutter Holder			LOCK-O-RING® Holders			THREAD-O-RING™ Holders			LOCK-O-RING® Bypass Gauge		
Inches	DN	Lbs.	Kg.	Part Number	Lbs.	Kg.	Part Number	Lbs.	Kg.	Part Number	Lbs.	Kg.	Part Number
2	50	-	-	-	-	-	-	1/2	0.2	05-0061-0001	1/2	0.2	07-0963-0000
3	80	2	9	05-0053-0003	-	-	-	1-1/4	0.6	05-0073-0001	-	-	-
4	100	2	9	05-0053-0003	3-1/2	2	05-0074-0000	-	-	-	-	-	-
6	150	6-1/2	3	05-0053-0002*	3-1/2	2	05-0074-0000	-	-	-	-	-	-

* Cutter holder extension (P/N 05-0071-0000) required for 6" (150 DN) ASME Class 600 taps

Twist Drills

Nominal Tap Size		Actual Size		Weight		Part Number
Inches	DN	Inches	mm	Lbs.	Kg.	Part Number
2	50	1-7/16	37	6	3	05-0046-0004

Insert Drills

Nominal Tap Size		Actual Size		Wt./Lbs.	Wt./Kg.	Part Number
Inches	DN	Inches	mm	Wt./Lbs.	Wt./Kg.	Part Number
1	25	3/4	19	2-1/2	1	05-0047-0001
1-1/4	32	1	25	4	2	05-0047-0002
1-1/2	40	1-1/4	32	5-1/2	3	05-0047-0003

Standard Accessories

Nominal Tap Size		Actual Size		Cutters			Pilot Drills			Spare U-Rods
Inches	DN	Inches	mm	Wt./Lbs.	Wt./Kg.	Part Number	Wt./Lbs.	Wt./Kg.	Part Number	Part Number
3	80	2-7/16	61.9	1	0.4	05-0001-0001	1/22	0.2	05-0293-0001	00-1424-0012
4	100	3-7/16	87.3	2	0.9	05-0328-0004	1/2	0.2	05-0293-0008	00-1424-0012
6	150	5-15/32	138.9	5-3/4	3	05-0328-0006	2	0.9	05-0293-0002	00-1424-0003

SHORTSTOPP® Accessories

Nominal Tap Size		Actual Size		Cutters			Pilot Drills			Spare U-Rods
Inches	DN	Inches	mm	Wt./Lbs.	Wt./Kg.	Part Number	Wt./Lbs.	Wt./Kg.	Part Number	Part Number
4	100	3-7/8	98.4	3-1/4	1	05-0330-0004	1/2	0.2	05-0293-0008	00-1424-0012
6	150	5-7/8	149.2	8-3/4	3	05-0330-0006	2	0.9	05-0293-0002	00-1424-0003



360 Tapping Machine

STOPPLE® Accessories

Nominal Tap Size		Actual Size		Cutters			Pilot Drills			Spare U-Rods
Inches	DN	Inches	mm	Wt./Lbs.	Wt./Kg.	Part Number	Wt./Lbs.	Wt./Kg.	Part Number	Part Number
4	100	3-15/16	100	3-1/2	2	05-0329-0004	1/2	0.2	05-0293-0008	00-1424-0012
6	150	5-15/16	150.8	9	4	05-0329-0006	2	0.9	05-0293-0002	00-1424-0003

Recommended Options for Tapping Size-On-Size

Cutter Size			
2"	3"	4"	6"
A	A	A	A
B	B	B	B
C	C	C	
D	D	D	
E	E	E	E
F	F	F	

Notes

1. The following letters represent:

A = Carbon steel pipe SMYS 30,000 to 50,000 psi maximum tensile strength of 70,000 psi.

B = Carbon steel pipe SMYS 50,000 to 70,000 psi maximum tensile strength of 90,000 psi.

C = Cast iron pipe. Cutting characteristics vary widely; hard to predict.

D = Chrome-moly, high temperature, steel pipe.

E = 300 series stainless steel pipe.

F = Flat plate cuts using special cutters on the materials listed above (refer to Notes 3 and

4). Pilot drill must be through before cutter tooth engages material.

2. The table for selecting power options (above) is based on the latest TDW designs and past experience. The data should be used as a guideline. There have been, and will be, conditions which will not strictly follow the guidelines.

3. Special cutters are available for flat plates, stainless steel pipe, cast iron pipe and other special conditions.

4. When tapping a larger pipe or tank, the cutter will sometimes go through the flat-plate condition. For example, all teeth are cutting at the same time. This is the most power-consuming condition possible and special cutters may be required.

Considering cutter size, diameter of cylinder, wall thickness, feed rates, different materials of construction, etc., the possibilities are infinite. The following table gives some examples of flat-plate conditions. Any pipe or tank with wall thicknesses greater than those shown will also be considered flat plate.

Cutter Size	Nom. Pipe x Wall	Nom. Pipe x Wall	Nom. Pipe x Wall
3"	4" x .359"	6" x .232"	8" x .176"
4"	6" x .481"	8" x .357"	10" x .282"
6"	10" x .748"	12" x .616"	14" x .556"