

SHORTSTOPP® PE System for 8-inch PE Applications



T.D. Williamson, Inc.

Data Sheet No. SS-8PE

Date: January 2010

Supersedes: November 2009

Data Sheet No. SS-8PE

Tapping



Plugging

PE Plugging Machine Assembly

**SHORTSTOPP® II 6x8-inch Plugging/
Completion Machine**
(1-5/8-inch Dia. Control Bar)
08-3508-0608

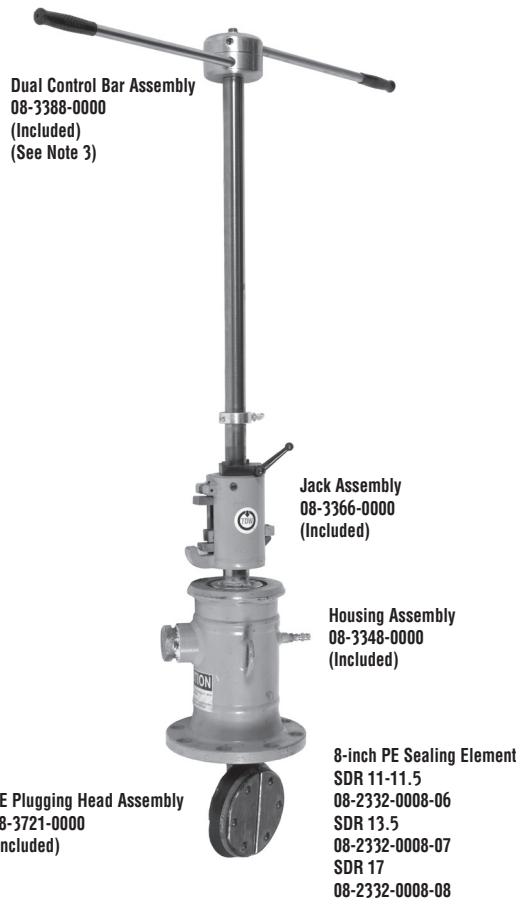

Typical Setup

6-inch (152.4 mm) SHORTSTOPP® Valve
Aluminum Body
09-0697-0000-00
Required



Adapter Spool
26-1315-0608-06



Ground Strap Kit
08-3405-0010-00

**6"x8" PE
Bottom-Out Fitting**
26-1315-0608-01

**6"x8" PE
Plugging Fitting**
26-1315-0608-00



8-inch (203.2 mm) PE Pipe

Notes

- 1. Maximum Working Pressure and Temperature of Equipment:** 150 psi at 100°F. (Except plugging components)
- 2. Plugging:** 100 psi MAOP for SDR 11 through 13.5, 70 psi maop for SDR 17.
- 3. Control bar** must have latest handle connectors. A field upgrade kit is available from TDW.



T.D. Williamson, Inc.

Data Sheet No. SS-8PE

Data Sheet No. SS-8PE

8-inch SHORTSTOPP® PE System

Optional Equipment and Accessories

Purchased separately



PS2000XL Drilling Machine

For top tap only, the PS2000XL 05-0768-5000-00 and T-101XL Drilling Machine 05-1029-0000-00 may be used as an alternative to PS2000XXL.

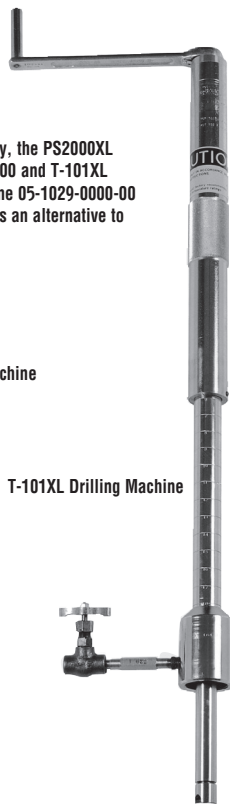

T-101XL Drilling Machine



1/4-turn Bleeder Valve
00-7206-0022



Nipple
00-0220-0001

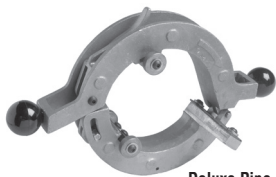

Deluxe Pipe Scraper
08-3400-1008-00

Completion

Option I



SHORTSTOPP® II 6x8
Plugging/Completion
Machine
08-3508-0608

Option II

Optional to SHORTSTOPP® II 6x8 Machine



SHORTSTOPP® 500
Completion Machine
07-1034-0000

Adapter
06-7265-0000
(Use only with
T-203 Housing)

T-203 Housing
06-1543-0000

Plug Holder
08-3396-0000

Completion Plug
Included with Fitting

Completion Plug Holder
07-0334-0000-00

Completion Plug
Included with Fitting

■ Note: Consult your TDW representative for additional fitting options.

Data Sheet No. SS-8PE