

SHORTSTOPP® PE System for 12-inch PE Applications



T.D. Williamson, Inc.

Data Sheet No. SS-12PE

Date: January 2010

Supersedes: November 2007

Data Sheet No. SS-12PE

Tapping



Plugging

PE Plugging Machine Assembly

**SHORTSTOPP® II 8x10-12-inch Plugging/
Completion Machine**
(1-5/8-inch Dia. Control Bar)
08-3508-0812

Dual Control Bar Assembly
08-3388-0000
(Included)
(See Note 4)



Typical Setup

8-inch (203.2 mm) SHORTSTOPP® Valve
Aluminum Body for PE (7.25-inch Bore)
09-0042-0000-00
Required

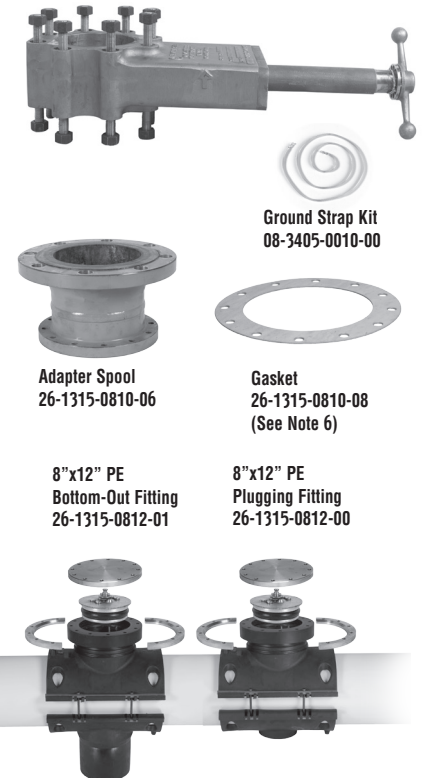

Notes

1. **Maximum Working Pressure and Temperature of Equipment:** 150 psi at 100°F.
2. **Maximum Plugging Pressure:** 60 psi MAOP
3. Control bar must have latest handle connectors. A field upgrade kit is available from TDW.
4. Gasket to be used with 26-1315-0810-06 Adaptor Spool only. Do not use gasket with completion cover.



T.D. Williamson, Inc.

Data Sheet No. SS-12PE

Data Sheet No.
SS-12PE

12-inch **SHORTSTOPP® PE System**

Optional Equipment and Accessories

Purchased separately

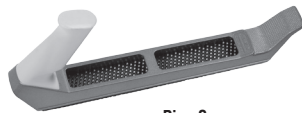

Pipe Scraper
00-5000-0936-00

Completion Options

Option I



SHORTSTOPP® II 8x10-12
Plugging/Completion Machine
08-3508-0812

Housing Assembly
08-3349-0000
(Included)



Plug Holder
08-3396-0000



Completion Plug
Included with Fitting

Option II

Optional to SHORTSTOPP® II
8x10-12 Machine

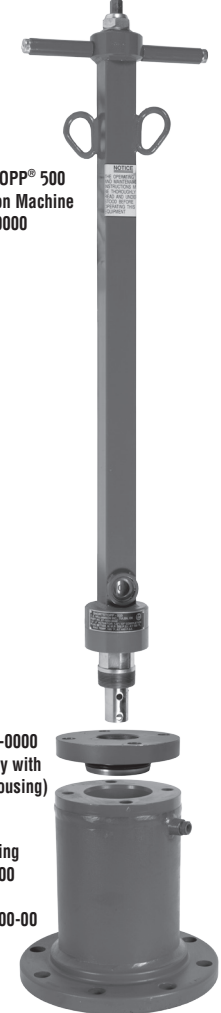

SHORTSTOPP® 500
Completion Machine
07-1034-0000

Adapter
06-7265-0000
(Use only with
T-203 Housing)

T-203 Housing
06-1544-0000
or
26-2107-0000-00
(See p.1)

Completion Plug Holder
07-0334-0000-00



Completion Plug
Included with Fitting

■ Note: Consult your TDW representative for additional fitting options.

Data Sheet No. SS-12PE