

SHORTSTOPP® II 8" x 12" Reduced Branch Plugging Machine

(2-1/2" Dia. Control Bar)



T.D. Williamson, Inc.

Data Sheet No. SSII-8x12

Date: September 2004

Supersedes: December 2003

Data Sheet No. SSII-8x12

Tapping

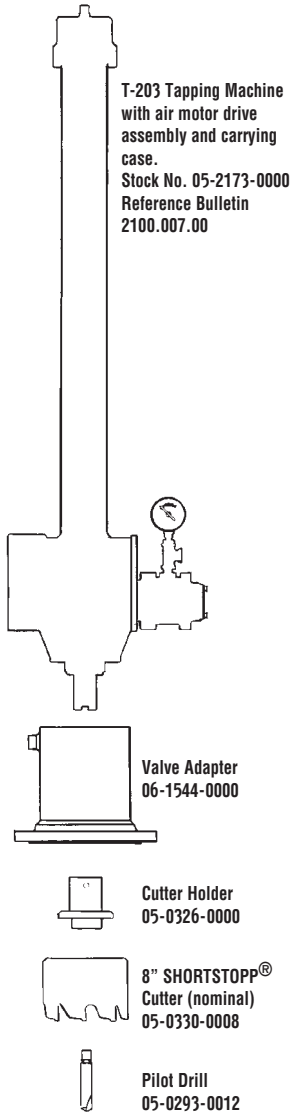

Plugging

8" x 12" Plugging Machine Assembly 08-3501-0812

Includes items below

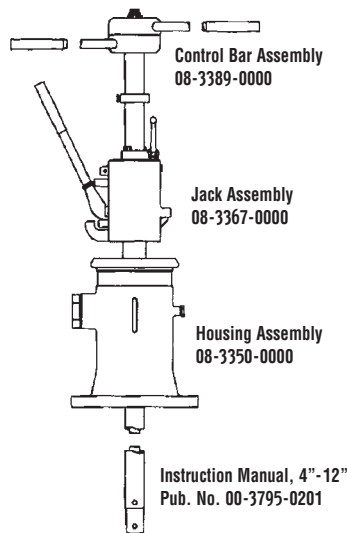

Standard Plugging Head Assembly 08-3331-0000

Includes items below



Chip Sweep (see Note 6) or Sight Glass
Sealing Element Not Included (Note 8)

Bleeder Valve Accessory

Purchased separately

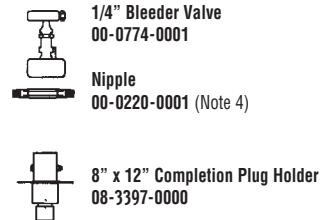

Sight Glass Kit 08-3424-0000-02 (Note 3)

See Sight Glass Data Sheet for details

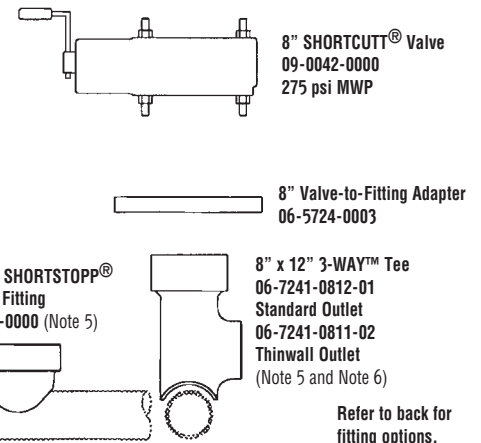

Notes

- Maximum Working Pressure and Temperature:** 150 psi at 100°F or 120 psi at 180°F. Special cups and/or nosepieces may be required (see chart at right).
- Use 8" x 12" Pilot Drill** 05-0293-0012 and **8" x 10/12" Tapping Adapter** 06-6102-0017 when making these reduced branch taps, with 660 or 760 TM.
- Sight Glass Kit** - Requires the use of the 8" T-203 Tapping Adapter. Part No. 06-1544-0000
- Bleeder valve and nipple** are provided with TDW Drilling Machines.
- Fitting** - Leaf-type completion plug and blind flange included.
- 8" Plugging Head Kit** adapts folding head plugging to plug 8" size-on-size lines and 3-WAY™ Tee Outlet. Kit 08-3420-0000 includes Plugging Head Assembly 08-3320-0000, chip sweep, and adapter.
- With an **8" x 10" Plugging Head Assembly** Nosepiece and Cups, 10" pipe can be plugged. (See 8" x 10" Data Sheet.)
- Sealing Elements** - Refer to chart at right.

Pipe ID	150 psi MWP Sealing Element	150 psi MWP Nosepiece
12.250-12.390	08-2332-0012-00	08-3331-1504
12.062-12.188	08-2332-0012-01	08-3331-1504
11.875-12.000	08-2332-0012-02	08-3331-0004
11.688-11.812	08-2332-0012-03	08-3331-0004

Consult factory for unlisted Pipe ID's.



T.D. Williamson, Inc.

Data Sheet No. **SSII-8x12**

Fittings

Tapping and **SHORTSTOPP® II** Plugging Machine 8" x 12" Gas Main



■ **Welding Fitting**
See Bulletin 2100.003.00



■ **3-WAY™ Tee**
See Bulletin 2100.002.00



■ **Branch Type II 3-WAY™ Tee**
See Bulletin 2100.011



■ **Branch Type II Plugging Fitting**
See Bulletin 2100.010

■ **Note:** Consult your TDW representative for additional fitting options.