

# SHORTSTOPP® II 8" Size-on-Size Plugging Machine

(1-5/8" Dia. Control Bar)



T.D. Williamson, Inc.

Data Sheet No. **SSII-8**

Date: September 2004

Supersedes: December 2003

## Tapping

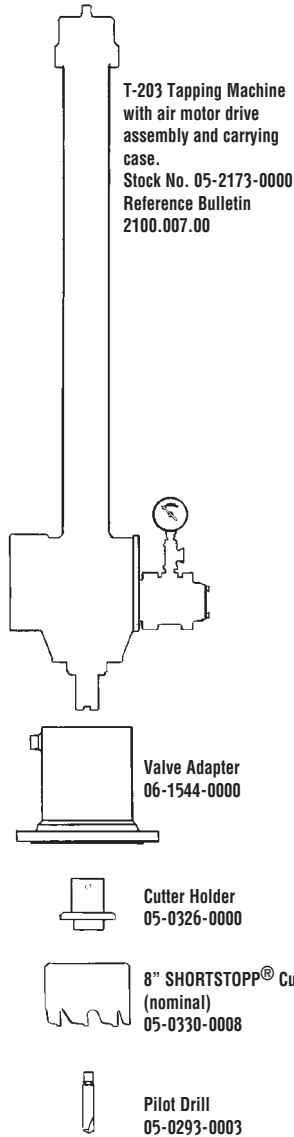

## Plugging

### 8" Plugging Machine Assembly 08-3500-0800

Includes items below

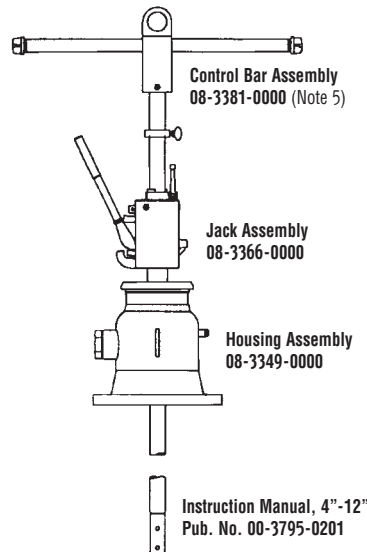

### Standard Plugging Head Assembly 08-3320-0000

Includes items below



Sealing Element Not Included (Note 6)

### Bleeder Valve Accessory

Purchased separately

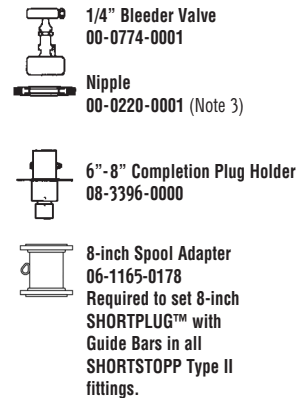

### Sight Glass Kit 08-3424-0000-02 (Note 2)

See Sight Glass Data Sheet for details

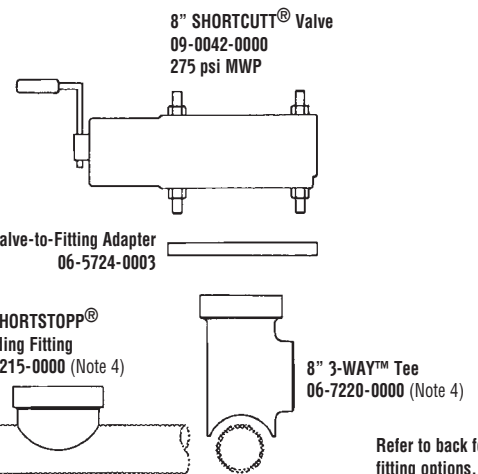

## Notes

- Maximum Working Pressure and Temperature:** 60 psi at 180°F with standard plugging head components; 150 psi at 100°F or 120 psi at 180°F, with special cups/nosepieces (see chart at right).
- Sight Glass Kit** - Requires the use of the 8" T-203 Tapping Adapter. Part No. 06-1544-0000.
- Bleeder valve and nipple** are provided with TDW Drilling Machines.
- Fitting** - Leaf-type completion plug and blind flange included.
- 6" x 8" Control Bar Assembly** may also be used.
- Sealing Elements** - Refer to chart at right.

| Pipe ID     | 60 psi MWP Sealing Element | 60 psi MWP Nosepiece | Pipe ID     | 150 psi MWP Sealing Element | 150 psi MWP Nosepiece |
|-------------|----------------------------|----------------------|-------------|-----------------------------|-----------------------|
| 8.250-8.280 | 08-1719-0008-01            | 08-3320-1502         | 8.281-8.311 | 08-3428-0008-01             | 08-3320-1502          |
| 8.188-8.249 | 08-1719-0008-02            | 08-3320-1502         | 8.250-8.280 | 08-3428-0008-02             | 08-3320-1502          |
| 7.938-8.281 | 08-0114-0008-00            | 08-3320-0002         | 7.981-8.000 | 08-3427-0008-00             | 08-3320-0002          |
| 7.625-7.687 | 08-0114-0008-05            | 08-3320-0002         | 7.625-7.687 | 08-3427-0008-06             | 08-3320-0002          |

Consult factory for unlisted pipe ID.



T.D. Williamson, Inc.

Data Sheet No. SSII-8

# Fittings

## Tapping and SHORTSTOPP® II Plugging Machine 8" Gas Main



■ Welding Fitting and SHORTPLUG™ with Guide Bars  
See Bulletin 2100.013

■ Welding Fitting  
See Bulletin 2100.003

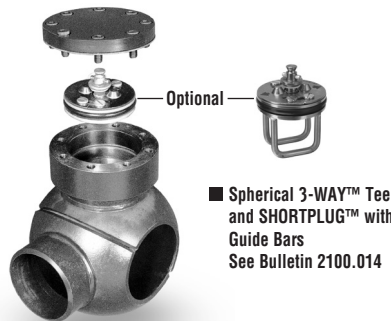

■ Spherical 3-WAY™ Tee and SHORTPLUG™ with Guide Bars  
See Bulletin 2100.014

■ Spherical 3-WAY™ Tee  
See Bulletin 2100.007

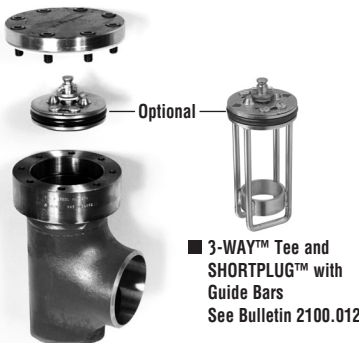

■ 3-WAY™ Tee and SHORTPLUG™ with Guide Bars  
See Bulletin 2100.012

■ 3-WAY™ Tee  
See Bulletin 2100.002



■ Mechanical SHORTSLEEVE™ Fitting  
See Bulletin 2110.001



■ Branch Type II 3-WAY™ Tee  
See Bulletin 2100.011



■ Branch Type II Plugging Fitting  
See Bulletin 2100.010

■ Note: If you already have 8" SHORTSTOPP® II plugging equipment, the additional accessories shown below are all that are needed to plug 6" mains (plus Welding Fittings).

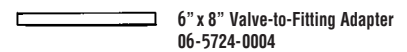

6" x 8" Valve-to-Fitting Adapter  
06-5724-0004

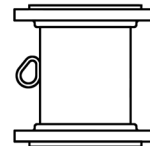

8-inch Spool Adapter  
06-1165-0178  
Required to set 8-inch SHORTPLUG™ with Guide Bars in all SHORTSTOPP Type II fittings.



6" SHORTSTOPP® Cutter (nominal)  
05-0446-0006



Pilot Drill  
05-0293-0002



Completion Plug Holder  
08-3396-0000



6" Plugging Head with Sealing Cup and Chip Sweep  
08-3318-0000

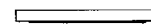

Cover Flange



Completion Plug

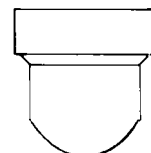

Fitting

6" Welding Fitting includes: cover flange with bolts, gasket and plastic caplugs, completion plug and O-ring.  
Stock No. 06-5713-0000

■ Note: Consult your TDW representative for additional fitting options.