

SHORTSTOPP® II 6" x 8" Reduced Branch Plugging Machine

(1-5/8" Dia. Control Bar)



T.D. Williamson, Inc.

Data Sheet No. SSII-6x8

Date: September 2004

Supersedes: December 2003

Data Sheet No. SSII-6x8

Tapping

■ Note: Either the T-101 XL or T-203 Tapping Machine is recommended for 6" taps.

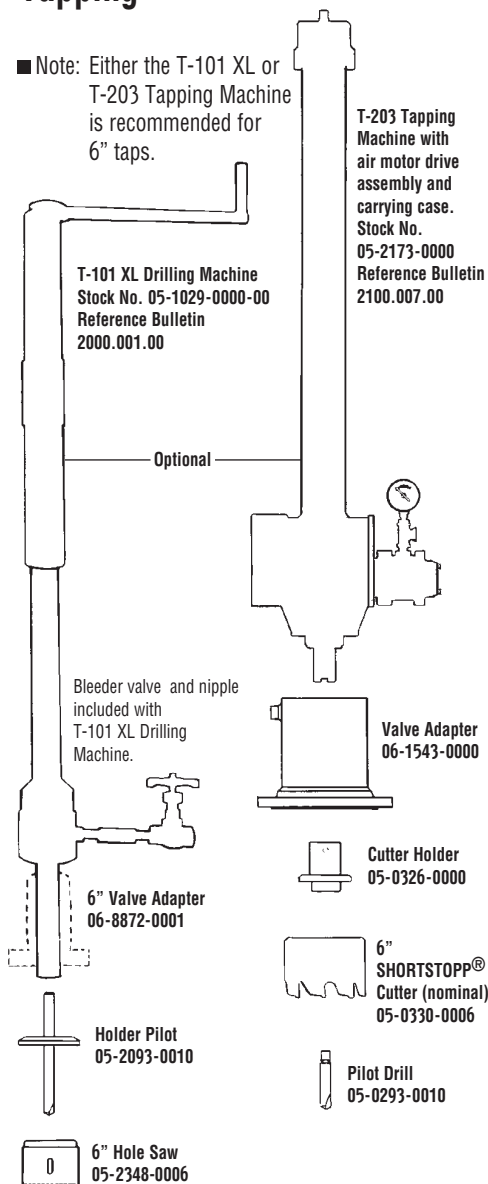

Plugging

6" x 8" Plugging Machine Assembly 08-3501-0608

Includes items below

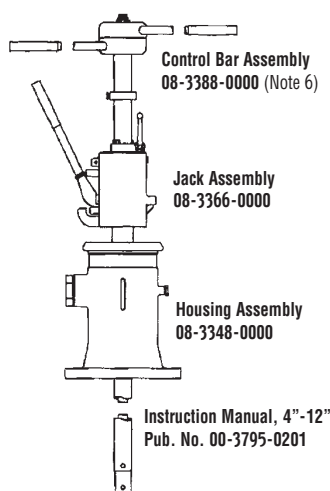

Standard Plugging Head Assembly 08-3329-0000

Includes items below



Chip Sweep (see Note 6) or Sight Glass
Sealing Element Not Included (Note 7)

Bleeder Valve Accessory

Purchased separately

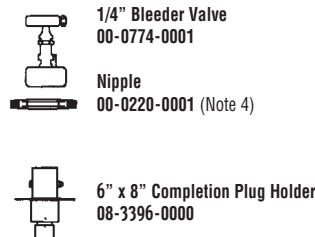

Sight Glass Kit 08-3424-0000-02 (Note 3)

See Sight Glass Data Sheet for details

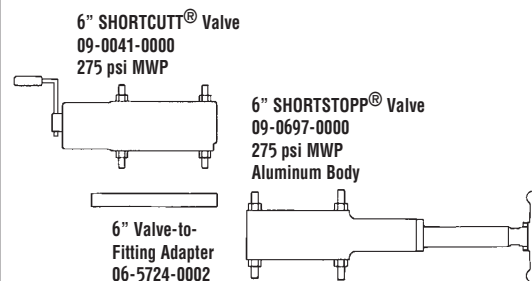

6" x 8" SHORTSTOPP® Welding Fitting
06-9542-0000 (Note 5)

6" x 8" 3-WAY™ Tee
06-7240-0608-01
Standard Outlet
06-7240-0608-02
Thinwall Outlet
(Note 5 and Note 6)

8" Steel Pipe

Refer to back for fitting options.

Notes

- Maximum Working Pressure and Temperature:** 150 psi at 100°F or 120 psi at 180°F. Special cups and/or nosepieces may be required (see chart at right).
- Use 6" x 8" Pilot Drill** 05-0293-0010 when making these reduced branch taps.
- Sight Glass Kit** - Requires the use of the 6" T-203 Tapping Adapter. Part No. 06-1543-0000
- Bleeder valve and nipple** are provided with TDW Drilling Machines.
- Fitting** - Leaf-type completion plug and blind flange

- included.
- Control bar** can be used with 6" plugging head 08-3318-0000 (includes chipsweep) to plug 6" size-on-size lines and 3-WAY™ Tee Outlet.
- Sealing Elements** - Refer to chart at right.

Pipe ID	150 psi MWP Sealing Element	150 psi MWP Nosepiece
8.250-8.329	08-2332-0008-00	08-3329-1504
8.062-8.188	08-2332-0008-01	08-3329-1504
7.875-8.000	08-2332-0008-02	08-3329-0004
7.625-7.812	08-2332-0008-03	08-3329-0004

Consult factory for unlisted Pipe ID's.



T.D. Williamson, Inc.

Data Sheet No. SSII-6x8

Fittings

Tapping and *SHORTSTOPP*® II Plugging Machine 6" x 8" Gas Main



■ **Welding Fitting**
See Bulletin 2100.003.00



■ **3-WAY™ Tee**
See Bulletin 2100.002.00



■ **Branch Type II 3-WAY™ Tee**
See Bulletin 2100.011



■ **Branch Type II Plugging Fitting**
See Bulletin 2100.010

■ **Note:** Consult your TDW representative for additional fitting options.