

SHORTSTOPP® II 6" Size-on-Size Plugging Machine

(1-5/8" Dia. Control Bar)



T.D. Williamson, Inc.

Data Sheet No. SSII-6

Date: September 2004

Supersedes: December 2003

Tapping

■ Note: Either the T-101 XL or T-203 Tapping Machine is recommended for 6" taps.

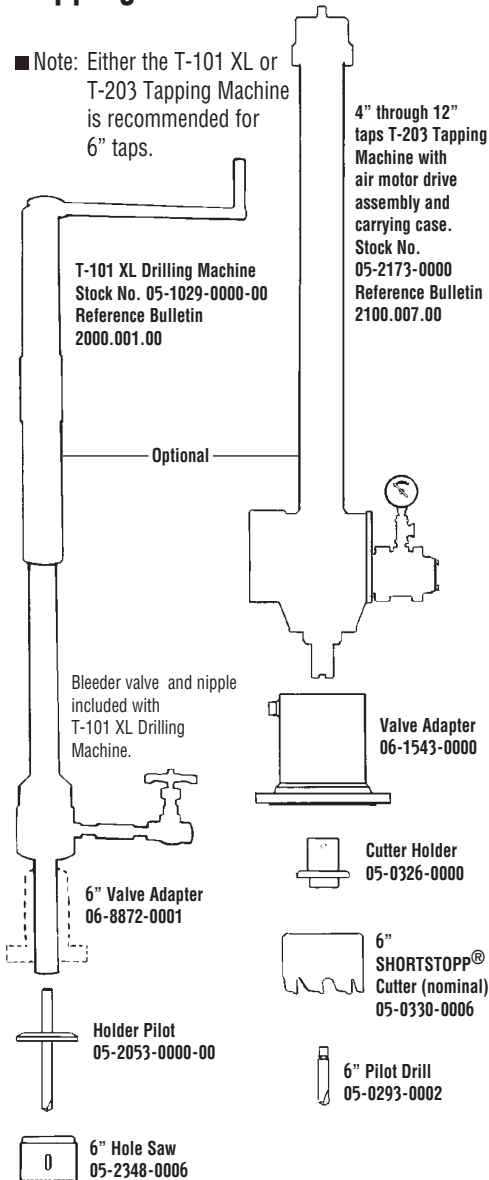

Plugging

6" Plugging Machine Assembly 08-3500-0600

Includes items below

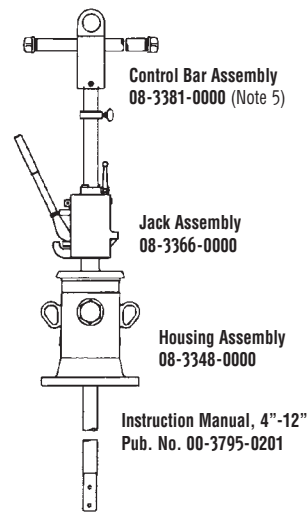

Standard Plugging Head Assembly 08-3318-0000

Includes items below

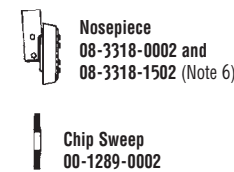

Sealing Element Not Included (Note 6)

Bleeder Valve Accessory

Purchased separately

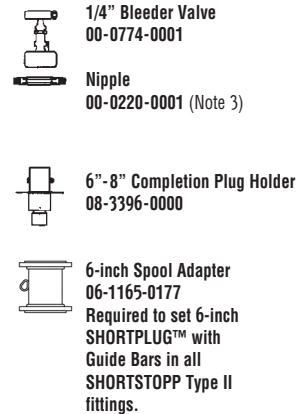

Sight Glass Kit 08-3424-0000-02 (Note 2)

See Sight Glass Data Sheet for details

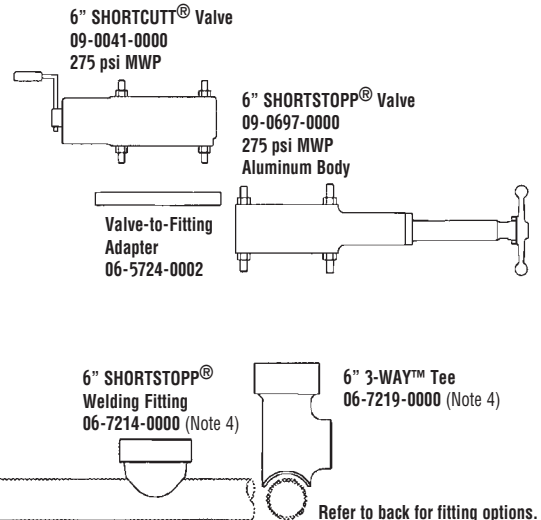

Notes

1. **Maximum Working Pressure and Temperature:** 60 psi at 180°F with standard plugging head components; 200 psi at 100°F or 120 psi at 180°F, with special cups/nosepieces (see chart at right).
2. **Sight Glass Kit** - Requires the use of the 6" T-203 Tapping Adapter. Part No. 06-1543-0000.
3. **Bleeder valve and nipple** are provided with TDW Drilling Machines.
4. **Fitting** - Leaf-type completion plug and blind flange included.
5. 6" x 8" **Control Bar Assembly** 08-3388-0000 may also be used.
6. **Sealing Elements** - Refer to chart at right.

Pipe ID	60 psi MWP Sealing Element	60 psi MWP Nosepiece	Pipe ID	200 psi MWP Sealing Element	200 psi MWP Nosepiece
6.250-6.311	08-0502-0006-01	08-3318-1502	6.250-6.311	08-3428-0006-01	08-3318-1502
6.188-6.249	08-0502-0006-02	08-3318-1502	6.187-6.249	08-3428-0006-02	08-3318-1502
6.062-6.310	08-0114-0006-00	08-3318-0002	6.062-6.124	08-3428-0006-04	08-3318-1502
5.750-5.811	08-0114-0006-04	08-3318-0002	5.750-5.811	08-3427-0006-04	08-3318-0002

Consult factory for unlisted pipe ID.



T.D. Williamson, Inc.

Data Sheet No. **SSII-6**

Fittings

Tapping and **SHORTSTOPP**® II Plugging Machine 6" Gas Main

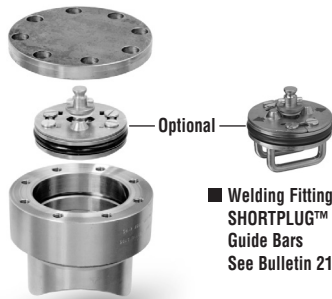

Optional

■ **Welding Fitting and SHORTPLUG™ with Guide Bars**
See Bulletin 2100.013

■ **Welding Fitting**
See Bulletin 2100.003



Optional

■ **Spherical 3-WAY™ Tee and SHORTPLUG™ with Guide Bars**
See Bulletin 2100.014

■ **Spherical 3-WAY™ Tee**
See Bulletin 2100.007

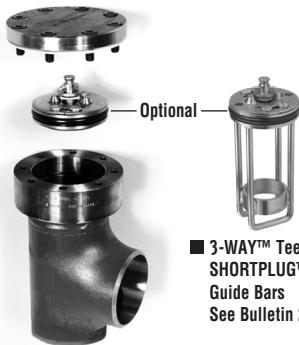

Optional

■ **3-WAY™ Tee and SHORTPLUG™ with Guide Bars**
See Bulletin 2100.012

■ **3-WAY™ Tee**
See Bulletin 2100.002



■ **Mechanical SHORTSLEEVE™ Fitting**
See Bulletin 2110.001



■ **Branch Type II 3-WAY™ Tee**
See Bulletin 2100.011



■ **Branch Type II Plugging Fitting**
See Bulletin 2100.010

■ **Note:** If you already have 8" **SHORTSTOPP**® plugging equipment, the additional accessories shown below are all you need to plug 6" mains (plus Welding Fittings).

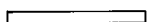
 **6" x 8" Valve-to-Fitting Adapter**
06-5724-0004

 **6-inch Spool Adapter**
06-1165-0177
Required to set 6-inch **SHORTPLUG**™ with Guide Bars in all **SHORTSTOPP** Type II fittings.

 **6" **SHORTSTOPP**® Cutter (nominal)**
05-0446-0006

 **Pilot Drill**
05-0293-0002

 **Completion Plug Holder**
08-3396-0000

  **6" Plugging Head with Sealing Cup and Chip Sweep**
08-3318-0000

 **Cover Flange**

 **Completion Plug**

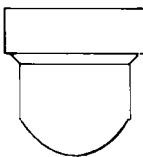
 **Fitting**
6" Welding Fitting includes: cover flange with bolts, gasket and plastic caplugs, completion plug and O-ring.
Stock No. 06-5713-0000

■ **Note:** Consult your TDW representative for additional fitting options.