

SHORTSTOPP® II 4-inch Size-on-Size Plugging Machine

(1-inch Dia. Control Bar)



T.D. Williamson, Inc.

Data Sheet No. **SSII-4**

Date: September 2004

Supersedes: December 2003

Tapping

■ Note: Either the T-101 or T-203 Tapping Machine is recommended for 4" taps.

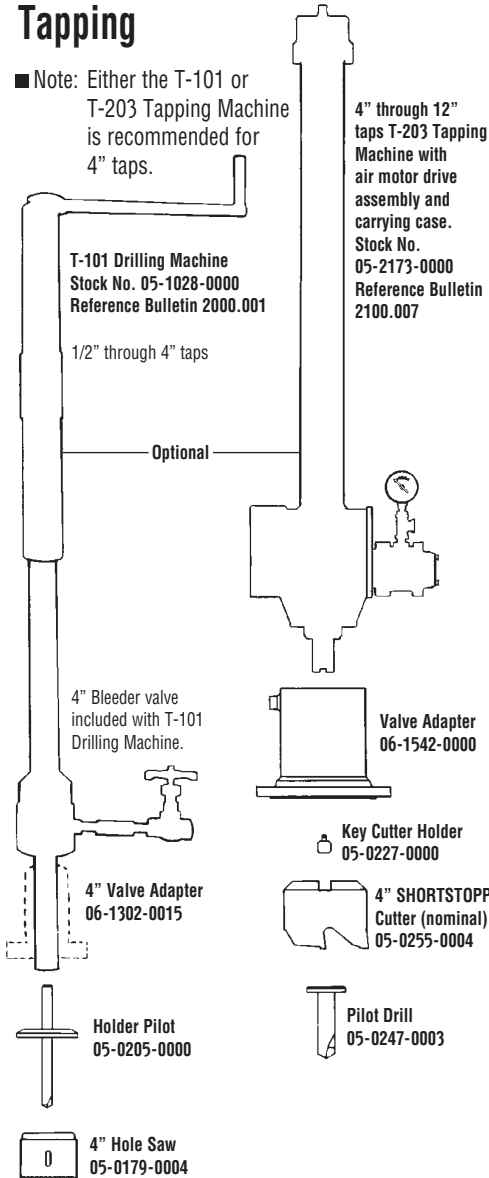

Plugging

4" Plugging Machine Assembly 08-3500-0400

Includes items below

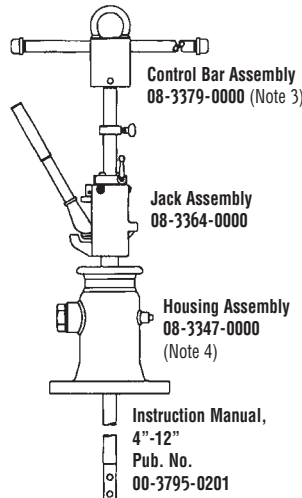

Standard Plugging Head Assembly 08-3316-0000

Includes items below

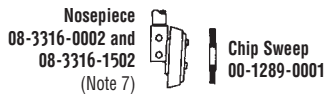

Sealing Element Not Included (Note 7)

Bleeder Valve Accessory

Purchased separately

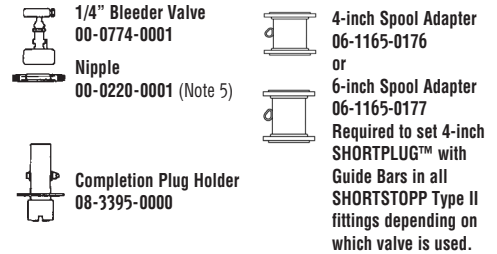

Sight Glass Kit 08-3424-0000-01 (Note 2)

See Sight Glass Data Sheet for details

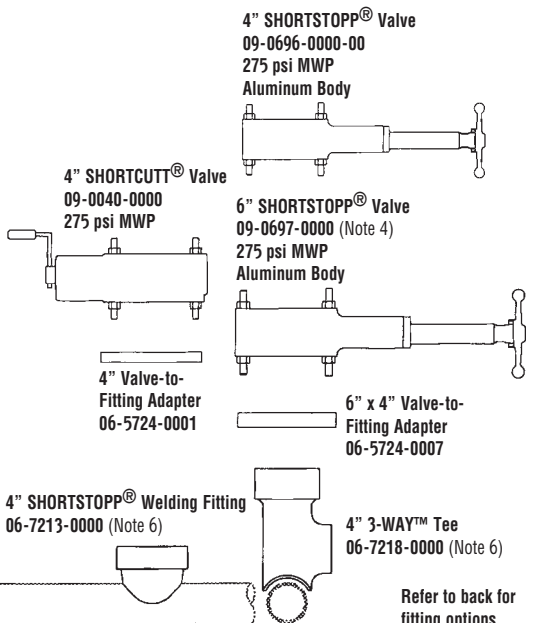

Notes

- Maximum Working Pressure and Temperature:** 60 psi at 180°F with standard plugging head components; 200 psi at 100°F or 120 psi at 180°F, with special cups/nosepieces (see chart at right).
- Sight Glass Kit** - Requires the use of a T-203 Tapping Adapter. 4" Part No. 06-1542-0000 6" Part No. 06-1543-0000.
- 3" x 4" Control Bar Assembly** may also be used 08-3386-0000.
- If using a 6" **SHORTCUTT®** or **SHORTSTOPP®** Valve, use 4-6 PE Housing Assembly 08-3357-0000 and use 6" x 4" Tapping Adapter (f/T-101) 06-8872-0005.
- Bleeder valve and nipple** are provided with TDW Drilling Machines.
- Fitting** - Leaf-type completion plug and blind flange included.
- Sealing Elements** - Refer to chart at right. Use 08-3428-0004-03 to plug 4" 3-way tee outlet.

Pipe ID	60 psi MWP Sealing Element	60 psi MWP Nosepiece	Pipe ID	200 psi MWP Sealing Element	200 psi MWP Nosepiece
4.250-4.260	08-0502-0004-00	08-3316-1502	4.156-4.260	08-3428-0004-01	08-3316-1502
4.124-4.187	08-0502-0004-02	08-3316-1502	4.062-4.156	08-3428-0004-02	08-3316-1502
4.026-4.188	08-0114-0004-00	08-3316-0002	3.962-4.125	08-3428-0004-03	08-3316-1502
3.812-3.874	08-0114-0004-03	08-3316-0002	3.875-3.937	08-3427-0004-02	08-3316-0002
Consult factory for unlisted pipe ID.					
			3.812-3.874	08-3427-0004-03	08-3316-0002
			3.750 - 3.811	08-3427-0004-04	08-3316-0002



T.D. Williamson, Inc.

Data Sheet No. SSII-4

Fittings

Tapping and SHORTSTOPP® II Plugging Machine 4-inch Gas Main

Data Sheet No. SSII-4

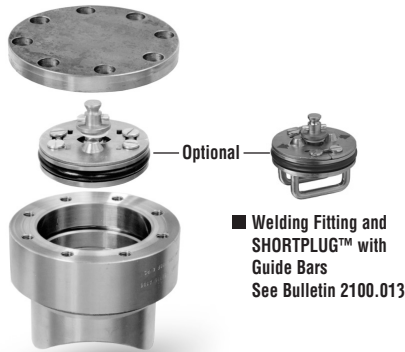

Optional

■ Welding Fitting and SHORTPLUG™ with Guide Bars
See Bulletin 2100.013

■ Welding Fitting
See Bulletin 2100.003

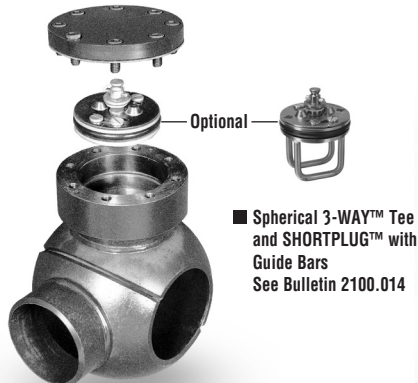

Optional

■ Spherical 3-WAY™ Tee and SHORTPLUG™ with Guide Bars
See Bulletin 2100.014

■ Spherical 3-WAY™ Tee
See Bulletin 2100.007



Optional

■ 3-WAY™ Tee and SHORTPLUG™ with Guide Bars
See Bulletin 2100.012

■ 3-WAY™ Tee
See Bulletin 2100.002



■ Mechanical SHORTSLEEVE™ Fitting
See Bulletin 2110.001



■ Branch Type II 3-WAY™ Tee
See Bulletin 2100.011



■ Branch Type II Plugging Fitting
See Bulletin 2100.010

■ Note: Consult your TDW representative for additional fitting options.