

SHORTSTOPP® II 1-1/4-inch Plugging Machine



T.D. Williamson, Inc.

Data Sheet No. **SSII-1-1/4**

Date: December 2010

Supersedes: September 2004

Tapping

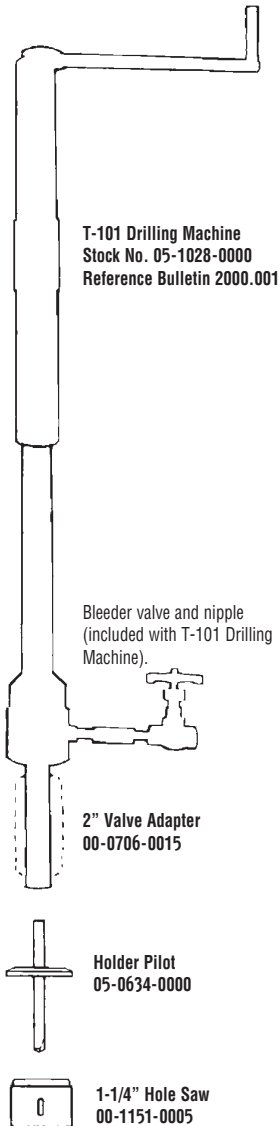

Plugging

1-1/4" Plugging Machine Assembly 08-3303-0000

Includes items below

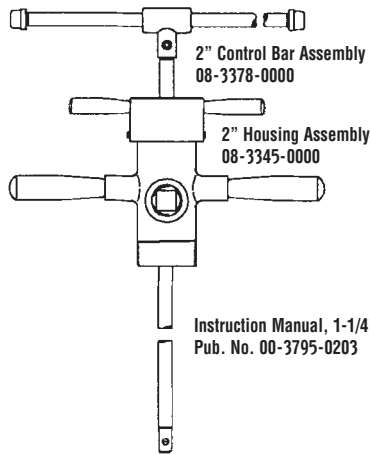

1-1/4" Plugging Head Assembly 08-3302-0000

Includes items below

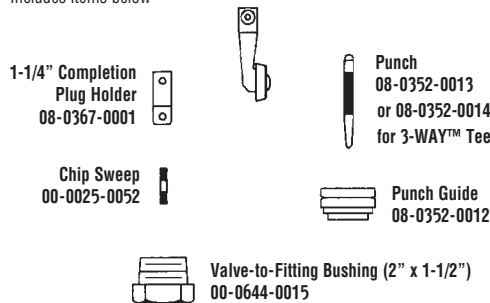

Sealing Element Not Included (Note 5)

Bleeder Valve Accessory

Purchased separately

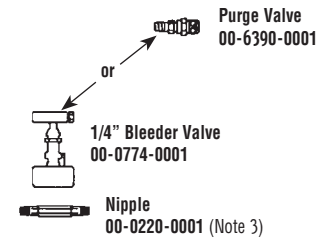

Carrying case for plugging machine
sold separately 08-2481-0006

2" SHORTCUTT® 500 Valve
09-0758-0000
500 psi MWP



1-1/4" 3-WAY™ Tee
06-6741-0000 (Note 4)

1-1/4" Welding Fitting
06-1179-0000 (Note 4)

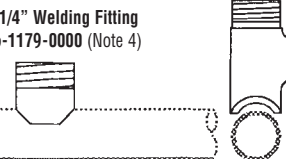

1-1/4" Steel Pipe

Refer to back for fitting options.

Notes

- Maximum Working Pressure:** 200 psi at 100°F (May be limited by valve selection.)
- Maximum Working Temperature:** 180°F at 120 psi.
- Bleeder valve and nipple** are provided with TDW Drilling Machines.
- Fitting** - Includes threaded completion plug and cap.
- Sealing Elements** - Refer to chart at right.

Pipe ID	Part No.
1.312-1.380	08-0114-0125-00
1.250-1.311	08-0114-0125-01

Consult factory for unlisted pipe ID.



T.D. Williamson, Inc.

Data Sheet No. **SSII-1-1/4**

Fittings

Tapping and *SHORTSTOPP*® II Plugging Machine

1-1/4-inch Gas Main



■ **Welding Fitting**
See Bulletin 2100.003



■ **3-WAY™ Tee**
See Bulletin 2100.002

■ **Note:** Consult your TDW representative for additional fitting options.