

# Tapping and SHORTSTOPP® 60 Plugging Machine

*Equipment Needed to Plug a 8" Gas Main*



T.D. Williamson, Inc.

Data Sheet No. **SS60-8**

Date: September 2004

Supersedes: March 1999

## Tapping

- Note: If you need 6" SHORTSTOPP® plugging equipment, see back of Product Data Sheet.

T-203 Tapping Machine with air motor drive assembly and carrying case.  
Stock No. 05-2173-0000  
Reference Bulletin 2100.007.00

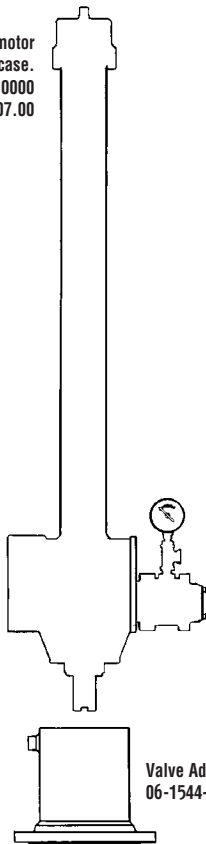

Valve Adapter  
06-1544-0000



Cutter Holder  
05-0326-0000



8" SHORTSTOPP®  
Cutter (nominal)  
05-0330-0008



Pilot Drill  
05-0293-0003

## Plugging

Plugging Machine  
Reference Bulletin 2020.001.00

Bleeder Valve\*  
00-0774-0001  
Nipple\*  
00-0220-0001

\*Not included with machine.

8" SHORTSTOPP® 60 Plugging Machine includes: plugging head, chip sweep and housing. Stock No. 08-0102-0000

Note: The plugging machine can be converted to a completion machine by removing two bolts and replacing the plugging head with a completion plug holder.

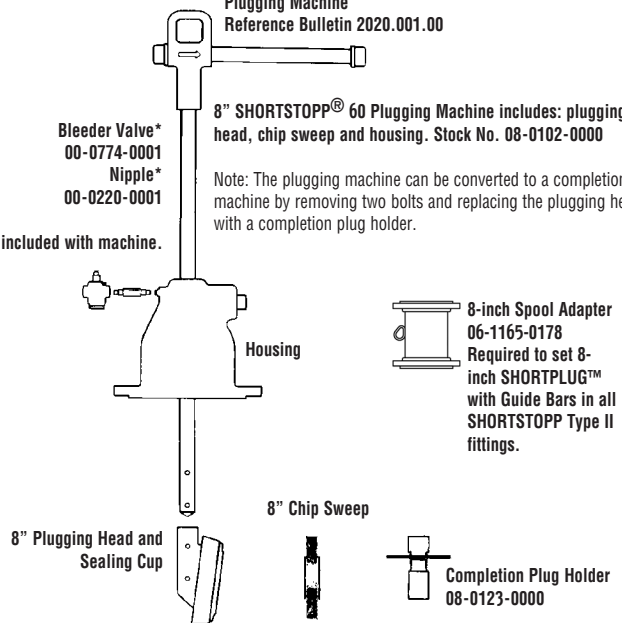

8-inch Spool Adapter  
06-1165-0178  
Required to set 8-inch SHORTPLUG™ with Guide Bars in all SHORTSTOPP Type II fittings.

8" Chip Sweep



Completion Plug Holder  
08-0123-0000

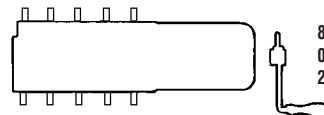

8" SHORTCUTT® Valve  
09-0042-0000  
275 PSI

Valve-to-Fitting Adapter  
06-5724-0003

Optional\*\*

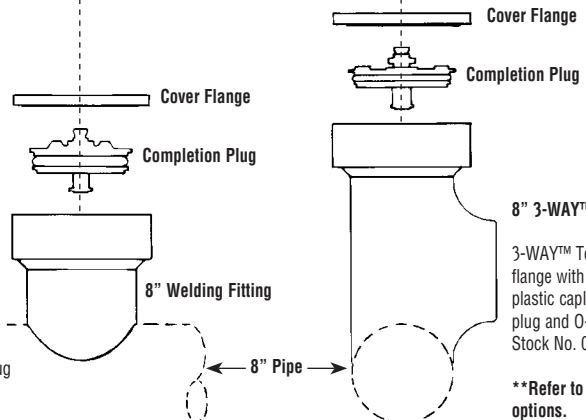

Fitting (includes cover flange with bolts, gasket and plastic caplugs, completion plug and O-ring) Stock No. 06-7215-0000

8" 3-WAY™ Tee

3-WAY™ Tee (includes cover flange with bolts, gasket and plastic caplugs, completion plug and O-ring) Stock No. 06-7220-0000

\*\*Refer to back for fitting options.



T.D. Williamson, Inc.

Data Sheet No. **SS60-8**

# Fittings

## Tapping and **SHORTSTOPP®** 60 Plugging Machine 8" Gas Main

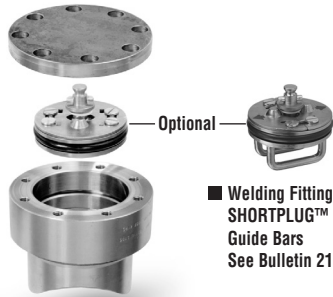

■ **Welding Fitting and SHORTPLUG™ with Guide Bars**  
See Bulletin 2100.013

■ **Welding Fitting**  
See Bulletin 2100.003

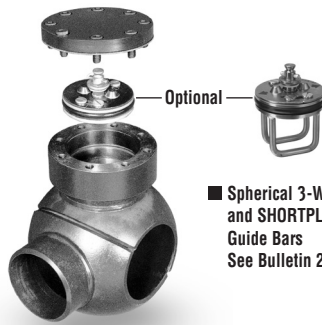

■ **Spherical 3-WAY™ Tee and SHORTPLUG™ with Guide Bars**  
See Bulletin 2100.014

■ **Spherical 3-WAY™ Tee**  
See Bulletin 2100.007

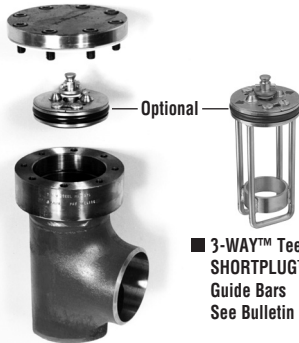

■ **3-WAY™ Tee and SHORTPLUG™ with Guide Bars**  
See Bulletin 2100.012

■ **3-WAY™ Tee**  
See Bulletin 2100.002



■ **Mechanical SHORTSLEEVE™ Fitting**  
See Bulletin 2110.001



■ **Branch Type II 3-WAY™ Tee**  
See Bulletin 2100.011



■ **Branch Type II Plugging Fitting**  
See Bulletin 2100.010

■ **Note:** If you already have 8" **SHORTSTOPP®** plugging equipment, the additional accessories shown below are all that are needed to plug 6" mains (plus Welding Fittings).

 **6" x 8" Valve-to-Fitting Adapter**  
06-5724-0004

 **6" **SHORTSTOPP®** Cutter**  
(nominal)  
05-0330-0006

 **Pilot Drill**  
05-0293-0002

 **Completion Plug Holder**  
08-0122-0000

 **6" Plugging Head with Sealing Cup and Chip Sweep**  
08-0326-0000

 **Cover Flange**

 **Completion Plug**

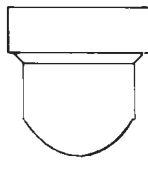
 **Welding Fitting**  
6" Welding Fitting includes:  
cover flange with bolts, gasket  
and plastic caplugs, completion  
plug and O-ring.  
Stock No. 06-5713-0000

■ **Note:** Consult your TDW representative for additional fitting options.