

Tapping and SHORTSTOPP® Plugging Machine

Equipment Needed to Plug a 8" Gas Main to 285 psi



T.D. Williamson, Inc.

Data Sheet No. **SS275-8**

Date: September 2004

Supersedes: January 2003

Tapping

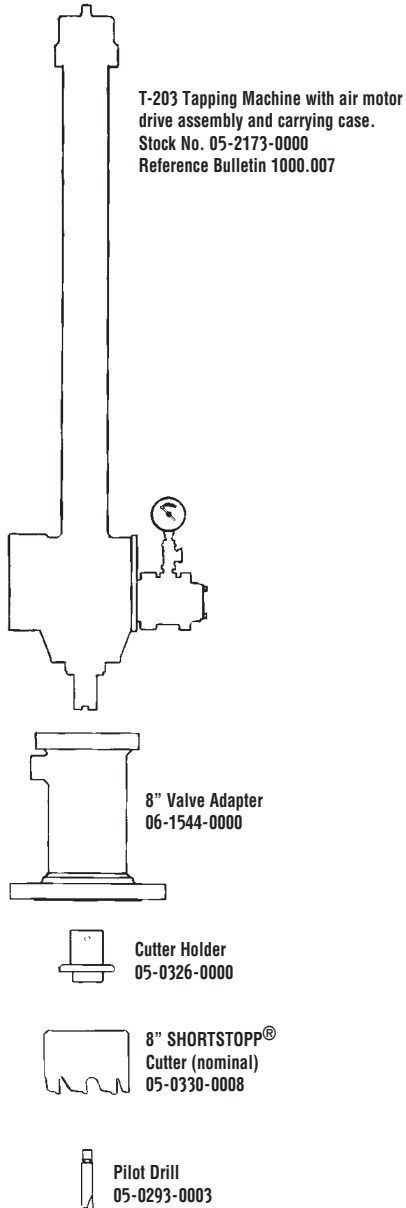

Plugging

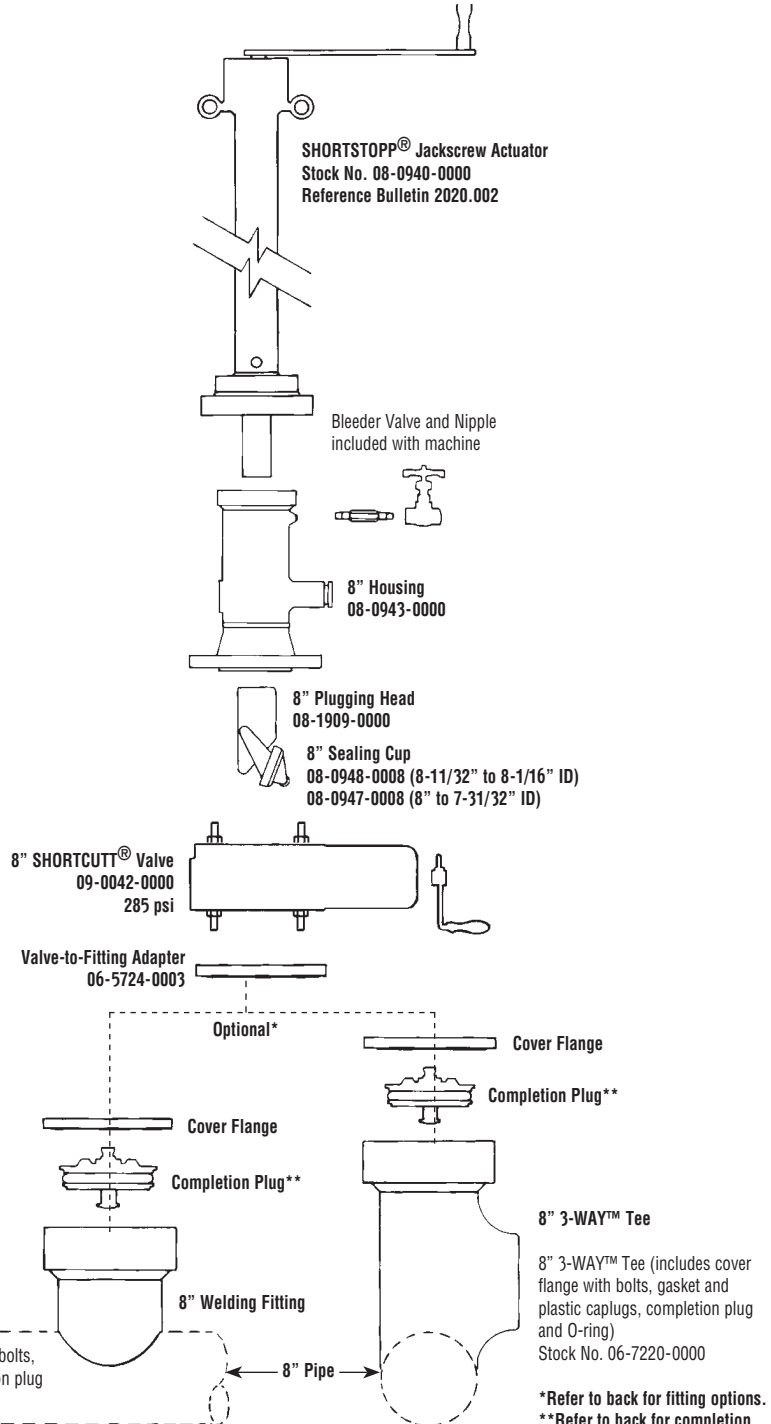



T.D. Williamson, Inc.

Data Sheet No. **SS275-8**

Fittings

Tapping and **SHORTSTOPP**® Plugging Machine

8" Gas Main to 285 psi

Data Sheet No. **SS275-8**

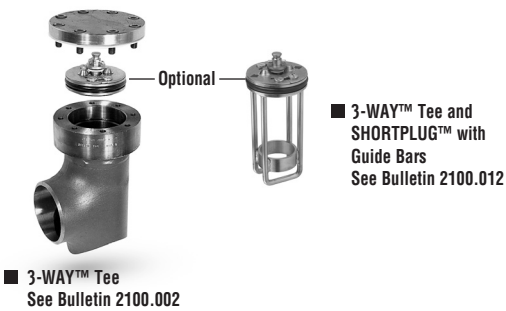
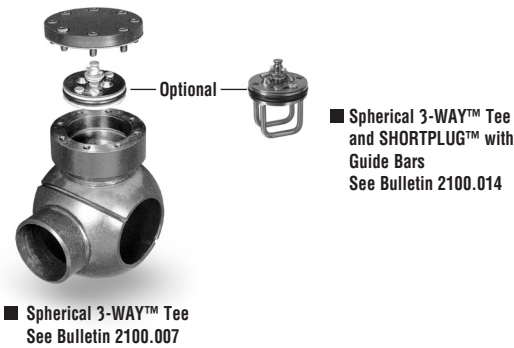
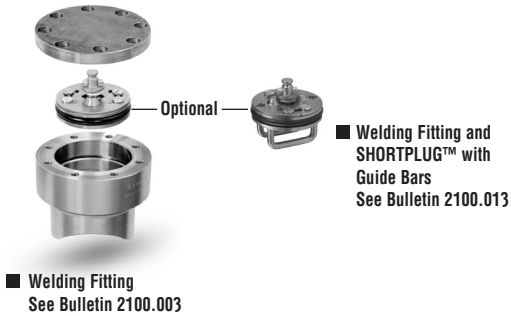

■ Note: Consult your TDW representative for additional fitting options.

Completion

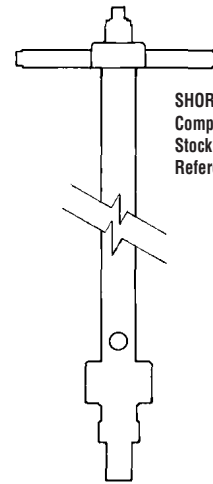

SHORTSTOPP® Plugging/
Completion Machine
Stock No. 07-1034-0000
Reference Bulletin 2020.002.00

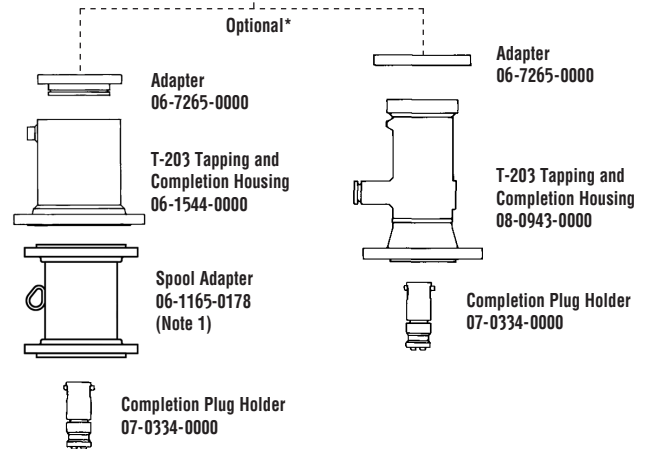

■ Note 1: 8-inch Spool Adapter required to set 8-inch SHORTPLUG™ with Guide Bars in SHORTSTOPP Type II 3-Way™ Tee fittings using the 06-1544-0000 Adapter.