

# Tapping and SHORTSTOPP® Plugging Machine

*Equipment Needed to Plug a 12" Gas Main to 285 psi*



T.D. Williamson, Inc.

Data Sheet No. **SS275-12**

Date: September 2004

Supersedes: January 2003

Data Sheet No. SS275-12

## Tapping

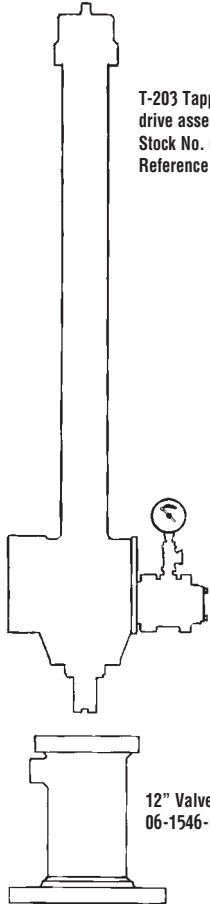

T-203 Tapping Machine with air motor drive assembly and carrying case.  
Stock No. 05-2173-0000  
Reference Bulletin 1000.007

12" Valve Adapter  
06-1546-0000



Cutter Holder  
05-0326-0000



12" SHORTSTOPP®  
Cutter (nominal)  
05-0330-0012



Pilot Drill  
05-0293-0005

## Plugging

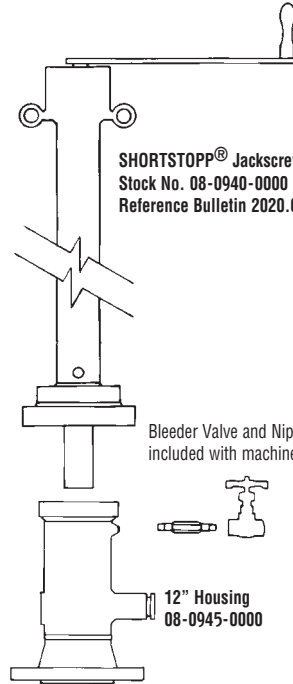

SHORTSTOPP® Jackscrew Actuator  
Stock No. 08-0940-0000  
Reference Bulletin 2020.002

Bleeder Valve and Nipple  
included with machine

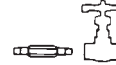

12" Housing  
08-0945-0000



12" Plugging Head  
08-1911-0000

12" Sealing Cup  
08-0947-0012 (12-11/32 to 11-15/16 ID)

12" SHORTCUTT® Valve  
09-0044-0000  
285 psi

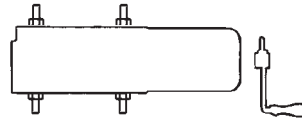

Valve-to-Fitting Adapter  
06-5724-0011

When a 12" SHORTCUTT® Valve is used on a 10" fitting, it will require a 06-5724-0012 Valve-to-Fitting Adapter.

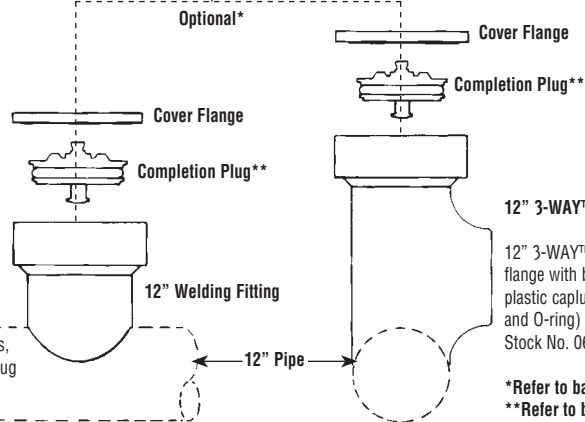

Optional\*

Cover Flange

Completion Plug\*\*

Cover Flange

Completion Plug\*\*

12" Welding Fitting

12" 3-WAY™ Tee

12" 3-WAY™ Tee (includes cover flange with bolts, gasket and plastic caplugs, completion plug and O-ring)  
Stock No. 06-7222-0000

12" Pipe

12" fitting (includes cover flange with bolts, gaskets and plastic caplugs, completion plug and O-ring) Stock No. 06-7217-0000

\*Refer to back for fitting options.  
\*\*Refer to back for completion.



T.D. Williamson, Inc.

Data Sheet No. **SS275-12**

# Fittings

## Tapping and **SHORTSTOPP®** Plugging Machine

### 12" Gas Main to 285 psi

Data Sheet No. **SS275-12**

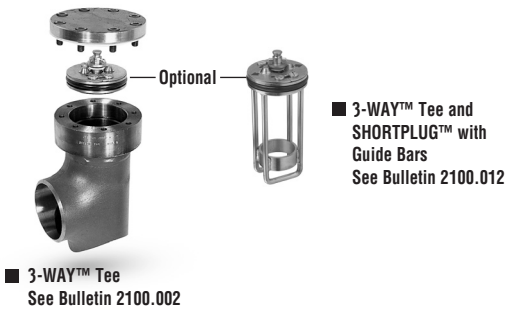
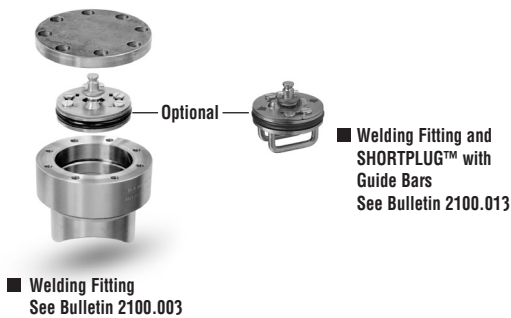

## Completion

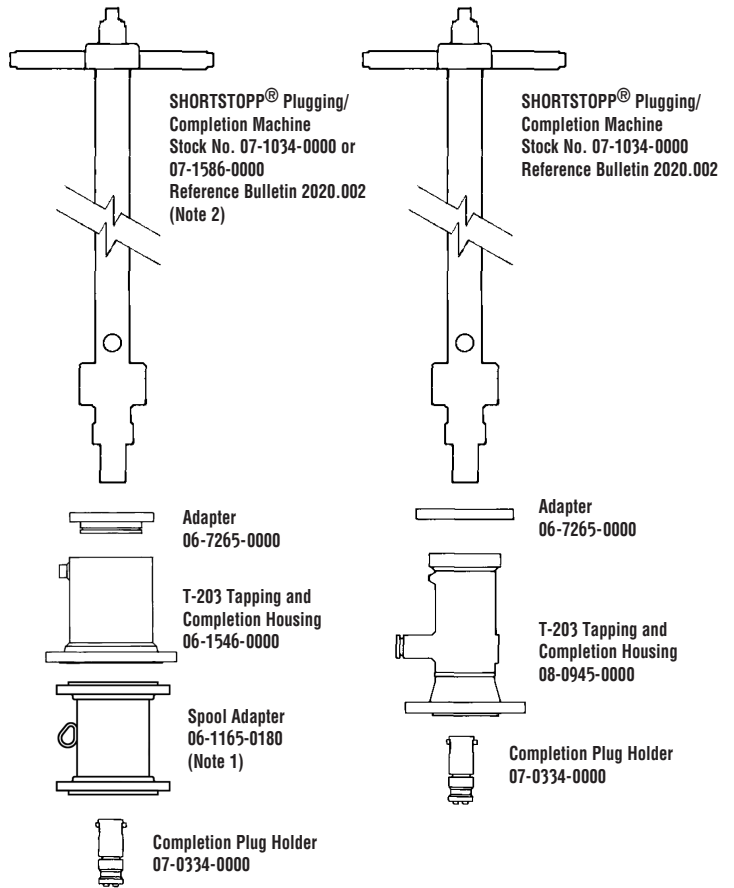

■ Note 1: 12-inch Spool Adapter required to set 12-inch SHORTPLUG™ with Guide Bars in SHORTSTOPP Type II 3-Way™ Tee fittings using the 06-1546-0000 Adapter and 07-1586-0000 Completion Machine

Note 2: The 07-1586-0000 Completion Machine with 48" travel is required to set 12" SHORTPLUG™ with Guide Bars in SHORTSTOPP Type II 3-Way™ Tee fittings using the 06-1546-0000 Adapter.

■ Note: Consult your TDW representative for additional fitting options.