



# SHORTSTOPP® 300D Split Tees and SHORTPLUG™ with Guide Bar

Sizes: 4-to 12-inch



T.D. Williamson

Bulletin No: 2100.015.04

Version: 01.2023

Supersedes: 2100.015.03 (01.2011)

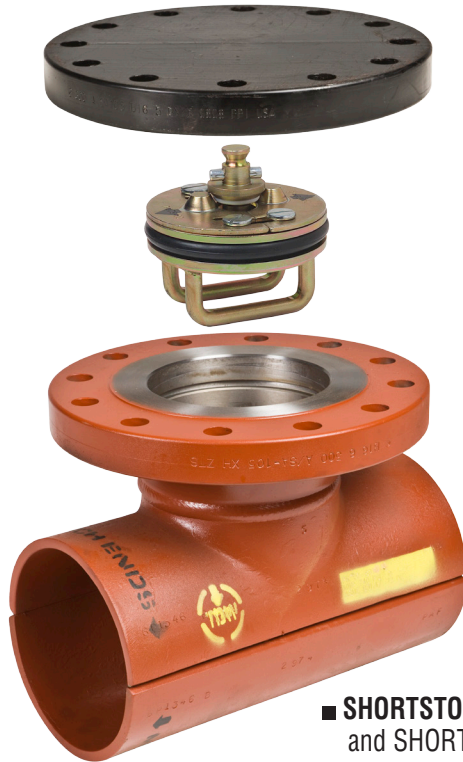

■ **SHORTSTOPP® 300D Split Tee  
and SHORTPLUG™ with Guide Bars**

## Description

The SHORTSTOPP® 300D Fitting and SHORTPLUG™ with Guide Bars is an extruded-style split tee. The fitting is furnished with a flange that is drilled, faced, and pressure rated to match ASME Class 300 flanges. It is used with TDW plugging machines to temporarily plug the line for maintenance or repair without shutdown. The flange is machined to accept SHORTPLUGS with Guide Bars.

## Features

Quality control measures include inspection to ensure a proper fit on the pipeline, flange alignment verification, and radiographic weld inspection\* to API Standard 1104.

The maximum operating pressure of the SHORTSTOPP 300D Fitting is 740 psi (51 bar) at 100°F (38°C). The maximum operating temperature of the SHORTSTOPP 300D Fitting is 180°F (82°C) at 675 psi (47 bar) per ASME B31.4. See chart on page 2 for MAOP per ASME B31.8.

All fittings are stamped with a code number for material identification, and a painted band ensures easy alignment in the field. Material certificates are available.

The 4-inch and larger fittings are complete with blind flange, studs, nuts, gasket, O-ring, and SHORTPLUG with Guide Bars.

\* 100 percent ultrasonic examination performed at TDW's Nivelles, Belgium plant.

## ■ Typical Tapping Setup

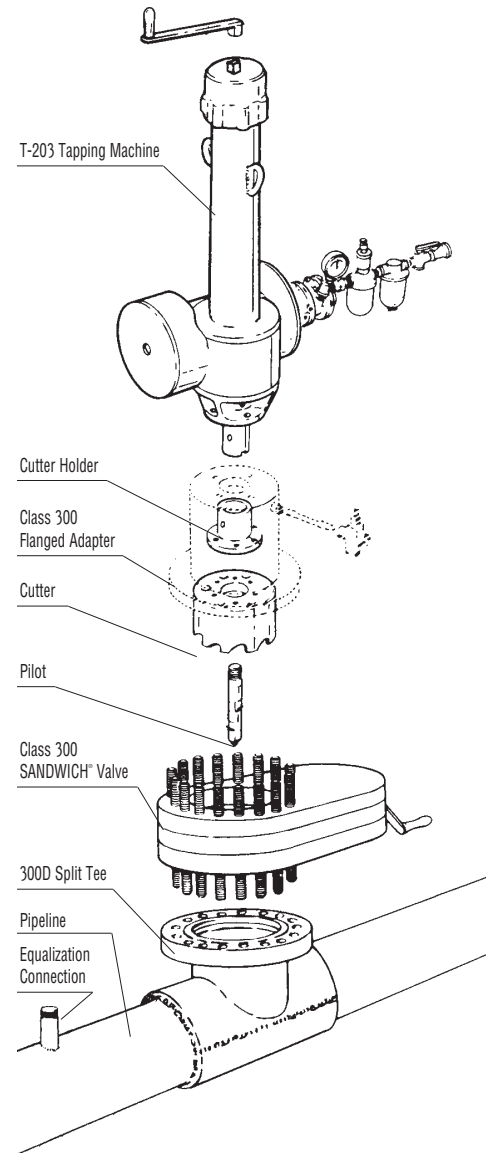

**Maximum Pressure: 740 psig @ 100°F  
Maximum Temperature: 180°F @ 675 psig**



# SHORTSTOPP® 300D Split Tees and SHORTPLUG™ with Guide Bars - .5 Design Factor

## 300D Split Tees Class 300 and SHORTPLUGS with Guide Bars

Maximum allowable operating pressure (in PSI) per ASME B31.8 at -20 to +100° F

Size Inches	DN	Weight		Design Factor				Part Number
		Lbs.	Kg.	0.72	0.6	0.5	0.4	
4	100	80	36	740	740	740	740	26-2427-0004-00
6	150	160	73	740	740	740	605	26-2427-0006-00
8	200	240	109	740	740	740	640	26-2427-0008-00
10	250	390	177	740	740	740	605	26-2427-0010-00
12	300	580	264	740	740	740	605	26-2427-0012-00

The above fittings are complete with cap or blind flange, studs, nuts, gasket, O-ring and SHORTPLUG with Guide Bars.

### Dimensions

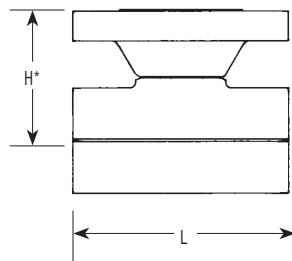

Size		L		H*	
Inches	DN	Inches	mm	Inches	mm
4	100	10.75	273	6.22	158
6	150	14.00	356	7.91	201
8	200	16.50	419	9.47	240
10	250	20.00	508	11.03	280
12	300	22.00	559	12.72	323

\*Height of fitting does not include blind flange and gasket.

### Spare O-Rings

Size		
Inches	DN	Part Number
4	100	00-1250-0001
6	150	00-1250-0002
8	200	00-1250-0003
10	250	00-1250-0004
12	300	00-1250-0005

### SHORTPLUGS with Guide Bars for 300D Split Tees

Size			Weight	
Inches	DN	Part Number	Lbs.	Kg.
4	100	07-1887-0004-00	5	2
6	150	07-1887-0006-00	11	5
8	200	07-1887-0008-00	20	9
10	250	07-1887-0010-00	31	14
12	300	07-0887-0012-00	52	24



# SHORTSTOPP® 300D Split Tees and SHORTPLUG™ with Guide Bars

4-inch Spool Adapter, 06-1165-0181-00 required  
to set the SHORTPLUG® with Guide Bar

Equipment	Housing	Required
SHORTSTOPP® 500	06-7370-0001	Yes
SHORTSTOPP® 500	08-2143-0000	No
SHORTSTOPP® 500	08-2148-0000	No

6-inch Spool Adapter, 06-1165-0182-00 required  
to set the SHORTPLUG® with Guide Bar

Equipment	Housing	Required
SHORTSTOPP® 500	06-7371-0000	No
SHORTSTOPP® 500	08-2144-0000	No

8-inch Spool Adapter, 06-1165-0183-00 required  
to set the SHORTPLUG® with Guide Bar

Equipment	Housing	Required
SHORTSTOPP® 500	06-7372-0000	No
SHORTSTOPP® 500	08-2145-0000	No

10-inch Spool Adapter, 06-1165-0184-00 required  
to set the SHORTPLUG® with Guide Bar

Equipment	Housing	Required
SHORTSTOPP® 500	06-7373-0000	Yes*
SHORTSTOPP® 500	08-2146-0000	No

\* To set the SHORTPLUG™ with Guide Bars with this housing, the 07-1586-0000 completion machine with 48-inch travel is required.

12-inch Spool Adapter, 06-1165-0185-00 required  
to set the SHORTPLUG® with Guide Bar

Equipment	Housing	Required
SHORTSTOPP® 500	06-7374-0000	No
SHORTSTOPP® 500	08-2147-0000	No



**T.D. Williamson**

2100.015 - pg.4