

# 300D Spherical 3-WAY™ Tee



T.D. Williamson

For **SHORTSTOPP®** Plugging Machines

Sizes: 2- to 12-inch

Bulletin No: **2100.008.05**

Version: 12.2022

Supersedes: 2100.008.04 (04.2010)



■ **SHORTSTOPP® 300D**  
**Spherical 3-WAY™ Tee**  
Sizes 2- and 3-inch



■ **SHORTSTOPP® 300D**  
**Spherical 3-WAY™ Tee**  
Sizes 4- to 12-inch

## Description

The **SHORTSTOPP® 300D Spherical 3-WAY™ Tee**, 4" and larger, is furnished with a flange, drilled, faced and pressure-rated to match ASME Class 300 flanges. They are used with TDW plugging machines to temporarily plug the line, without shutdown, while installing a permanent bypass. The bottom half of the fitting can be rotated for a side or a bottom outlet. The flange is machined to accept 300D Completion Plugs.

Quality control measures include inspection to ensure a proper fit on the pipeline, flange alignment verification, and radiographic weld inspection\* to API Standard 1104.

\*100% ultrasonic examination performed at TDW's Nivelles, Belgium location.

## Features

All fittings are stamped with a code number for material identification. Material certificates are available.

The 4" and larger fitting is complete with blind flange, studs, nuts, gasket, O-ring, and completion plug. The 2" and 3" sizes are furnished with a threaded cap, completion plug, and O-ring. The bottom half of the tee can be turned for either a side or bottom outlet. The tee can also be installed horizontally.

With plugging equipment removed, the maximum pressure is 740 psig (49 bar) at 100°F (38° C). The maximum operating temperature is 180°F (82°C) at 675 psig (45 bar) per ASME B31.4. See charts on page 2 for MAOP per ASME B31.8.

## Typical Applications

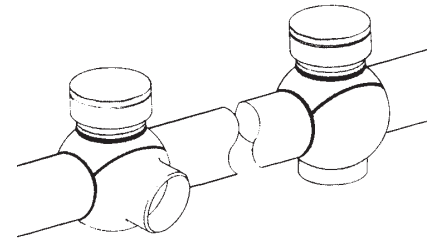

The bottom half of the tee can be turned for either a side or bottom outlet. The tee can also be installed horizontally.

\*Use of **SHORTSTOPP® 275** Plugging Machines is not recommended in bottom outlet configuration.

Class 300 SANDWICH® Valve

Branch

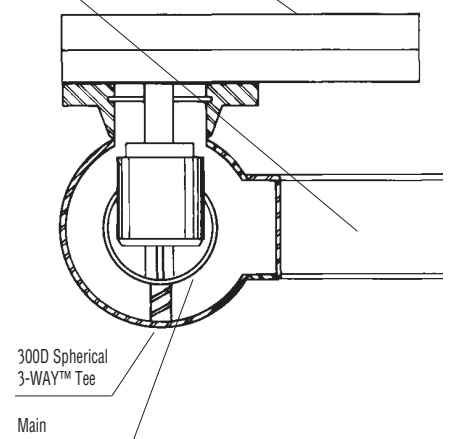

300D Spherical 3-WAY™ Tee

Main

The side outlet plunger can be installed on the control bar of either the **SHORTSTOPP®** Plugging/Completion Machine or the **SHORTSTOPP®** Jackscrew Actuator, and is used on the Spherical 3-WAY™ Tee to plug the tapped hole in the main line. This stops flow into the side outlet, permitting maintenance work on the branch connection.

Maximum working pressure is 275psi for the side outlet plunger.

# SHORTSTOPP 3-WAY Tee 300D Spherical - 0.72 Design Factor



■ 6- to 12-inch

## 300D Spherical 3-WAY Tee Class 300 - 0.72 Design Factor

Maximum Allowable Operating Pressure in PSI, Per ASME B31.8 at -20 to +100° F

Size Inches	DN	Design Factor				Part Number	Weight	
		0.72	0.60	0.50	0.40		Lbs.	Kg.
6	150	740	740	659	527	06-7378-0000	156	70.8
8	200	740	684	570	456	06-7379-0000	248	112.5
10	250	740	690	575	460	26-1141-0000	364	165.1
12	300	740	630	525	420	12333539	502	227.7

The above fittings are complete with cap or blind flange, studs, nuts, gasket, O-ring, and plug.

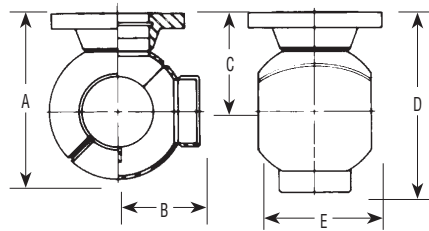

6" (150 mm), 8" (200 mm), 10" (250 mm) and 12" (300 mm)

## Dimensions

Size		A		B		C		D		E	
Inches	DN	Inches	mm	Inches	mm	Inches	mm	Inches	mm	Inches	mm
6	150	15.63	397	7.75	197	9.25	235	17.00	432	10.50	267
8	200	16.88	429	8.31	211	9.88	251	18.19	462	10.56	268
10	250	20.84	529	10.41	264	11.84	301	22.25	565	13.88	352
12	300	22.84	580	11.28	287	12.84	326	24.13	613	14.81	376

## Spare O-Rings

Size		Part Number
Inches	DN	
6	150	00-1250-0002
8	200	00-1250-0003
10	250	00-1250-0004
12	300	00-1250-0005

## 300D Completion Plugs\* Class 300

Size		Part Number	Weight	
Inches	DN		Lbs.	Kg.
6	150	07-1027-0000	10	5
8	200	07-1028-0000	20	9
10	250	07-1029-0000	31	14
12	300	07-1030-0000	44	20

\*Plug setting pressure limited to pressure rating of completion machine.



# SHORTSTOPP 3-WAY Tee 300D Spherical - 0.50 Design Factor



■ 2- & 3-inch

■ 4- through 12-inch

## 300D Spherical 3-WAY Tee Class 300 - 0.50 Design Factor

Maximum Allowable Operating Pressure in PSI, Per ASME B31.8 at -20 to +100° F

Size	Weight	Design Factor				Part Number		
		0.72	0.60	0.50	0.40			
Inches	DN	Lbs.	Kg.					
2	50	17	8	740	740	740	740	26-0935-0000-00
3	80	23	10	740	740	740	740	26-0936-0000-00
4	100	80	36	740	740	740	740	26-0937-0000-00
6	150	160	73	740	740	740	605	26-2366-0000-SF
8	200	260	118	740	740	740	595	26-2367-0000-SF
10	250	380	173	740	740	740	605	26-2368-0000-SF
12	300	870	395	740	740	740	605	26-2369-0000-SF

SF: 00 is for standard weight pipe, 01 is for thin-wall pipe.

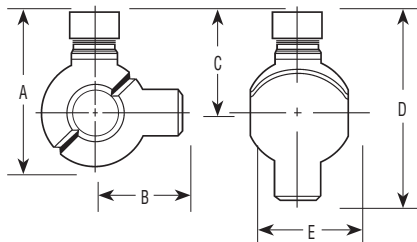

Sizes 2" (50 mm) and 3" (80 mm)

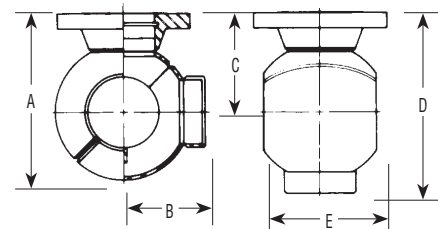

Sizes 4" (100 mm), 6" (150 mm), 8" (200 mm), 10" (250 mm) and 12" (300 mm)

## Dimensions

Size		A		B		C		D		E	
Inches	DN	Inches	mm	Inches	mm	Inches	mm	Inches	mm	Inches	mm
2	50	10.47	266	4.75	121	7.16	182	11.71	297	5.84	148
3	80	13.38	340	5.63	143	9.06	230	14.69	373	7.53	191
4	100	11.28	287	5.41	137	6.97	177	12.38	314	6.91	175
6	150	15.63	397	7.72	196	9.25	235	16.97	431	10.28	261
8	200	19.05	484	9.50	241	11.05	281	20.55	522	12.80	325
10	250	23.06	586	11.62	295	13.06	332	24.68	627	16.03	407
12	300	27.20	691	13.70	348	15.20	386	28.90	734	19.34	491

## Spare O-Rings

Size		Part Number
Inches	DN	
2	50	00-0117-0010
3	80	00-0117-0013
4	100	00-1250-0001
6	150	00-1250-0002
8	200	00-1250-0003
10	250	00-1250-0004
12	300	00-1250-0005

## 300D Completion Plugs\* Class 300

Size		Part Number	Weight	
Inches	DN		Lbs.	Kg.
2	50	07-1745-0000-00	1	1
3	80	07-1746-0000-00	2	1
4	100	07-0351-0000-00	3	1
6	150	07-1027-0000-00	10	5
8	200	07-1853-0000-00	20	9
10	250	07-1854-0000-00	31	14
12	300	07-1855-0000-00	44	20

\*Plug setting pressure limited to pressure rating of completion machine.



T.D. Williamson

2100.008 - pg.4