



OptionAll™ Cleaning Pigs

Sizes: 4- to 14-inch



T.D. Williamson

Bulletin No: **3030.003.05**

Date: 10.2021

Supersedes: 3030.003.04 (01.2007)



■ OptionAll™ Cleaning Pigs

Description

TDW's OptionAll™ Cleaning Pigs can be assembled into several configurations. TDW has assembled four standard configurations to meet most applications.

Due to the unique design of the OptionAll Pig, customization is quickly accomplished with simple hand tools to achieve the best option for your pigging application. With the OptionAll Pig, you truly have an option.

Features

The OptionAll Cleaning Pig features TDW's Formula SI polyurethane which is designed to provide superior abrasion resistance. This new polyurethane means more miles and more runs at less cost.

- Non-wearing components are constructed of Ultra High Molecular Weight (UHMW) polyethylene to protect internal pipe and valve surfaces.

- Recessed steel bolt and locknut construction is designed to prevent breakup of the pig in the pipeline.
- Low-cost, long-wearing design provides users with the option to dispose of or rebuild the pig.
- Large-diameter conical cups are designed to seal in the thinnest of pipe walls.
- Lightweight design can be handled by one person and reduces shipping costs.
- All OptionAll Pigs are supplied with large eye rings, which are designed to allow the pig to be easily hooked and removed from the receiving trap.

Options

T.D. Williamson is committed to providing you with the exact product to assist you in meeting the needs of your individual applications.

The OptionAll Cleaning Pig is designed to fit many needs, using standard TDW components. Special configurations can be made to meet virtually any customer specification. Some of the possible special configurations are listed below:

- Pigs can be made shorter or longer.
- Pigs can have more or fewer cups and/or discs in any arrangement.
- Pig bodies can be provided with cavities to house transmitters for tracking or locating purposes.
- Pigs cups and/or discs can be provided with bypass holes for maximum cleaning effectiveness.
- Cups and/or discs can be modified for very heavy wall pipe.
- Aluminum, slotted aluminum or steel gauging flanges can be provided.
- Brushes with stainless steel bristles.
- Pig cups and/or discs can be provided in Neoprene, Buna-N or Viton.

OptionAll™ Cleaning Pigs



2C-1BR Configuration

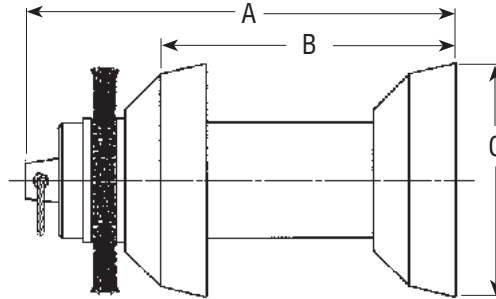

Size	Weight	Part Number	A	B	C
Inch (mm)	Lbs (kg)		Inch (mm)	Inch (mm)	Inch (mm)
4 (100)	3.0 (1.3)	02-2589-0004	7.75 (197)	5.0 (127)	4.50 (114)
6 (150)	7.5 (3.4)	02-2589-0006	12.12 (308)	8.31 (211)	6.62 (168)
8 (200)	13.5 (6.1)	02-2589-0008	15.38 (390)	10.78 (274)	8.62 (219)
10 (250)	26.0 (11.8)	02-2589-0010	20.69 (525)	15.78 (401)	10.6 (270)
12 (300)	32.0 (14.5)	02-2589-0012	22.12 (562)	15.98 (406)	12.6 (321)
14 (350)	36.50 (16.5)	02-2589-0014	22.81 (579)	16.12 (409)	14.0 (356)

2C-1BR Configurations are designed to traverse 1.5 DR bends.

4C-2BR Configuration

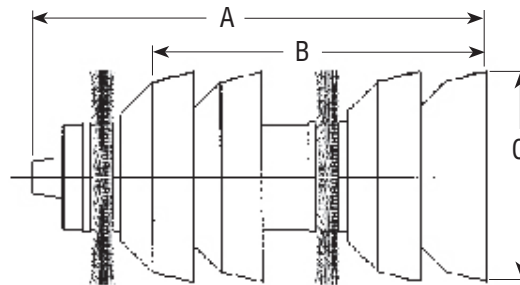

Size	Weight	Part Number	A	B	C
Inch (mm)	Lbs (kg)		Inch (mm)	Inch (mm)	Inch (mm)
4 (100)	2.75 (1.2)	02-2641-0004	10.75 (273)	8.00 (203)	4.50 (114)
6 (150)	10.39 (4.7)	02-2641-0006	14.31 (363)	10.5 (267)	6.62 (168)
8 (200)	19.73 (9.0)	02-2641-0008	20.68 (525)	16.09 (409)	8.62 (219)
10 (250)	36.72 (16.7)	02-2641-0010	23.00 (584)	18.09 (459)	10.62 (270)
12 (300)	49.50 (22.5)	02-2641-0012	28.44 (722)	22.28 (566)	12.62 (321)
14 (350)	56.63 (25.7)	02-2641-0014	29.12 (740)	22.43 (570)	14.00 (356)

4C-2BR Configurations are designed to traverse 3.0 DR bends.

OptionAll™ Cleaning Pigs



DCDC-2BR Configuration

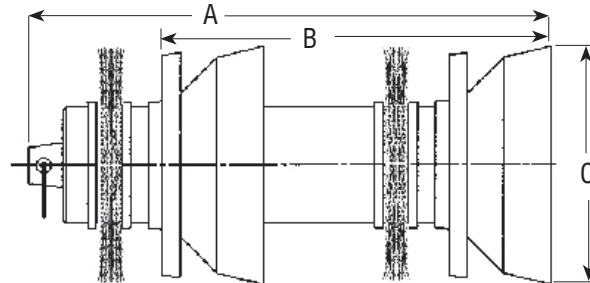

Size	Weight		A	B	C
Inch (mm)	Lbs (kg)	Part Number	Inch (mm)	Inch (mm)	Inch (mm)
4 (100)	2.75 (1.2)	02-2592-0004	8.50 (216)	6.00 (152)	4.50 (114)
6 (150)	10.39 (4.7)	02-2592-0006	14.44 (367)	10.75 (273)	6.62 (168)
8 (200)	19.73 (9.0)	02-2592-0008	19.56 (497)	15.62 (397)	8.62 (219)
10 (250)	36.72 (16.7)	02-2592-0010	21.38 (543)	17.31 (490)	10.62 (270)
12 (300)	49.50 (22.5)	02-2592-0012	26.56 (675)	22.25 (565)	12.62 (321)
14 (350)	56.63 (25.7)	02-2592-0014	27.25 (692)	22.94 (583)	14.00 (356)

DCDC-2BR Configurations are designed to traverse 3.0 DR bends.

4D-2BR Configuration

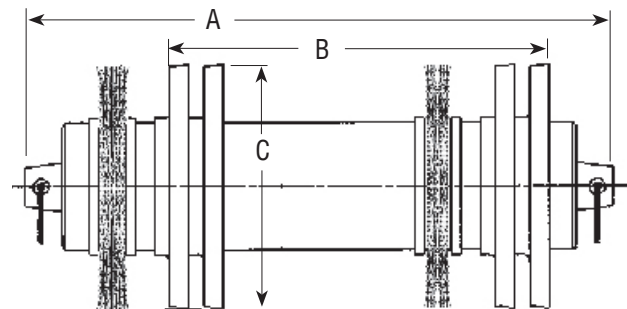

Size	Weight		A	B	C
Inch (mm)	Lbs (kg)	Part Number	Inch (mm)	Inch (mm)	Inch (mm)
4 (100)	2.75 (1.3)	02-2591-0004	10.25 (260)	6.50 (165)	4.31 (109)
6 (150)	9.75 (4.4)	02-2591-0006	15.00 (381)	9.68 (246)	6.25 (159)
8 (200)	17.83 (8.1)	02-2591-0008	19.62 (498)	14.06 (357)	8.38 (213)
10 (250)	34.21 (15.5)	02-2591-0010	21.38 (543)	15.56 (395)	10.50 (267)
12 (300)	40.80 (18.5)	02-2591-0012	25.38 (644)	19.31 (490)	12.50 (318)
14 (350)	47.75 (21.7)	02-2591-0014	25.38 (644)	19.31 (490)	13.75 (349)

4D-2BR Configurations are designed to traverse 3.0 DR bends.

OptionAll™ Cleaning Pigs

Replacement Cups, Discs and Brushes

Size Inch (mm)	Cup Weight Lbs (kg)	Cup Part Number	Disc Weight Lbs (kg)	Disc Part Number	Brush Weight Lbs (kg)	Brush Part Number
4 (100)	0.4 (0.2)	00-4120-0004-03	0.2 (0.1)	00-1702-0014-00	0.5 (0.25)	02-2605-0004-00
6 (150)	1.2 (0.5)	00-4120-0006-03	0.8 (0.4)	00-1702-0001-00	0.5 (0.25)	00-7078-0006-00
8 (200)	2.5 (1.1)	00-4120-0008-03	1.5 (0.7)	00-1702-0002-00	1.0 (0.5)	00-7078-0008-00
10 (250)	3.7 (1.7)	00-4120-0010-03	2.4 (1.1)	00-1702-0003-00	2.0 (1.0)	00-7078-0010-00
12 (300)	6.0 (2.7)	00-4120-0012-03	3.4 (1.5)	00-1702-0004-00	3.0 (1.5)	00-7078-0012-00
14 (350)	8.0 (3.6)	00-4120-0014-03	4.0 (1.8)	00-1702-0010-00	3.75 (1.7)	00-7078-0014-00

Bypass Hole Recommendations*

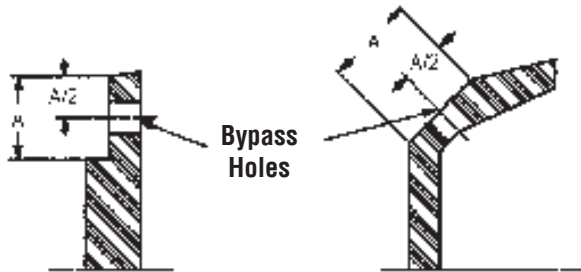

Size		No. of Eq Sp Holes	Diameter of Holes	
Inch	mm		Inch	mm
4"	100	4	.37"	10
6"	150	6	.50"	13
8"	200	8	.50"	13
10"	250	8	.63"	16
12"	300	8	.75"	19
14"	350	8	.75"	19

* for approximately 3% bypass

Cups and discs with bypass holes are available from the factory.

Wood boring bits are recommended for drilling holes in urethane.

OptionAll™ Batching Pigs

Sizes: 4- to 14-inch



T.D. Williamson

Bulletin No: 3030.004.06

Version: 10.2021

Supersedes: 3030.004.05 (02.2016)



Options

T.D. Williamson is committed to providing you with the exact product to assist you in meeting the needs of your individual applications.

The OptionAll Batching Pig is designed to fit many needs, using standard TDW components. Special configurations can be made to meet virtually any customer specification. Some of the possible special configurations are listed below:

- Pigs can be made shorter or longer.
- Pigs can have more or fewer cups and/or discs in any arrangement.
- Pig bodies can be provided with cavities to house transmitters for tracking or locating purposes.
- Pig cups and/or discs can be provided with bypass holes for maximum cleaning effectiveness.
- Cups and/or discs can be modified for extra heavy wall pipe.
- Aluminum, slotted aluminum or steel gauging flanges can be provided.
- Pig cups and/or discs can be provided in Neoprene, Buna-N, or Viton.

Description

TDW's OptionAll™ Batching Pigs can be assembled into several configurations. TDW has assembled seven standard configurations to meet most applications. Due to the unique design of the OptionAll Pig, customization is quickly accomplished with simple hand tools to achieve the best option for your pigging application.

The OptionAll Batching Pig is designed for light cleaning, line filling and dewatering, batch separation and liquid removal. The replaceable cups and discs make special configurations easy and its low cost gives users the option to dispose of or rebuild the pig after hard use.

Features

The OptionAll Batching Pig features TDW's Formula SI polyurethane which is designed to provide superior abrasion resistance. This new polyurethane means more miles and more runs at less cost.

- Non-wearing components are constructed of Ultra High Molecular Weight (UHMW) polyethylene to protect internal pipe and valve surfaces.
- Recessed steel bolt and locknut construction is designed to prevent breakup of the pig in the pipeline.
- Low-cost, long-wearing design provides users with the option to dispose of or to rebuild the pig.
- Large-diameter conical cups are designed to seal in the thinnest of pipe walls.
- The OptionAll Pig is designed to traverse 1.5 DR bends (unless otherwise noted), check valves and full-size tees designed for pig passage.
- Lightweight design can be handled by one person and reduces shipping costs.
- All OptionAll Pigs are supplied with large eye rings, which are designed to allow the pig to be easily hooked and removed from the receiving trap.

OptionAll™ Batching Pigs

2C Configuration

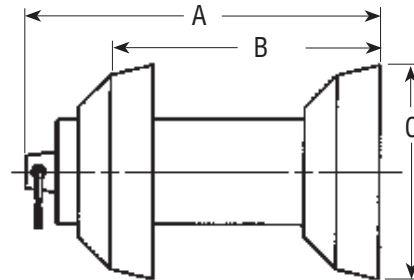

2C configurations are recommended for light cleaning, line filling and dewatering, batch separation, and liquid removal. They are normally used in pipelines up to 50 miles (80 km) in length. (For longer runs, a 3C or 4C configuration would be recommended. For operating pipelines, a 4C or DCDC is recommended.)

Size	Weight		A	B	C
Inch (mm)	Lb. (Kg)	Part Number	Inch (mm)	Inch (mm)	Inch (mm)
4 (100)	2.0 (0.9)	01-1700-0004	8.00 (203)	6.25 (159)	4.50 (114)
6 (150)	5.8 (2.6)	01-1700-0006	12.6 (319)	9.94 (252)	6.62 (168)
8 (200)	12 (5.4)	01-1700-0008	16.9 (430)	13.8 (350)	8.62 (219)
10 (250)	19 (8.6)	01-1700-0010	19.2 (489)	15.8 (401)	10.6 (270)
12 (300)	26 (12)	01-1700-0012	23.9 (608)	19.5 (494)	12.6 (321)
14 (350)	30 (14)	01-1700-0014	24.6 (625)	19.6 (498)	14.0 (356)

3C Configuration

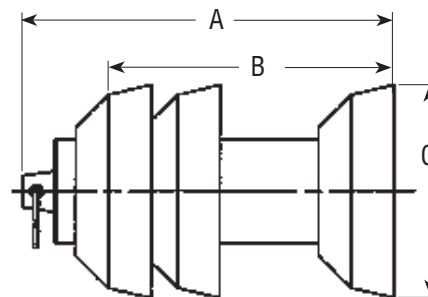

3C configurations are recommended for light cleaning, line filling and dewatering, batch separation and liquid removal. They are normally used in pipelines up to 100 miles (161 km) in length. (For longer runs, a 4C configuration would be recommended. For operating pipelines, a 4C or DCDC configuration is recommended.)

Size	Weight		A	B	C
Inch (mm)	Lb. (Kg)	Part Number	Inch (mm)	Inch (mm)	Inch (mm)
4 (100)	4.8 (2.2)	01-1701-0004	8.38 (213)	6.62 (168)	4.50 (114)
6 (150)	6.5 (2.9)	01-1701-0006	13.1 (332)	10.4 (265)	6.62 (168)
8 (200)	14 (6.4)	01-1701-0008	17.4 (441)	14.2 (361)	8.62 (219)
10 (250)	22 (10)	01-1701-0010	19.7 (500)	16.2 (412)	10.6 (270)
12 (300)	32 (15)	01-1701-0012	24.5 (622)	20.0 (509)	12.6 (321)
14 (350)	38 (17)	01-1701-0014	25.2 (640)	20.2 (513)	14.0 (356)

OptionAll™ Batching Pigs

4C Configuration



4C configurations are recommended for light cleaning, line filling and dewatering, batch separation and liquid removal in pipelines of all lengths.

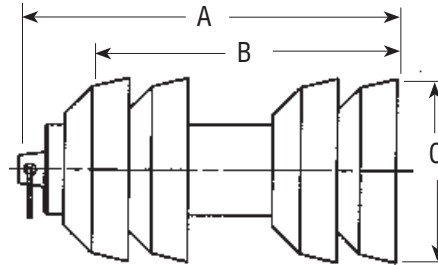

Size	Weight	Part Number	A	B	C
Inch (mm)	Lb. (Kg)		Inch (mm)	Inch (mm)	Inch (mm)
4 (100)	2.7 (1.2)	01-1702-0004	8.75 (222)	7.00 (178)	4.50 (114)
6 (150)	8.0 (3.6)	01-1702-0006	13.6 (344)	10.9 (278)	6.62 (168)
8 (200)	16 (7.3)	01-1702-0008	17.8 (452)	14.7 (372)	8.62 (219)
10 (250)	27 (12)	01-1702-0010	20.1 (511)	16.7 (423)	10.6 (270)
12 (300)	38 (17)	01-1702-0012	25.1 (637)	20.6 (523)	12.6 (321)
14 (350)	46 (21)	01-1702-0014	25.8 (654)	20.8 (527)	14.0 (356)

DCDC Configuration



DCDC configurations are recommended for medium-duty cleaning in crude oil, natural gas and refined products pipelines of all lengths. Discs are effective in removing loose solids and soft paraffin buildups from pipe walls. (A bypass option is recommended if a significant amount of solids is expected.)

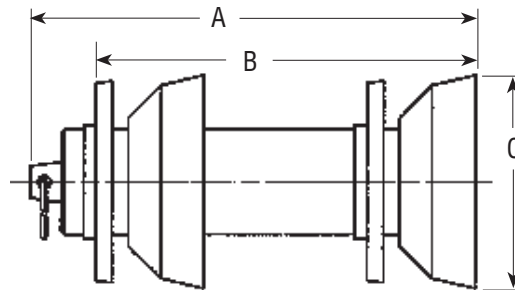

Size	Weight	Part Number	A	B	C
Inch (mm)	Lb. (Kg)		Inch (mm)	Inch (mm)	Inch (mm)
4 (100)	2.2 (1.0)	01-1703-0004	8.75 (222)	7.25 (184)	4.50 (114)
6 (150)	6.9 (3.1)	01-1703-0006	13.7 (348)	11.7 (297)	6.62 (168)
8 (200)	13 (5.9)	01-1703-0008	16.7 (424)	14.7 (373)	8.62 (219)
10 (250)	22 (10)	01-1703-0010	18.5 (470)	16.4 (416)	10.6 (270)
12 (300)	31 (14)	01-1703-0012	23.2 (589)	21.0 (535)	12.6 (321)
14 (350)	36 (16)	01-1703-0014	23.9 (607)	21.8 (552)	14.0 (356)

OptionAll™ Batching Pigs

4D Configuration

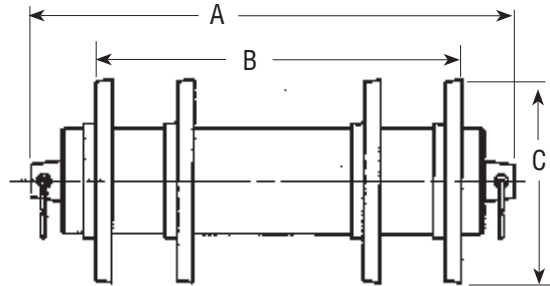
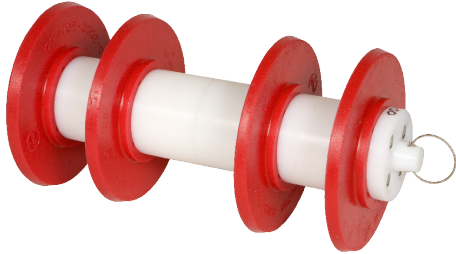

4D configurations are recommended for bi-directional applications in which the pig has to be run in two directions before being removed from the line. They are normally used for line filling-testing-dewatering applications in lines up to 40 miles (65 km) in length.

Size	Weight		A	B	C
Inch (mm)	Lb. (Kg)	Part Number	Inch (mm)	Inch (mm)	Inch (mm)
4 (100)	2.0 (0.9)	01-1705-0004	9.50 (241)	6.75 (171)	4.31 (110)
6 (150)	6.7 (3.0)	01-1705-0006	14.9 (378)	11.2 (286)	6.25 (159)
8 (200)	12 (5.4)	01-1705-0008	18.8 (476)	15.1 (384)	8.38 (213)
10 (250)	22 (10)	01-1705-0010	21.0 (533)	17.1 (435)	10.5 (267)
12 (300)	31 (14)	01-1705-0012	24.5 (622)	20.6 (524)	12.5 (318)
14 (350)	32 (15)	01-1705-0014	24.5 (622)	20.6 (524)	13.8 (349)

6D Configuration

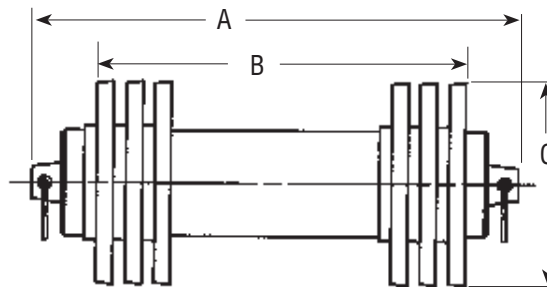

6D configurations are recommended for bi-directional applications in which the pig has to be run in two directions before being removed from the line. They are normally used for line filling-testing-dewatering applications in lines up to 60 miles (97 km) in length.

Size	Weight		A	B	C
Inch (mm)	Lb. (Kg.)	Part Number	Inch (mm)	Inch (mm)	Inch (mm)
4 (100)	2.1 (1.0)	01-1706-0004	9.25 (235)	6.50 (165)	4.31 (110)
6 (150)	7.9 (3.6)	01-1706-0006	15.0 (381)	11.4 (289)	6.25 (159)
8 (200)	15 (6.8)	01-1706-0008	17.5 (444)	13.9 (352)	8.38 (213)
10 (250)	25 (11)	01-1706-0010	21.2 (540)	17.4 (441)	10.5 (267)
12 (300)	36 (16)	01-1706-0012	24.8 (629)	20.9 (530)	12.5 (318)
14 (350)	39 (18)	01-1706-0014	24.8 (629)	20.9 (530)	13.8 (349)

OptionAll™ Batching Pigs

DD Configuration

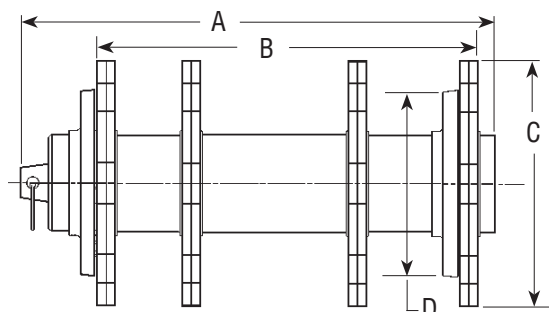
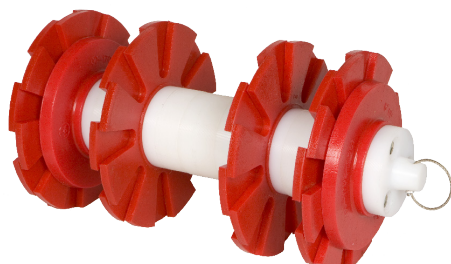

Size	Weight	Part Number	A	B	C	D	Min Bend
Inch (mm)	Lb. (Kg.)		Inch (mm)	Inch (mm)	Inch (mm)	Inch (mm)	Radius (in.)
6x8 (150x200)	10 (4.5)	01-1708-0608	16.00 (406)	12.88 (327)	8.25 (210)	6.25 (159)	1.5 - 8 3.0 - 6
8x10 (150x250)	13.3 (6.0)	01-1708-0810	23.88 (607)	20.62 (505)	10.25 (260)	8.38 (213)	1.5 - 10 3.0 - 8
8x12 (150x300)	14.0 (6.3)	01-1708-0812	23.88 (607)	20.62 (505)	12.25 (311)	8.38 (213)	1.5 - 12 3.0 - 8
10x12 (250x300)	22.5 (10.2)	01-1708-1012	22.00 (559)	18.62 (473)	12.25 (311)	10.50 (267)	1.5 - 12 3.0 - 10
10x14 (250x350)	24.0 (10.8)	01-1708-1014	22.00 (559)	18.62 (473)	13.50 (343)	10.50 (267)	1.5 - 14 3.0 - 10
12x14 (300x350)	26.3 (12.7)	01-1708-1214	22.00 (559)	18.62 (473)	13.50 (343)	12.50 (318)	1.5 - 14 3.0 - 12

Dual diameter configurations are recommended for applications in which the pig has to run in multiple sizes of pipe in one run.

OptionAll™ Batching Pigs

Replacement Cups and Discs

Size Inch (mm)	Cup Weight Lb. (Kg.)	Cup Part Number	Disc Weight Lb. (Kg.)	Disc Part Number
4 (100)	0.4 (0.2)	00-4120-0004-03	0.2 (0.1)	00-1702-0014-00
6 (150)	1.2 (0.5)	00-4120-0006-03	0.8 (0.4)	00-1702-0001-00
8 (200)	2.5 (1.1)	00-4120-0008-03	1.5 (0.7)	00-1702-0002-00
10 (250)	3.7 (1.7)	00-4120-0010-03	2.4 (1.1)	00-1702-0003-00
12 (300)	6.0 (2.7)	00-4120-0012-03	3.4 (1.5)	00-1702-0004-00
14 (350)	8.0 (3.6)	00-4120-0014-03	4.0 (1.8)	00-1702-0010-00

Bypass Hole Recommendations*

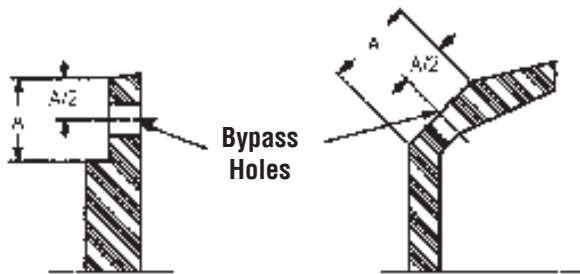

Size	No. of Eql Sp Holes	Diameter of Holes
4 in. (100 mm)	4	.37 in. (10mm)
6 in. (150 mm)	6	.50 in. (13mm)
8 in. (200 mm)	8	.50 in. (13mm)
10 in. (250 mm)	8	.63 in. (16mm)
12 in. (300 mm)	8	.75 in. (19mm)
14 in. (350 mm)	8	.75 in. (19mm)

* for approximately 3% bypass

Cups and discs with bypass holes are available from the factory.

Wood boring bits are recommended for drilling holes in urethane.