



WCK Cleaning Pigs

Sizes: 6- to 14-inch



T.D. Williamson

Bulletin No: **3000.002.04**

Version: 10.2021

Supersedes: 3000.002.03 (05.2010)

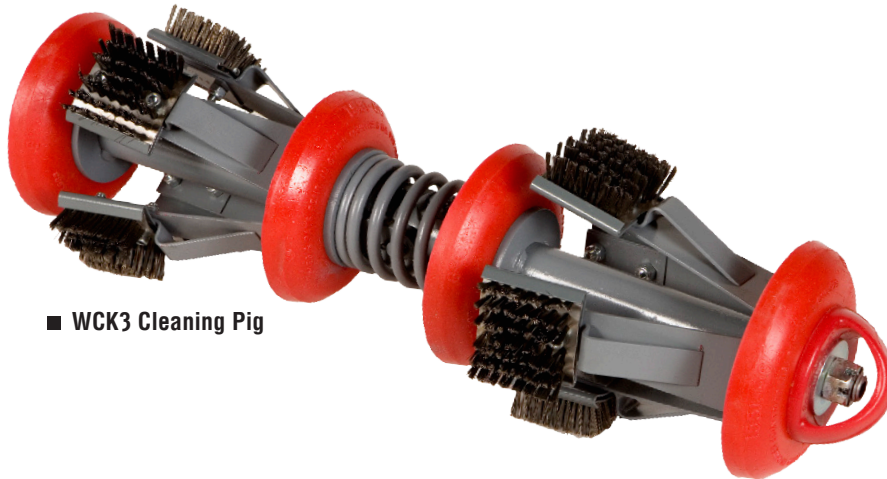

■ WCK3 Cleaning Pig

Description

Contamination buildup increases resistance to flow, which decreases pipeline efficiency. WCK Cleaning Pigs are used to improve and maintain all types of pipelines by removing contaminants and deposits in the pipe. Dual-diameter (DD) WCK Pigs clean multiple sizes of pipe in one run. Both types have tempered steel springs that force the brushes against the pipe and flex inward to avoid obstructions.

WCK Pigs come equipped with tempered steel wire brushes and urethane cups. The dual diameter WCK Pigs for cleaning multiple sizes of pipe are equipped with steel wire brushes and discs. An outlet port at the front end of the WCK Pigs provides fluid bypass to prevent piling of loosened material. For severe deposits, extra bypass holes can be drilled through the cups.

Features

WCK Cleaning Pigs are built with TDW's urethane scraper cups or discs, which are made of liquid-cast urethane, a high-strength, tough elastomer. Advantages of urethane cups and discs include minimum swelling, exceptional resistance to hydrocarbons, lightweight, reduced blistering, and increased abrasion resistance.

WCK-DD Pigs are built with a collapsible urethane disk. Both types of pigs are built with TDW steel wire brushes, made from high-carbon, tempered steel. Cups and discs operate in temperatures ranging from -20°F to 200°F (-29°C to 93°C).

Options

WCK-12 and WCK-3 Pigs are available in sizes 6" (150 mm) to 14" (350 mm). WCK-12DD and WCK-3DD Pigs are available in sizes 6" x 8" (150 mm x 200 mm) to 14" x 16" (350 mm x 400 mm).

WCK Pigs are available with heavy duty type urethane scraper cups. Cups and discs are available in Buna-N, Neoprene and Viton. Urethane plow blades are available in place of wire brushes.

To help you obtain the proper pig for your application, check to see if the selection is capable of traversing your particular pipeline components (bends, valves, tees, etc.).



■ WCK3DD



■ WCK12

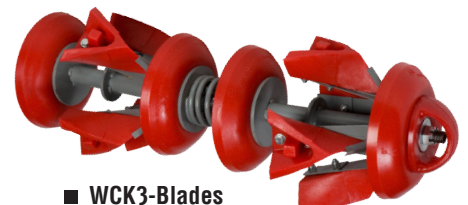

■ WCK3-Blades



WCK Cleaning Pigs

Sizes 6" through 14"

		WCK-12 Pigs			WCK-3 Pigs		
Inches	mm	Wt./Lbs.	Wt./Kg.	Part Number	Wt./Lbs.	Wt./Kg.	Part Number
6	150	25	11	02-1903-0000	33	15	02-1798-0000
8	200	34	15	02-1904-0000	44	20	02-1799-0000
10	250	53	24	02-1905-0000	74	34	02-1900-0000
12	300	76	34	02-1906-0000	109	49	02-1901-0000
14	350	86	39	02-1907-0000	120	54	02-1902-0000

		WCK-12DD Pigs			WCK-3DD Pigs		
6 x 8	150 x 200	37	17	02-1908-0000	44	20	02-1925-0000
8 x 10	200 x 250	43	20	02-1909-0000	65	29	02-1926-0000
8 x 12	200 x 300	46	21	02-1910-0000	70	32	02-1927-0000
10 x 12	250 x 300	75	34	02-1911-0000	110	50	02-1928-0000
10 x 14	250 x 350	78	35	02-1912-0000	121	55	02-1929-0000
12 x 16	300 x 400	86-1/2	39	02-1913-0000	129	59	02-1930-0000
14 x 16	350 x 400	88	49	02-1914-0000	139	63	02-1931-0000

Components

Item	Description	WCK-12	WCK-3	WCK-12DD	WCK-3DD
1	Body	1	2	1	2
3	Flange	1	4	1	4
4	Brush	8	8	16*	16*
5	Holder	8	8	8	8
6	Spacer	2	2	2	2
7	Spring Assembly	2	2	2	2
8	Screw	16	16	32	32
9	Body Nut	2	2	2	2
10	Nose and Rear Bumper	2	2	2	2
11	Spring Liner	8	8	8	8
12	Coupler Spring	--	1	--	1
13	Disc, Slotted	--	--	4	8
14	Urethane Cup	2	4	--	--
15	Bypass Plug	1	1	1	1
16	Coupler Pin	--	2	--	2
17	Coupler Block	--	1	--	1
18	Cotter Pin	--	4	--	4
22	Disc, Solid	--	--	2	4
27	Guide Pin	8	8	8	8
28	Cotter Pin	2	6	2	2
29	ESNA Nut	16	16	32	32
31	Washer	2	2	2	2



WCK Cleaning Pigs

Dimensions

		WCK-12				WCK-3					
		A		L		A		B		L	
Inches	mm	Inches	mm	Inches	mm	Inches	mm	Inches	mm	Inches	mm
6	150	17-15/16	456	22-1/8	562	23-15/16	608	9-7/16	240	28-1/8	714
8	200	20	508	24-5/8	625	27-1/16	687	10-7/8	276	31-11/16	805
10	250	18-3/8	467	24-1/8	613	27-11/16	703	10-1/8	257	33-7/16	849
12	300	19-9/16	497	25-1/4	641	28-13/16	732	10-11/16	271	34-5/8	879
14	350	19-9/16	497	25-1/4	641	28-1/4	718	10-13/16	275	33-15/16	

		WCK-12DD				WCK-3DD			
		A		L		A		L	
Inches	mm	Inches	mm	Inches	mm	Inches	mm	Inches	mm
6 x 8	150 x 200	20-1/4	514	23-1/4	591	28-1/4	718	32-1/4	819
8 x 10	200 x 250	25-3/8	645	30-3/4	781	35-1/4	895	38-3/4	984
8 x 12	200 x 300	25-3/8	645	30-3/4	781	35-1/4	895	38-3/4	984
10 x 12	250 x 300	26-1/8	664	32-3/4	832	37-1/4	946	42-1/4	1073
10 x 14	250 x 350	26-1/8	664	32-3/4	832	37-1/4	946	42-1/4	1073
12 x 16	300 x 400	27-5/8	702	34-1/4	870	40-1/4	1022	45-1/4	1149
14 x 16	350 x 400	27-5/8	702	34-1/4	870	39-1/4	997	45-1/4	1149

Replacement Parts

WCK-12, WCK-3, WCK-12DD, and WCK-3DD Pigs

				Spring Liner		Guide Fins	
Inches	mm	Inches	mm	Part Number	Wt./Lbs.	Wt./Kg.	Part Number
6	150	6 x 8	150 x 200	00-0054-0001	1/8	0.06	00-0053-0001
8	200	8 x 10	200 x 250	00-0054-0001	1/8	0.06	00-0053-0001
		8 x 12	200 x 300	00-0054-0001	1/8	0.06	00-0053-0001
10	250	10 x 12	250 x 300	00-0054-0002	1/8	0.06	00-0053-0001
		10 x 14	250 x 350	00-0054-0002	1/8	0.06	00-0053-0001
12	300	12 x 16	300 x 400	00-0054-0002	1/8	0.06	00-0053-0001
14	350	14 x 16	350 x 400	00-0054-0002	1/8	0.06	00-0053-0001

Replacement Parts

WCK-12 Pigs

WCK-3 Pigs

		Brush Holder			Spring Assembly		
Inches	mm	Wt./Lbs.	Wt./Kg.	Part Number	Wt./Lbs.	Wt./Kg.	Part Number
6	150	1/8	0.06	00-0061-0000	1-1/2	0.68	00-0066-0000
8	200	1/8	0.06	00-0061-0001	1-1/2	0.68	00-0068-0000
10	250	1/8	0.06	00-0061-0002	2-1/4	1.02	00-0070-0000
12	300	1/4	0.11	00-0061-0003	2-1/4	1.02	00-0072-0000
14	350	1/4	0.11	00-0061-0003	2-1/4	1.02	00-0072-0000

		WCK-12DD Pigs			WCK-3DD Pigs		
Inches	mm	Wt./Lbs.	Wt./Kg.	Part Number	Wt./Lbs.	Wt./Kg.	Part Number
6 x 8	150 x 200	1/4	0.11	00-0061-0001	1-1/2	0.68	00-0067-0000
8 x 10	200 x 250	3/4	0.34	00-0161-0000	1-1/2	0.68	00-0068-0000
8 x 12	200 x 300	3/4	0.34	00-0161-0000	1-1/2	0.68	00-0068-0000
10 x 12	250 x 300	1	0.45	00-0165-0000	2-1/4	1.02	00-0070-0000
10 x 14	250 x 350	1	0.45	00-0165-0000	2-1/4	1.02	00-0070-0000
12 x 16	300 x 400	1	0.45	00-0174-0000	2-1/4	1.02	00-0072-0000
14 x 16	350 x 400	1	0.45	00-0174-0000	2-1/4	1.02	00-0072-0000



WCK Cleaning Pigs

WCK-12 Pigs Will Traverse:

- Pipe bends with 6' (1829 mm) radius.
- Miter bends up to 7-1/2° and 1/2" (13 mm) maximum wall thickness. Minimum straight length between miter bends must equal pig length.
- All round, full-opening gate and plug valves. For check valves, consult the factory.
- Tees with full-diameter branch at 90° or 45° to pipeline.
- Guide bars are recommended across opening when branch is 75% of pipe ID.

WCK-3 Pigs Will Traverse:

- 1-1/2 D radius welding ells.
- Miter bends up to 30° and line pipe with 1/2" (13 mm) maximum wall thickness. Six-inch (150 mm) size limited to 45°, 1-1/2 D radius bends; will not pass 90° bends.
- All standard round opening gate and plug valves with a seat ring spacing of 5' 1/4" (133 mm) or less.
- Full-diameter side openings at 90° and 45° to pipeline.

WCK-12DD & WCK-3DD Pigs Will Traverse:

WCK-12DD minimum bend radius

Inches	mm	feet/inches	mm	feet/inches	mm
6 x 8	150 x 200	6' in 6" line	1829 in 150 line	3' in 8" line	914 in 200 line
8 x 10	200 x 250	8' in 8" line	2438 in 200 line	5' in 10" line	1524 in 250 line
8 x 12	200 x 300	8' in 8" line	2438 in 200 line	3' in 12" line	914 in 300 line
10 x 12	250 x 300	8' in 10" line	2438 in 250 line	5' in 14" line	1524 in 300 line
10 x 14	250 x 350	8' in 10" line	2438 in 250 line	4' in 14" line	1219 in 350 line
12 x 16	300 x 400	10' in 12" pipe	3048 in 300 pipe	5' in 16" line	1524 in 400 line
14 x 16	350 x 400	8' in 14" pipe	2438 in 350 pipe	5' in 16" line	1524 in 400 line

WCK-3DD minimum bend radius

6 x 8	150 x 200	24" in 6" line	610 in 150 line	12" in 8" line	305 in 200 line
8 x 10	200 x 250	24" in 8" line	610 in 200 line	15" in 10" line	381 in 250 line
8 x 12	200 x 300	24" in 8" line	610 in 200 line	18" in 12" line	457 in 300 line
10 x 12	250 x 300	30" in 10" line	762 in 250 line	18" in 12" line	457 in 300 line
10 x 14	250 x 350	30" in 10" line	762 in 250 line	21" in 14" line	533 in 350 line
12 x 16	300 x 400	24" in 12" line	610 in 300 line	24" in 16" line	610 in 400 line
14 x 16	350 x 400	21" in 14" pipe	533 in 350 line	24" in 16" line	610 in 400 line

maximum gate valve seat ring spacing
WCK-12 WCK-3

maximum check valve length of bowl
WCK-12DD WCK-3DD

Pig Size		WCK-12		WCK-3		WCK-12DD		WCK-3DD	
Inches	mm	Inches	mm	Inches	mm	Inches	mm	Inches	mm
6 x 8	150 x 200	7-1/2"	191	7-1/2"	191	17	432	8	203
8 x 10	200 x 250	10"	254	8-3/8"	213	22	559	9	229
8 x 12	200 x 300	10"	254	8-3/8"	213	22	559	9	229
10 x 12	250 x 300	10-1/2"	267	9	229	24	610	9	229
10 x 14	250 x 350	10-1/2"	267	8-3/4"	222	24	610	9	229
12 x 16	300 x 400	10-1/2"	267	9-3/4"	248	25	635	9	229
14 x 16	350 x 400	10-1/2"	267	9-3/4"	248	25	635	9	229

WCK Cleaning Pigs

WCK-12 Cleaning Pig

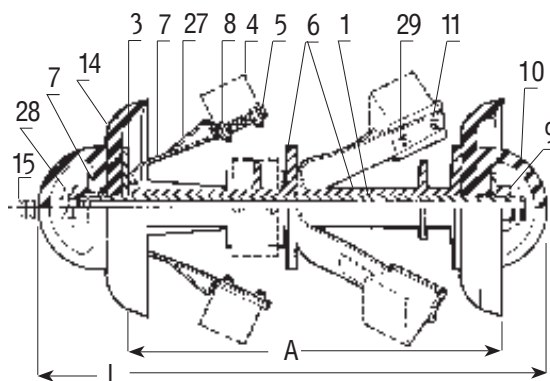

WCK-3 Cleaning Pig

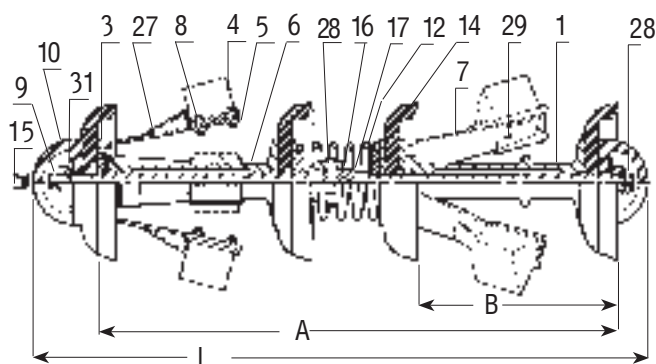

WCK-12DD Cleaning Pig

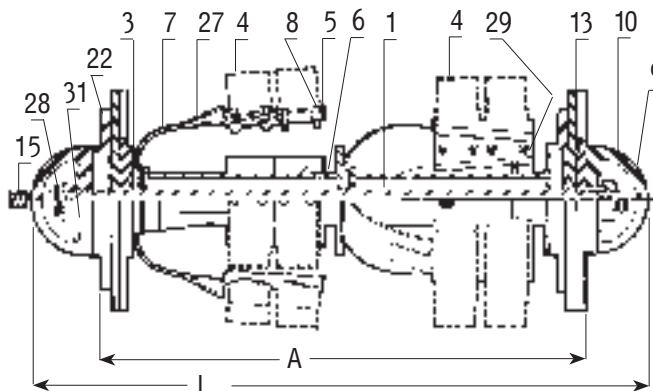

WCK-3DD Cleaning Pig

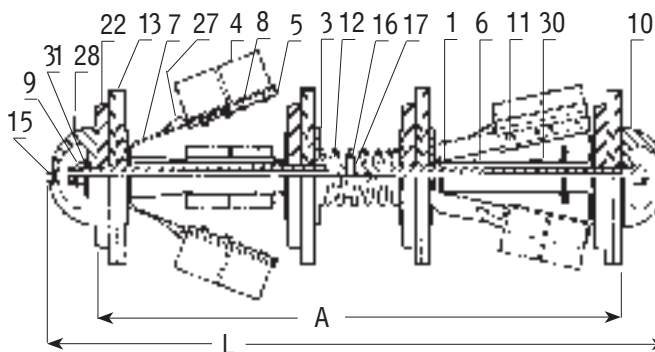



T.D. Williamson

3000.002.04 - p6