



THREAD-O-RING™ Flanged Fitting

Size: 2-inch



T.D. Williamson

Bulletin No: 2100.019.01

Version: 11.2012

Cross Indexing No: n/a

Supersedes: 2100.019.00 (09.2008)



■ THREAD-O-RING™ Flanged Fittings

■ Typical Setup Using THREAD-O-RING™ Flanged Fittings

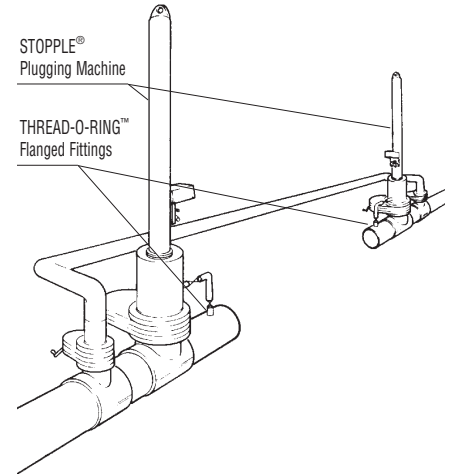

TDW THREAD-O-RING™ Flanged Fittings are used for blowdown of the isolated pipe section following a double STOPPLE® operation.

Description

THREAD-O-RING™ Flanged Fittings are used with TDW Tapping Machines as purge and equalization fittings. They can also be installed during new construction and used for blowdown connections on either side of a block valve.

In addition, the THREAD-O-RING Flanged Fitting will accept the corrosion test coupons, thermometer wells, gauge adapters and other instrument probes.

The THREAD-O-RING Flanged Fitting has a maximum operating pressure per the ANSI Class and Schedule and has a maximum operating temperature of 180°F (82°C).

Features

The complete THREAD-O-RING Flanged Fitting consists of: flange, plug, O-ring, and blind flange kit.

THREAD-O-RING Flanged Fitting taps can be made without shutdown using the TDW T-101 Drilling Machine or the 360 Tapping Machine.

The 2-inch THREAD-O-RING™ Plugs are set using either the T-101 Drilling Machine or the 360 Tapping Machine.

One of the many uses of the THREAD-O-RING Flanged Fitting is as a purge and equalization fitting during tapping operations on pipelines and plant piping.

ISO 9001 Certified

Toll Free

1-888-TDWmSon (839-6766)



THREAD-O-RING™ Flanged Fitting

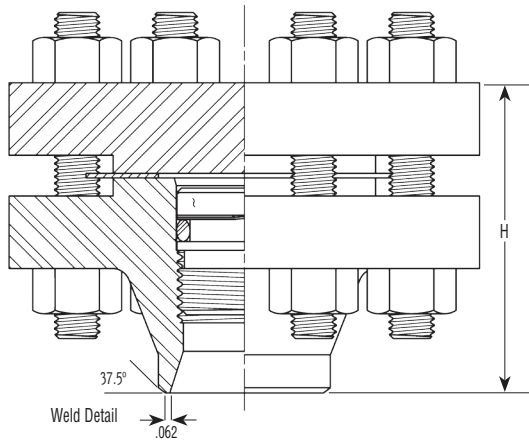

Dimensions

Size		"H" for 6" and larger pipe		Min. Valve I.D.		Weight		Part Number
Inches	mm	Inches	mm	Inches	mm	Lb.	Kg.	
2	50	5-3/16	132	2-1/16	52.4	6-1/2	2.9	See Chart

2" (DN 50) TDW THREAD-O-RING™ Flanged Fitting

FR - NNBB - PMRR - CC

Flange Material

"NN"	Flange Material & Class	Part Number
00	ASTM A105N, 150 LB	00-0465-0001-XX
01	ASTM A105N, 300 LB	00-0465-0002-XX
02	ASTM A105N, 400 & 600 LB	00-0465-0004-XX
03	ASTM A105N, 900 & 1500 LB	00-0465-0005-XX
04	ASTM A350 LF2 CL1, 150 LB	00-8833-0001-XX
05	ASTM A350 LF2 CL1, 300 LB	00-8833-0002-XX
06	ASTM A350 LF2 CL1, 400 & 600 LB	00-8833-0004-XX
07	ASTM A350 LF2 CL1, 900 & 1500 LB	00-8833-0005-XX
08	ASTM A182 F304L STAINLESS, 150 LB	00-8835-0001-XX
09	ASTM A182 F304L STAINLESS, 300 LB	00-8835-0002-XX
10	ASTM A182 F304L STAINLESS, 400 & 600 LB	00-8835-0004-XX
11	ASTM A182 F304L STAINLESS, 900 & 1500 LB	00-8835-0005-XX

Schedule

"BB"	Flange Part Number	Schedule
00	00-XXXX-XXXX -04	10
01	00-XXXX-XXXX -03	40
02	00-XXXX-XXXX -02	80
03	00-XXXX-XXXX -01	160

Maximum Allowable Operating Pressure

Based on Hoop Stress at Weld Hub
Using .72 Design Factor -in psi

Class	Material	Schedule			
		10	40	80	160
150		285	285	285	285
300	ASTM A 105N	740	740	740	740
400	AND	990	990	990	990
600	A350 LF2 CL1	1480	1480	1480	1480
900		2220	2220	2220	2220
1500		2375	3405	3705	3705
150		285	285	285	285
300		740	740	740	740
400	ASTM A182 F304L	990	990	990	990
600		1480	1480	1480	1480
900		1650	2220	2220	2220
1500		1650	2365	3300	3705



THREAD-O-RING™ Flanged Fitting

Blind Flange Kit

"CC"	ANSI Class	Material	Part Number
00	150	ASTM A105N	06-8041-0215-00
01	300	ASTM A105N	06-8041-0230-00
02	400 & 600	ASTM A105N	06-8041-0260-00
03	900 & 1500	ASTM A105N	06-8041-0290-00
04	150	ASTM A-350 LF 2 CL	26-1078-0215
05	300	ASTM A-350 LF 2 CL	26-1078-0230
06	400 & 600	ASTM A-350 LF 2 CL	26-1078-0260
07	900 & 1500	ASTM A-350 LF 2 CL	26-1078-0290
08	150	ASTM 182 F304L ST	26-2223-0215
09	300	ASTM 182 F304L ST	26-2223-0230
10	400 & 600	ASTM 182 F304L ST	26-2223-0260
11	900 & 1500	ASTM 182 F304L ST	26-2223-0290
99	No Blind Flange Kit		

Plug Material

"PM"	Plug Material	Part Number
00	ASTM B-16 Yellow Brass (Std. Mat'l)	00-4172-0100
01	ASTM C1213/1215 CF Stl.	00-4172-0200
02	ASTM 304 CF SST	00-4172-0600
03	ASTM 316 CF SST	00-4172-0400
04	Aluminum, 6061-T6	00-4172-1200
05	ASME SA350 LF2	00-4172-0500
06	ASTM 303 CF SST	00-4172-0300
08	4140 CF Steel	00-4172-0800
12	ASTM A105 Normalized	00-4172-1300
13	ASTM B148 C95400 Al Bronze	00-4172-1400
14	ASTM B21 C46400 Naval Brass	00-4172-1500
15	ASTM 304L SST	00-4172-1600

O-Ring Material

"RR"	O-Ring Material	Part Number
00	No O-Ring	N/A
01	Buna-N (Standard) N674-70	00-0118-0006
02	Viton® V747-75	00-1248-0002
03	Neoprene C1276-70 (Std)	00-1947-0006
04	Ethylene Propylene E540-80 (EPDM)	00-2977-0001
05	Buna-N (Low-Temp) N103-70	00-3079-0001
06	Teflon®	00-1327-0001
07	Neoprene 882-K	00-1808-0003
08	Silicone Rubber	00-3781-0006
09	Neoprene 882-P	00-4677-0006
10	Kalrez®	00-4353-0001
11	Viton® GF	00-6732-0002
12	Teflon® Encapsulated Viton®	00-6762-0002
13	Special Nitrile N-497	00-6932-0001
14	Viton® V1238-95	00-8509-0002

Kalrez® and Viton® are registered trademarks of DuPont Performance Elastomers LLC Ltd.
Teflon® is a registered trademark of E.I. du Pont de Nemours and Company.



T.D. Williamson

2100.019.01- p4