



# SHORTSTOPP® 275/500

## Plugging System, Sizes: 1-1/2- to 12-inch



Bulletin No: 2020.002.04  
Version: 02.2023  
Supersedes: 2020.002.03 (12.2019)



■ **SHORTSTOPP®**  
**Jackscrew Actuator**  
Plugging: 4- to 12-inch

■ **SHORTSTOPP®**  
**Plugging/Completion Machine**  
Plugging: 1- to 4"-inch  
Completion: 1-1/2- to 12-inch

### Description

The lightweight (37 lbs.) SHORTSTOPP® Plugging/Completion Machine is versatile and easy to operate. When used as a plugging machine, it will plug 1-1/2-inch at 275 psi and 2- to 4-inch lines at 500 psi, and can be used on SHORTSTOPP® 300 D Fittings (ASME Class 300). As a completion machine, it has a full range capability of setting 1-1/2- to 12-inch completion plugs, and will adapt to existing housings in the field.

The SHORTSTOPP® Jackscrew Actuator has the capability of plugging 4- to 12-inch lines up to 500 psi. This provides an economical way to plug lines that operate in excess of 275 psi. It also adapts to existing housings in the field, and will plug through SHORTSTOPP® 300 D Fittings (ASME Class 300).

Both models provide an efficient and economical means of stopping off mains for repairs, relocations or additions.

### Specifications

Maximum working pressure is 500 psi (34.5 bar) @ 100°F (38°C). Maximum working temperature is 180°F (82°C) @ 440 psi (30.3 bar). Pressure ratings are limited to fittings and adapters used.



# SHORTSTOPP® 275/500 Plugging System

2020.002 - p2

## Manual SHORTSTOPP® Plugging Machine

Size		Actuator Travel		Overall Length		Weight		Rate of Travel/Revolution		Part Number
Inches	DN	Inches	mm	Inches	mm	Lbs.	Kg.	Inches	mm	
1-1/2 to 4	40 to 100	28	711.2	44-1/2	1130.3	39	18	1/8	3.175	07-1034-0000

## Manual SHORTSTOPP® Completion Machine

Size		Actuator Travel		Overall Length		Weight		Rate of Travel/Revolution		Part Number
Inches	DN	Inches	mm	Inches	mm	Lbs.	Kg.	Inches	mm	
1-1/2 to 12	40 to 300	28	711.2	44-1/2	1130.3	39	18	1/8	3.175	07-1034-0000

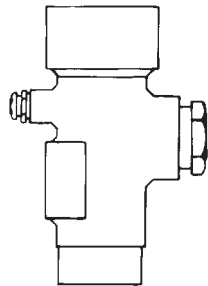

Typical 1-1/2"-3" Housing

### Housings

Size		Weight			
Inches	DN	Part Number	Max. Working Pressure in psi	Lbs.	Kg.
1-1/2	40	08-1746-0000	500	7	3.2
2	50	08-1746-0000	500	7	3.2
3	80	08-1747-0000	500	10	4.5
4	100	08-1748-0000***	275*	28	12.7
4	100	08-2148-0000	500**	36	16.3

\* ASME Class 150  
 \*\* ASME Class 300  
 \*\*\* For use with 07-1034-0000



Typical 1-1/2"-3" Plugging Head

### Plugging Heads

Size		Weight			
Inches	DN	Part Number	Max. Working Pressure in psi	Lbs.	Kg.
1-1/2	40	08-1741-0000	275	1	.5
2	50	08-2252-0000	500	2	1
3	80	08-2253-0000	500	4	1.8
4	100	08-1744-0000	500	9	4

### Sealing Cups Used With 1-1/2- to 4-inch Plugging Machine



Cup

Size		Pipe Dimensions					
Inches	DN	Part Number	Max. Working in psi	Maximum ID		Minimum ID	
				Inches	mm	Inches	mm
1-1/2	40	08-0114-0015	275	1.625	41	1.562	40
2	50	08-0947-0002	275	2.104	53	2.062	52
2	50	08-3425-0002	500	2.104	53	2.062	52
3	80	08-0947-0003	275	3.187	81	3.062	78
3	80	08-2253-0005	500	3.187	81	3.062	78
4	100	08-0947-0004	275	4.25	108	4.015	102
4	100	08-0036-0005	500	Specify pipe ID when ordering.			



# SHORTSTOPP® 275/500 Plugging System

## Manual SHORTSTOPP® Jackscrew Actuator

Size		Actuator Travel		Overall Length		Weight		Rate of Travel/Revolution		Part Number
Inches	DN	Inches	mm	Inches	mm	Lbs.	Kg.	Inches	mm	
4 to 12	100 to 300	48	1219	64-1/8	1629	140	64	1/8	3	08-0940-0000

## Plugging Housings\*

Size		Class 150			Weight		Class 300			Weight	
Inches	DN	Part Number	Max. Working Pressure in psi	Lbs.	Kg.	Part Number	Max. Working Pressure in psi	Lbs.	Kg.		
4	100	08-0941-0000	275	48	22	08-2143-0000	500	51	23		
6	150	08-0942-0000	275	75	34	08-2144-0000	500	81	37		
8	200	08-0943-0000	275	96	43	08-2145-0000	500	141	64		
10	250	08-0944-0000	275	156	71	08-2146-0000	500	207	94		
12	300	08-0945-0000	275	221	100	08-2147-0000	500	297	135		

\*4- to 12-inch plugging machine housings also can function as completion housings to set 4- to 12-inch completion plugs with use of an 06-7264-0000 adapter plate.

## Plugging Heads

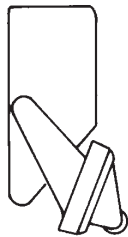

Typical 6" Plugging Head

Size		Class 150			Weight	
Inches	DN	Part Number	Max. Working Pressure in psi	Lbs.	Kg.	
4	100	08-1630-0000	500	7	3	
6	150	08-1908-0000	500	24	11	
8	200	08-1909-0000	500	44	20	
10	250	08-1910-0000	500	88	40	
12	300	08-1911-0000	500	150	68	

## Sealing Cups Used With 4- to 12-inch Plugging Machine



Cup

Size		Class 150			Pipe Dimensions			
Inches	DN	Part Number	Max. Working in psi	Maximum ID	Minimum ID			
				Inches	mm	Inches	mm	
4	100	08-0947-0004	275	4.25	108	4.015	102	
4	100	08-0036-0005	500	Specify pipe ID when ordering.				
6	150	08-0947-0006	275	6.125	156	6.062	154	
6	150	08-0948-0006	275	6.312	160	6.187	157	
6	150	08-0040-0005	500	Specify pipe ID when ordering.				
8	200	08-0947-0008	275	8	203.2	7.968	202.7	
8	200	08-0948-0008	275	8.343	212	8.062	205	
8	200	08-0246-0005	500	Specify pipe ID when ordering.				
10	250	08-0947-0010	275	10.125	257	10.015	254	
10	250	08-0948-0010	275	10.375	264	10.187	259	
10	250	08-0247-0005	500	Specify pipe ID when ordering.				
12	300	08-0947-0012	275	12.343	314	11.937	303	
12	300	08-0248-0005	500	Specify pipe ID when ordering.				



# SHORTSTOPP® 275/500 Plugging System

## SHORTSTOPP® Plugging/Completion Machine — Part Number 07-1034-0000

For 1-1/2- to 4-inch sizes, the actuator functions as a plugging machine. This same actuator also functions as a completion machine for sizes 1-1/2- to 12-inch. In sizes 1-1/2- to 4-inch, the plugging housings also serve as completion machine housings, without need for adapter plates (see page 2).

## Housings and Adapters

When used with the proper adapter plate, these plugging housings and T-203 adapters can be used with the plugging/completion machine to set 4- to 12-inch plugs.

### 1-1/2- to 12-inch Completion Plug Holders

Size			Weight	
Inches	DN	Part Number	Lbs.	Kg.
1-1/2 - 3	40 - 80	07-0974-0000	1	.5
4 - 8	100 - 200	07-0334-0000	2	1
10 - 12	250 - 300	07-0335-0000	2-1/2	1.5

NOTE: Completion plug setting pressure limited to pressure rating of completion machine.

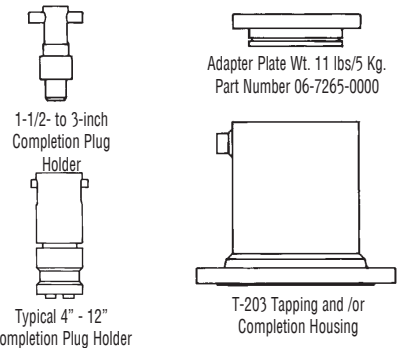

Adapter plate only needed when used with the plugging/completion machine (07-1034-0000) on 4- to 12-inch T-203 Tapping Machine Adapters.

### T-203 Tapping Machine Adapters\*

Size			Class 150	Weight		Class 300	Weight		
Inches	DN	Part Number	Max. Working in psi	Lbs.	Kg.	Part Number	Max. Working in psi	Lbs.	Kg.
4	100	06-1542-0000	275	29	13	06-7370-0000	720	38	17
6	150	06-1543-0000	275	43	20	06-7371-0000	720	65	30
8	200	06-1544-0000	275	67	30	06-7372-0000	720	95	43
10	250	06-1545-0000	275	95	43	06-7373-0000	720	140	64
12	300	06-1546-0000	275	160	73	06-7374-0000	720	205	93

\*T-203 Tapping Machine adapters also function as completion housings to set 4- to 12-inch completion plugs with use of an 06-7265-0000 adapter plate.

## Side Outlet Pluggers — Maximum Working Pressure is 275 psi

### 1-1/2- to 4-inch using Plugging/Completion Machine

Size		Part Number	Weight		Spare Seals
Inches	DN		Lbs.	Kg.	Part Number
1-1/2	40	08-1871-0000	1.5	.7	08-1871-0002
2	50	08-1872-0000	2.2	1	08-0976-0002
3	80	08-1873-0000	5	2	08-0977-0002
4	100	08-1874-0000	12	5	08-0928-0002

### 4- to 12-inch using Jackscrew Actuator

4	100	08-0928-0000	12	5	08-0928-0002
6	150	08-0929-0000	24	11	08-0929-0002
8	200	08-0930-0000	38	17	08-0930-0002
10	300	08-0931-0000	67	30	08-0931-0002
12	350	08-0932-0000	95	43	08-0932-0002

## Side Outlet Plugging Option

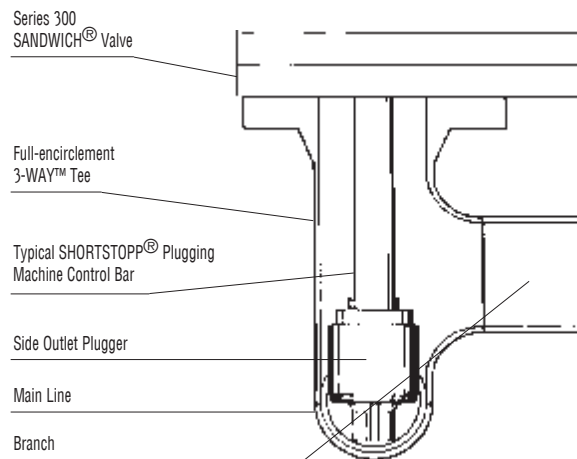

The side outlet plunger can be installed on the end of either SHORTSTOPP Plugging Machine and is used on TDW 3-WAY Tees™ and Spherical 3-WAY Tees™ to plug the tapped hole in the main line. This stops flow into the side outlet, permitting maintenance work on the branch connection.